



T&S BRASS AND BRONZE WORKS, INC.

2 Saddleback Cove / P.O. Box 1088
Travelers Rest, SC 29690

Model No.

B-1025-1

Item No.

Travelers Rest, SC: 800-476-4103 • Simi Valley, CA: 800-423-0150 • Fax: 864-834-3518 • www.tsbrass.com

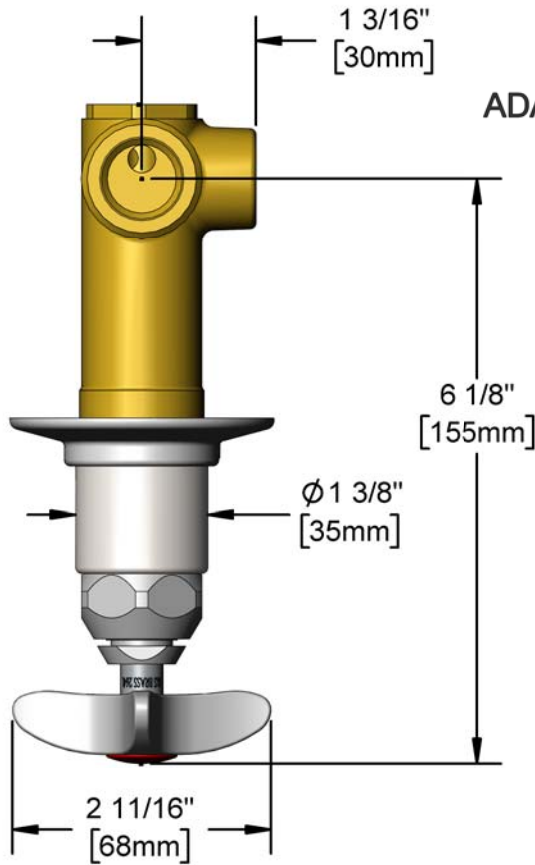

ADA Compliant

This Space for Architect/Engineer Approval

Job Name _____ Date _____

Model Specified _____ Quantity _____

Customer/Wholesaler _____

Contractor _____

Architect/Engineer _____

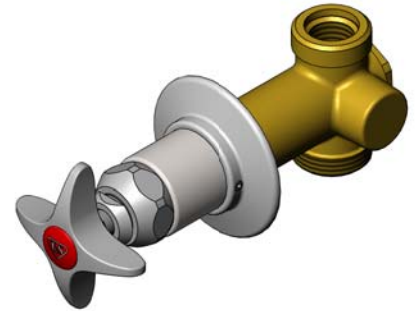

Quarter-Turn Eterna Cartridge w/ Spring Check & 4-Arm Handle w/ Red (HW) Color Coded Index

Ø 2 3/4" [70mm] Adjustable Flange w/ Set Screw

1/2" NPT Female Outlet

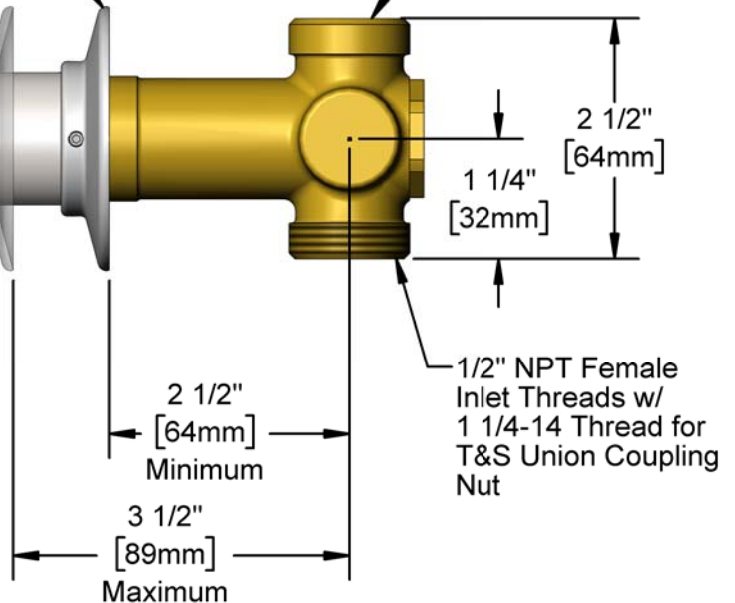

Rough-In Requirement:
Ø 1 1/2" [38mm] Mounting Hole

Product Specifications:

Concealed Straight Valve, Quarter-Turn Eterna Cartridge w/ Spring Check, 4-Arm Handle w/ Red (HW) Color Coded Index & 1/2" NPT Inlet & Outlet

Product Compliance:

ASME A112.18.1 / CSA B125.1
NSF 61 - Section 9
NSF 372 (Low Lead Content)
ANSI A117.1 (ADA)



T&S BRASS AND BRONZE WORKS, INC.

2 Saddleback Cove / P.O. Box 1088
Travelers Rest, SC 29690

Model No.

B-1025-1

Item No.

Travelers Rest, SC: 800-476-4103 • Simi Valley, CA: 800-423-0150 • Fax: 864-834-3518 • www.tsbrass.com

ITEM NO.	SALES NO.	DESCRIPTION
1	001193-19NS	Red Button Index, Press-in
2	000925-45	Lab Handle Screw
3	002521-45NS	4-Arm Handle (New Style)
4	012443-40NS	Quarter-Turn Eterna Cartridge w/ Spring Check, RTC
5	001501-40	Escutcheon
6	151F	Escutcheon Tube
7	001702-45	O-Ring
8	001062-45	O-Ring
9	000939-45	Escutcheon, Set Screw

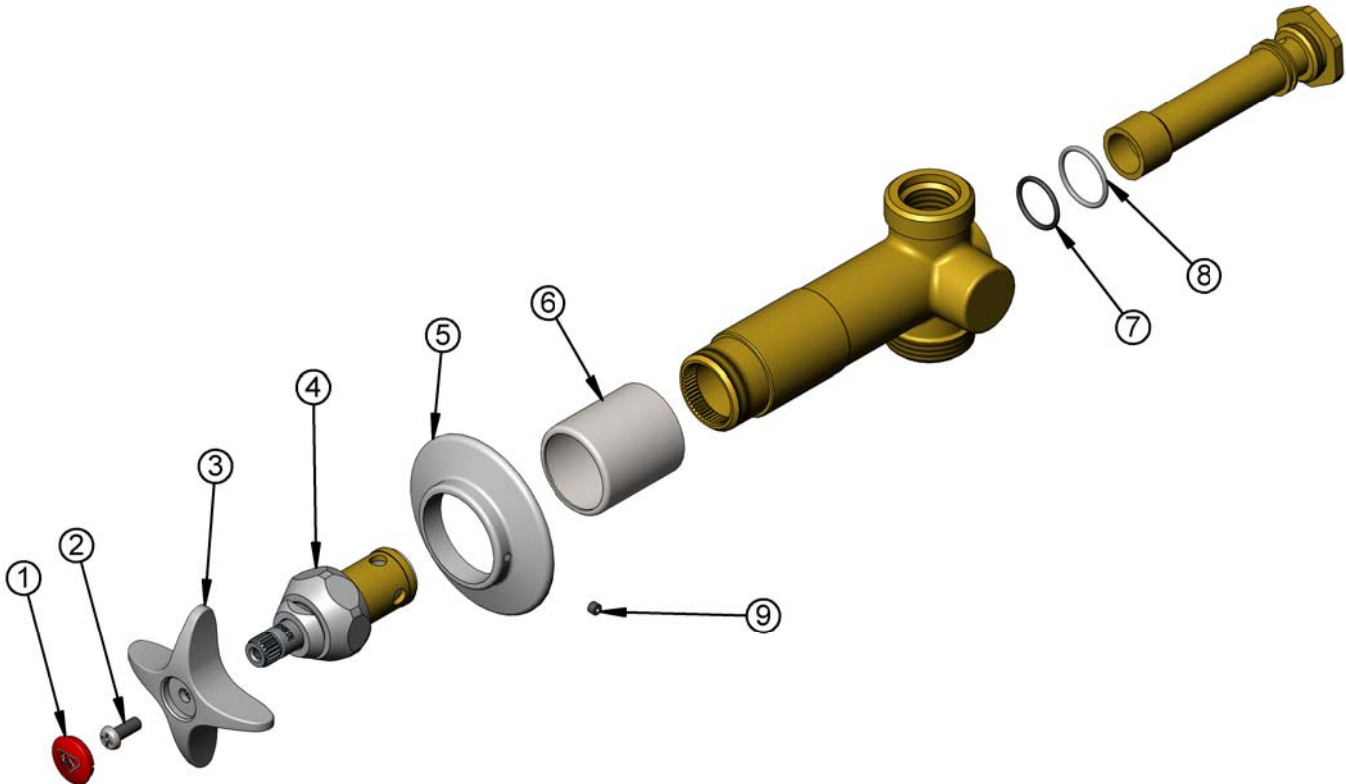

Product Specifications:

Concealed Straight Valve, Quarter-Turn Eterna Cartridge w/ Spring Check, 4-Arm Handle w/ Red (HW) Color Coded Index & 1/2" NPT Inlet & Outlet

Product Compliance:

ASME A112.18.1 / CSA B125.1
NSF 61 - Section 9
NSF 372 (Low Lead Content)
ANSI A117.1 (ADA)