

SENSOR-OPERATED, DECK-MOUNT FOAM SOAP DISPENSER

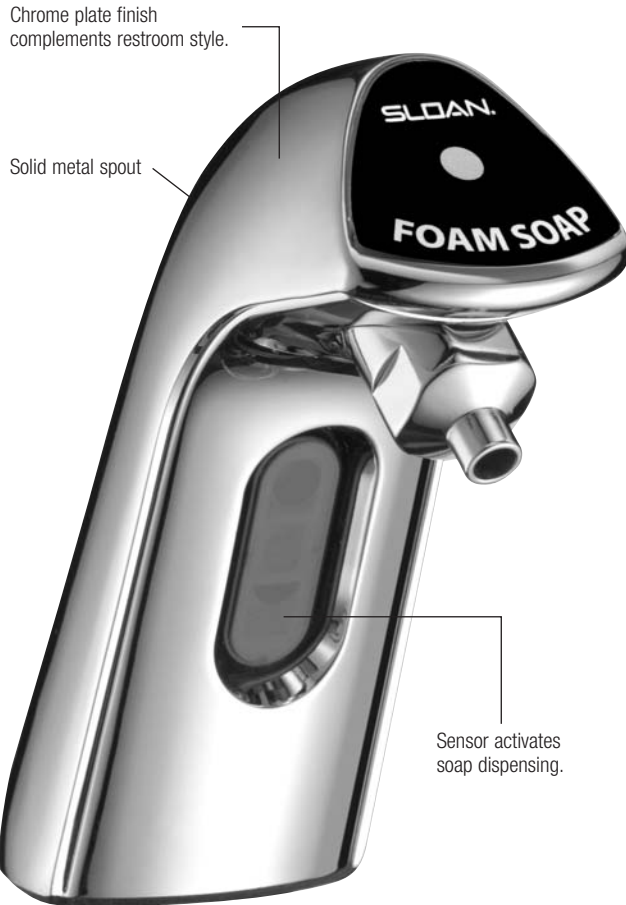

The SJS-1750 sensor-operated foam soap dispenser is the next evolution in dispenser technology. It uses a refill bottle that simplifies replacement and reduces waste. Its sensor technology offers hands-free operation by delivering a pre-measured foam soap application "on demand."

- Sensor-technology activates foam soap dispensing
- Hand-free operation promotes hygiene and eliminates cross contamination
- Easily attaches to deck surface
- Low soap level indicator
- 110 VAC

The contemporary design complements all restrooms.

Product Number: SJS-1750
Product Code: 700015
Color: Chrome
Size: W 1.65" x D 4.25" x H 4.00"
 (W 42 mm x D 108 mm x H 102 mm)

Quantity/pack: 1
Quantity/case: 6

Refills:

Product No.	Description	Order No.
SJS-1751	Sensor Deck-Mount Foam Soap	0700751
SJS-1751-1	Sensor Deck-Mount Foam Soap with Moisturizers	0700752
SJS-1751-2	Sensor Deck-Mount Antimicrobial Foam Soap	0700753
SJS-1751-3	Sensor Deck-Mount Foam Soap Green Seal (Fragrance Free)	0700754
SJS-1751-4	Sensor Deck-Mount Foam Soap Green Seal (Rose)	0700755

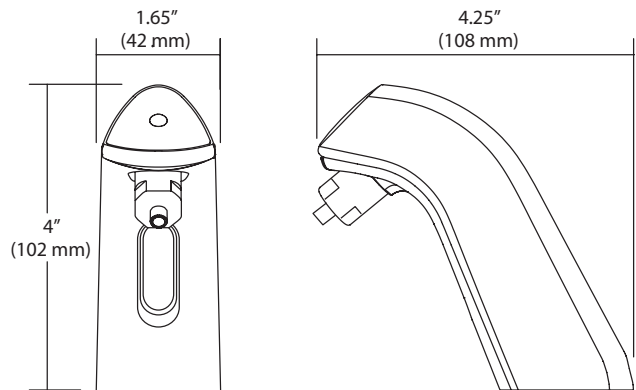
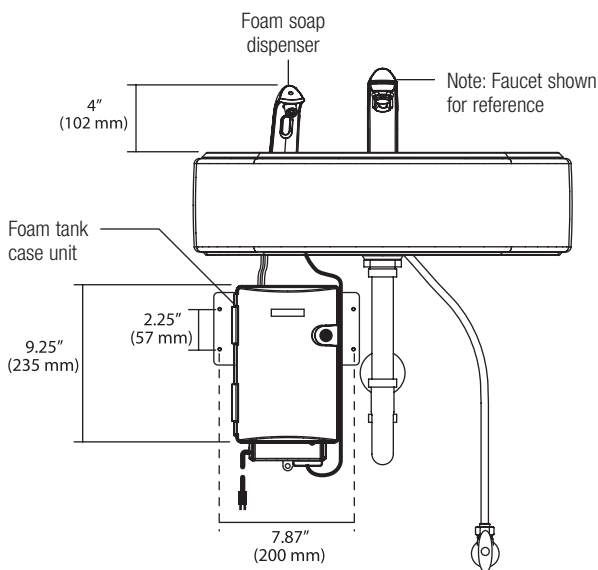

The information contained in this document is subject to change without notice.

SLOAN®

Air Delights, Inc.
 9974 SW Arctic Dr.
 Beaverton, Or. 97005
 Phone: 800-440-5556
 Fax: 503-643-8224
 www.airdelights.com