

Optima® EBF-615/EBF-650

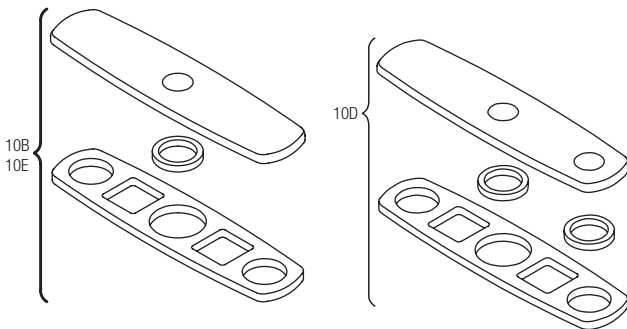
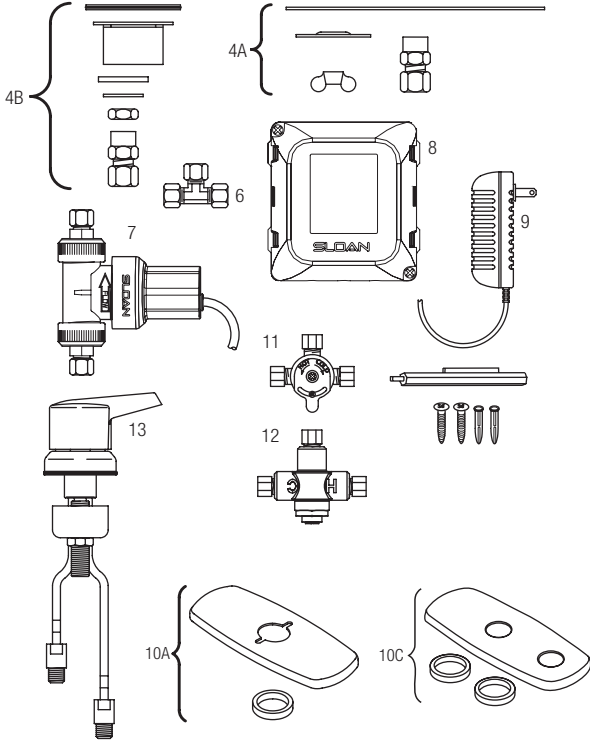
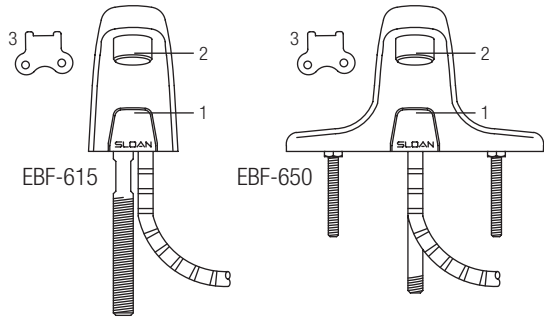
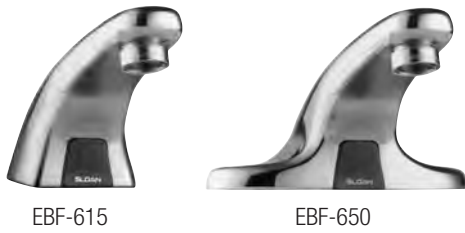

PARTS LIST—EBF-615 AND EBF-650 FAUCETS

Item No.	Code No.	Part No.	Description
1.	0365400	ETF-749-A	Sensor Only
2.	3365092	ETF-1023-A	0.5 gpm (1.9 Lpm) Spray Head with Key (male thread)
	3365093	ETF-1024-A	2.2 gpm (8.3 Lpm) Aerator Spray Head with Key (male thread)
	3365162	ETF-1029-A	2.2 gpm (8.3 Lpm) Laminar Flow (male thread)
	3365756	ETF-1039-A	0.35 gpm (1.3 Lpm) Multi-Lam Spray Head VR
3.	0305927	ETF-435	Replacement Key Only for ETF-1023-A 0.5 gpm (1.9 Lpm) Spray Head and ETF-1024-A 2.2 gpm (8.3 Lpm) Aerator Spray Head
4A.	3365088	ETF-546-A	Faucet Mounting Kit for EBF-650 includes Base Gasket, two (2) Slotted Mounting Washers, two (2) Wing Nuts and ETF-547 Compression Fitting Connector
4B.	0315085	EBF-123-A	Faucet Mounting Kit for EBF-615 includes Base Gasket, Spacer, Washer, 9/16" Lockwasher, 1/4" NPSM Hex Nut and ETF-547 Compression Fitting Connector
5.	0365058	ETF-547	1/8" NPT Pipe to 3/8" Tube Compression Fitting Connector (female)
6.	3365461	ETF-617-A	3/8" Bak-Chek® Tee Compression Fitting
7.	0365758	ETF-740-A	6 VDC Solenoid Valve Assembly
7A.	0365774	ETF-742-A	Solenoid with armored cable and wire only (no valve assembly)
8.	0365752	ETF-735-A	Control Module
9.	0362006	SFP-6	110 VAC/6 VDC Plug-In Adapter
—	0365838	ETF-1003	36" Extension Cable (Optional)

OPTIONAL TRIM PLATES

10A.	3365302	ETF-607-A	4" (102 mm) Centerset Trim plate for EBF-625
10B.	3365303	ETF-608-A	8" (204 mm) Centerset Trim Plate for EBF-625
10C.	3326012	MIX-101-A	4" (102 mm) Centerset Trim plate for EBF-625 with optional mixing Valve
10D.	3326017	MIX-106-A	8" (204 mm) Centerset Trim plate for EBF-625
10E.	3365119	ETF-578-A	8" (204 mm) Centerset Trim plate for EBF-655

OPTIONAL MIXING VALVES

11.	3326009	MIX-60-A	Below Deck Mechanical Water Mixing Valve (BDM Variation)
12.	0326045	MIX-135-A	Below Deck Thermostatic Water Mixing Valve (BDT Variation)
13.	3326018	MIX-110-AA	Optimix® Deck Mounted Water Mixing Valve (only available for EBF-615 faucets)

— Not shown in illustration

For parts prior to September 2008 (Old Style) refer to page 182 (EBF-625 & EBF-655).

Optima® EBF-615/EBF-650

TROUBLESHOOTING GUIDE

1. Sensor LED DOES NOT function (sensor indicator light does not flash during initial 10 minute set-up mode).

A. There is no visible indicator light. Normal operation. This is a normal operating feature of the faucet.

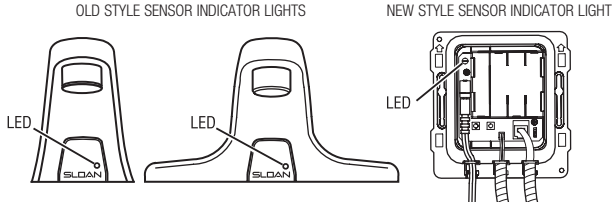

2. Faucet DOES NOT deliver any water when Sensor is activated.

INDICATOR: Solenoid valve produces audible “CLICK.”

A. Water supply stop(s) closed. Open supply stop(s) completely.

INDICATOR: Solenoid valve DOES NOT produce an audible “CLICK.”

- B. Solenoid lead is not properly connected to the control module. Disconnect and reconnect solenoid Lead to the control module.
- C. No battery or adapter (optional) power is being supplied to sensor. Ensure that the batteries are installed properly. Check that the orientation of each battery matches the positive (+) and negative (−) symbols shown on the bottom of the battery compartment. Reinsert the batteries into the control module. Adapter (optional) is unplugged or wall receptacle has no power.

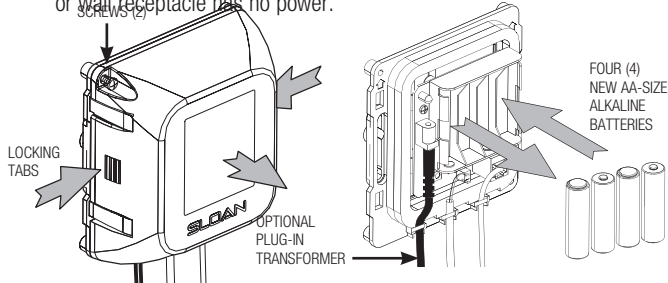

- D. Sensor cable is not properly connected to the control module. Disconnect and reconnect sensor cable to the control module.
- E. Sensor range is set at minimum distance. Increase sensor range. Refer to Step 9, Range adjustment in your installation instructions.
- F. Control module assembly is not working properly. Replace control module assembly.

3. Faucet delivers only a slow flow or dribble when sensor is activated.

- A. Water supply stop(s) partially closed. Open supply stop(s) completely.
- B. Solenoid filter is clogged. Remove, clean and reinstall filter. Turn off water supply at supply stop(s). Activate faucet to relieve system pressure. Remove water supply line from inlet side of solenoid valve. Remove cap, water line fitting, gasket, filter housing and filter from solenoid valve housing. Slide filter off filter housing. Clean filter using fresh tap water only. If necessary, use a small brush to clean. Use caution while cleaning to prevent damage to filter. If any filter components are damaged, replace as necessary. Examine the gasket for wear or damage; replace if necessary. Reinstall filter on filter housing. Install filter housing, gasket, water line fitting and cap onto solenoid valve housing. Tighten cap securely. Reinstall water supply line to inlet side of solenoid valve.

C. Aerator is clogged. Remove, clean and reinstall aerator.

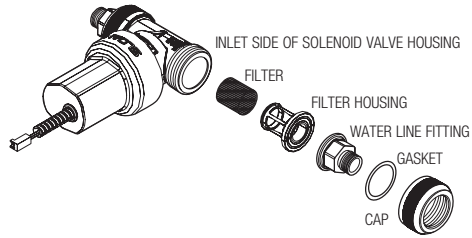

4. Faucet DOES NOT stop delivering water or continues to drip after user is no longer detected (automatic shut-off fails even when batteries are removed).

- A. Solenoid valve has been connected backwards. Disconnect solenoid valve compression fittings at both the inlet and outlet positions. The water should flow from inlet through the solenoid valve to the outlet according to the direction of the arrow shown on the side of the solenoid valve. Reconnect the compression fittings in the correct orientation.
- B. Solenoid valve is dirty. Backflush by reversing water flow (opposite to the direction shown by the arrow on the side of the solenoid valve) through the solenoid valve. Reconnect the compression fittings in the correct orientation. Activate faucet.
- C. Solenoid valve module is not working properly. Replace solenoid valve module.

5. The water temperature is too hot or too cold on a faucet connected to hot and cold supply lines with Bak-Chek Tee.

A. Supply stops are not adjusted properly. Adjust supply stops.

NOTE: For some systems, a thermostatic mixing valve may be required.

6. The RED LED turns on in the control module (below deck).

- A. One (or more) of the batteries is “dead”. To ensure proper operation, insert four (4) new AA-size Alkaline batteries. Check that the orientation of each battery matches the positive (+) and negative (−) symbols shown on the bottom of the battery compartment. Reinsert batteries into the control module.
- B. Upon start-up mode the control module circuitry also tests the batteries and the RED LED turns on if the battery voltage is low, no RED LED light indicates normal battery voltage.
- C. If reset (initiates start up mode) button is pressed, the battery voltage is checked. If voltage is too low, product is stopped from operating and RED LED will turn on. No RED LED light indicates normal battery voltage.

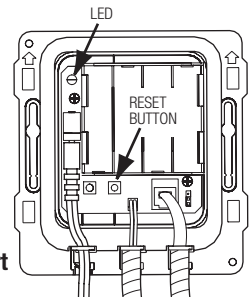

7. The GREEN LED initially turns on in the control module (below deck) during start up mode, then will not appear again.

INDICATOR: For the 1st ten minutes of operation (batteries inserted or reset button pressed) the GREEN LED will turn on when there is a target present (hands in front of sensor). After ten minutes, the GREEN LED will no longer turn on.

A. This is a normal operating feature of the faucet.