

CODE NUMBER

3335193

DESCRIPTION

Hardwired Less Transformer Power Supply, Mixer Not Included, Polished Chrome Finish, 0.35 gpm, Multi-Laminar Spray, Infrared Sensor, Optima® Hardwired-Powered Deck-Mounted Mid Body.

DETAILS

- Flow Rate: 0.35 gpm (1.3 Lpm) (0.35GPM)
- Spray Type: Multi-Laminar (MLM)
- Sensor Type: Infrared (IR)
- Mounting Type: Single Hole ()
- Power Supply: Hardwired Less Transformer (HLT)
- Temperature Mixer: Mixer Not Included ()
- Finish: Polished Chrome (CP)
- Factory Default Timeout: 30s
- Factory Default GPC: 0.175

FEATURES

Commercial Grade, ADA Compliant, Electronic, Sensor-Activated, Cast Brass Hand Washing Faucet with the following features:

- Double Infrared Sensors with Automatic Setup and Indicator Light
- Automatic Self-adapting Sensor Technology
- Magnetic Solenoid Valve
- Water Supply Connection with Flexible High-pressure Hose and Strainer
- 6 Volt DC Plug-in Adapter (must be ordered separately for Less transformer (-LT) faucets)
- Daisy Chain Electrical Splitter Cable included with Less transformer (-LT) faucets
- Appropriate Mounting Hardware included
- Optional 24 Hour Sentinel Activation
- IQ-Click feature permits activation of continuous run and temporary off modes

ELECTRICAL SPECIFICATIONS

- Sensor Range: 4"-5" (102-127mm)
- Timeout Adjustment Settings: 30s

VIDEOS

- ▶ Sloan Connect App®

DOWNLOADS

- [EAF 100/150 Installation Instructions](#)
- [EAF 100/150 \(SP\) Installation Instructions](#)
- [Optima Plus EAF 100 Repair and Maintenance Guide](#)
- [Faucet Spray Heads Repair and Maintenance Guide](#)
- [Trim Plate Guide](#)
- [Additional Downloads](#)

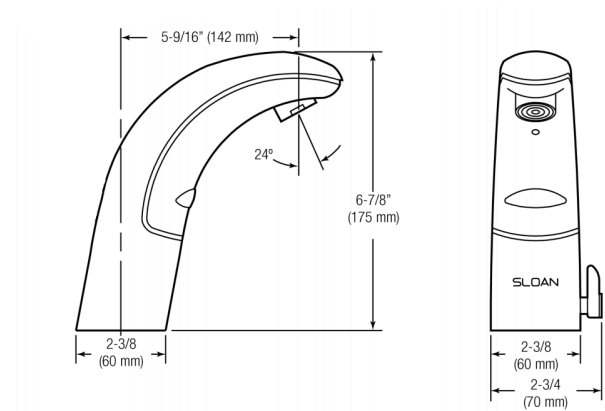

COMPLIANCES & CERTIFICATIONS



(ADA Compliant, ASME A112.18.1 Compliant, BREEAM Water Credit, CalGreen Compliant, CEC Compliant, cUPC Certified, UPC Certified, UPC Low Lead Compliant, cUPC Low Lead Compliant, EPD, Green Globes Water Credit, HPD, LEED V4 Water Efficiency Credit, NYC604.4, Proposition 65, Satisfies LEED Credits, TAS, WELL Building Standard)

NOTES

All information contained within this document subject to change without notice.

Looking for other variations of the EAF-100 product? [View the general spec sheet with all options.](#)

[Find a matching soap dispenser](#) for this faucet.

[Find a compatible sink](#) for this faucet.

Sloan 10500 Seymour Ave, Franklin Park, IL 60131

Phone: 800.982.5839 • Fax: 800.447.8329 • sloan.com

WARRANTY

3 Year

ROUGH-IN

EAF-100, EAF-100-LT, EAF-100-P,
 EAF-100-P-IC, AND EAF-100-LT-IC
 Faucets with Single Line Water Supply

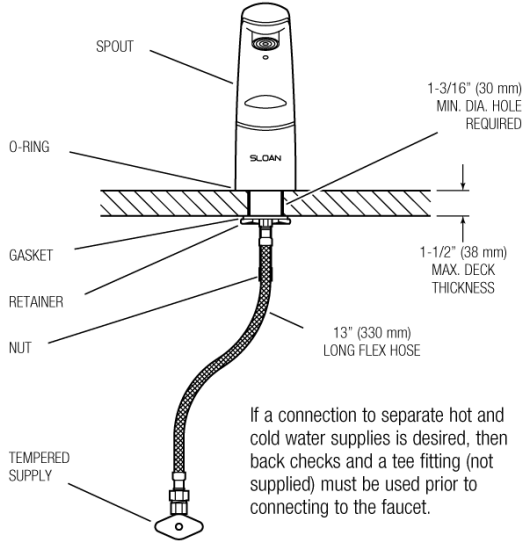

EAF-100-ISM, EAF-100-ISM-IC AND
 EAF-100-ISM-DPU-IC
 Faucets with Hot and Cold Water Supply

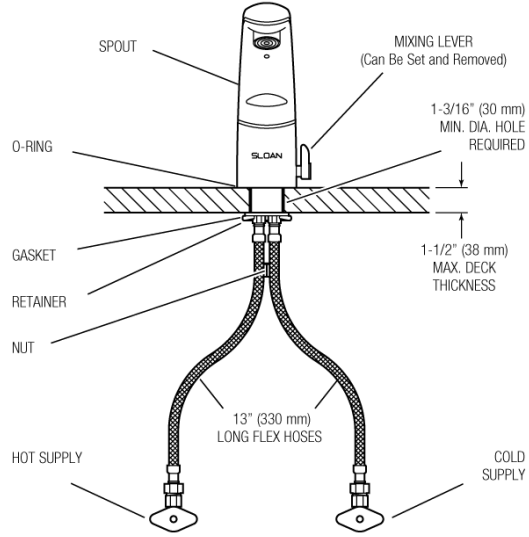

When the EAF faucet is installed on a sink that has three (3) hole punchings, a Trim Plate should be used. Trim Plates must be specified and ordered separately:

- SFP-11 Trim Plate for 4" (102 mm) Centerset Sink
- SFP-22 Trim Plate for 8" (204 mm) Centerset Sink