

► **Code Number**

3250295

► **Description**

- Exposed, Battery Powered, Sensor Operated G2® Model Water Closet Flushometer for floor mounted or wall hung top spud bowls.

► **Flush Cycle**

- 1.28 gpf/4.8 Lpf

► **SPECIFICATION**

Specifications

Quiet, Exposed, Diaphragm Type, Closet Flushometer for either left or right hand supply with the following features:

- Handle Packing, Main Seat, Stop Seat and Vacuum Breaker Molded from PERMEX® Rubber Compound for Chloramine resistance
- PERMEX® Synthetic Rubber Diaphragm with Dual Filtered Fixed Bypass
- Sweat Solder Adapter with Cover Tube and Cast Set Screw Wall Flange
- Initial Set-up Range Indicator Light (first 10 minutes)
- User friendly three (3) second Flush Delay
- "Low Battery" Flashing LED
- Infrared Sensor with Multiple-focused, Lobular Sensing Fields for high and low target detection
- Latching Solenoid Operator
- Fixed Metering Bypass and No External Volume Adjustment to Ensure Water Conservation
- Flex Tube Diaphragm designed for improved life and reduced maintenance
- Engineered Metal Cover with replaceable Lens Window
- Four (4) Size AA alkaline Batteries included: Duracell® with DURALOCK Power Preserve Technology™-guaranteed for up to 10 years in storage
- ADA Compliant Battery Powered Infrared Sensor for automatic "Hands-free" operation
- Courtesy Flush® Override Button
- Flush accuracy controlled by CID® technology
- Spud Coupling and Flange for 1 1/2" Top Spud
- 1" I.P.S. Screwdriver Bak-Chek® Angle Stop with Free Spinning Vandal Resistant Stop Cap

Valve Body, Cover, Tailpiece and Control Stop shall be in conformance with ASTM Alloy Classification for Semi-Red Brass. Valve shall be in compliance with the applicable sections of ASSE 1037 and ANSI/ASME 112.19.2.

Designed for

- The Model 8115 valve is designed for installations where the water supply is roughed-in 24" (610 mm) above the top of the water closet. While the Model 8115 no longer requires the use of a Beam Deflector, for new installations Sloan still recommends the use of the Model 8111 valve which has a shorter installation height."

► **ELECTRICAL SPECIFICATION**

Control Circuit

- Solid State
- 6 VDC Input

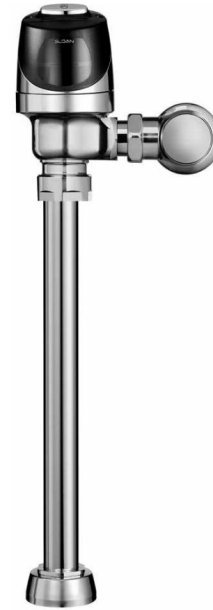

► **FEATURES**

Automatic Operation

- Sloan G2 Optima Plus Flushometers activate via multi-lobular sensor detection to provide the ultimate in sanitary protection and automatic operation. A battery powered infrared sensor sets the flushing mechanism after the user is detected and completes the flush when the user steps away.

Functional & Hygienic

- Touchless, sensor operation eliminates the need for user contact to help control the spread of infectious diseases. The Optima Plus® Flushometer is provided with an Override Button to allow a "courtesy flush" for individual user comfort.

Economical

- Sloan installed batteries speed installation and provide years of metered flushing to control the use of water and energy. Batteries can be changed without turning off the water.

► **Compliance & Certifications**



This space for Architect/Engineer Approval

- 8 Second Arming Delay
- 3 Second Flush Delay

Optional Sentinel Flush

- Once Every 72 Hours After the Last Flush. Product shipped from factory with feature turned off. Consult factory to activate.

Sensor Type

- Active Infrared

Sensor Range

- Nominal 22" - 42" (559 mm - 1067 mm) Self-adaptive Window: ± 10" (254 mm)

Battery Type

- (4) AA Lithium

Battery Life

- 6 Years @ 4,000 flushes/month

Indicator Lights

- Range Adjustment

Operating Pressure

- 15 - 100 psi (104 - 689 kPa)

► ROUGH-IN

When installing the G2 Optima Plus in a handicap stall: Per the ADA Guidelines (section 604.9.4) it is recommended that the grab bars be split or shifted to the wide side of the stall.

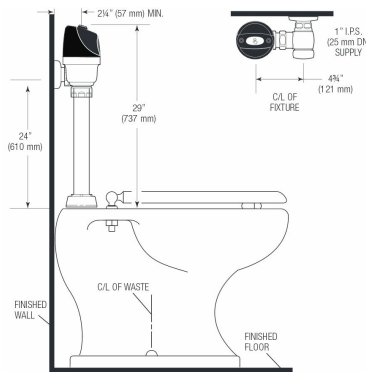

For new installations, Sloan strongly recommends the use of our Model 8111 which has a shorter installation height.

► OPERATION



1. A continuous, invisible light beam is emitted from the OPTIMA Plus Sensor.

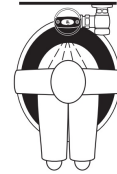

2. As the user enters the beam's effective range (22" to 42") the beam is reflected into the OPTIMA Plus Scanner Window and transformed into a low voltage electrical circuit.

Once activated, the Output Circuit continues in a "hold" mode for as long as the user remains within the effective range of the Sensor.



3. When the user steps away from the OPTIMA Plus® Sensor, the circuit waits 3 seconds (to prevent false flushing) then initiates an electrical signal that operates the Solenoid. This initiates the flushing cycle to flush the fixture. The Circuit then automatically resets and is ready for the next user.

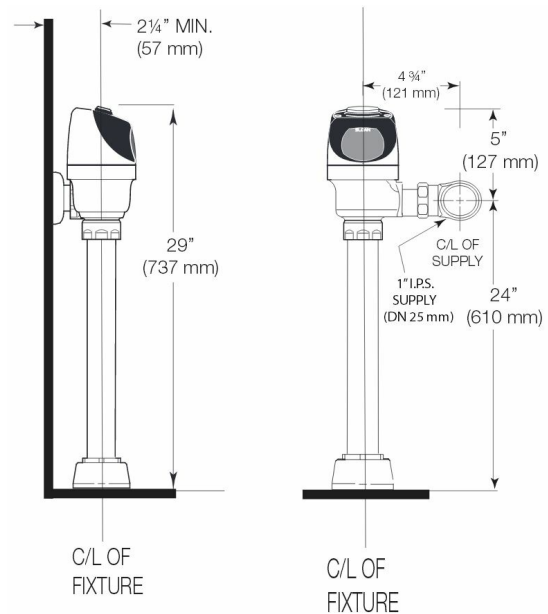

► Disclaimer

- All information contained within this document subject to change without notice.