

**5170, 5171, 5172, 5173, 5174, 5178
(STRIKE - INSWING/OUTSWING FLAT)**

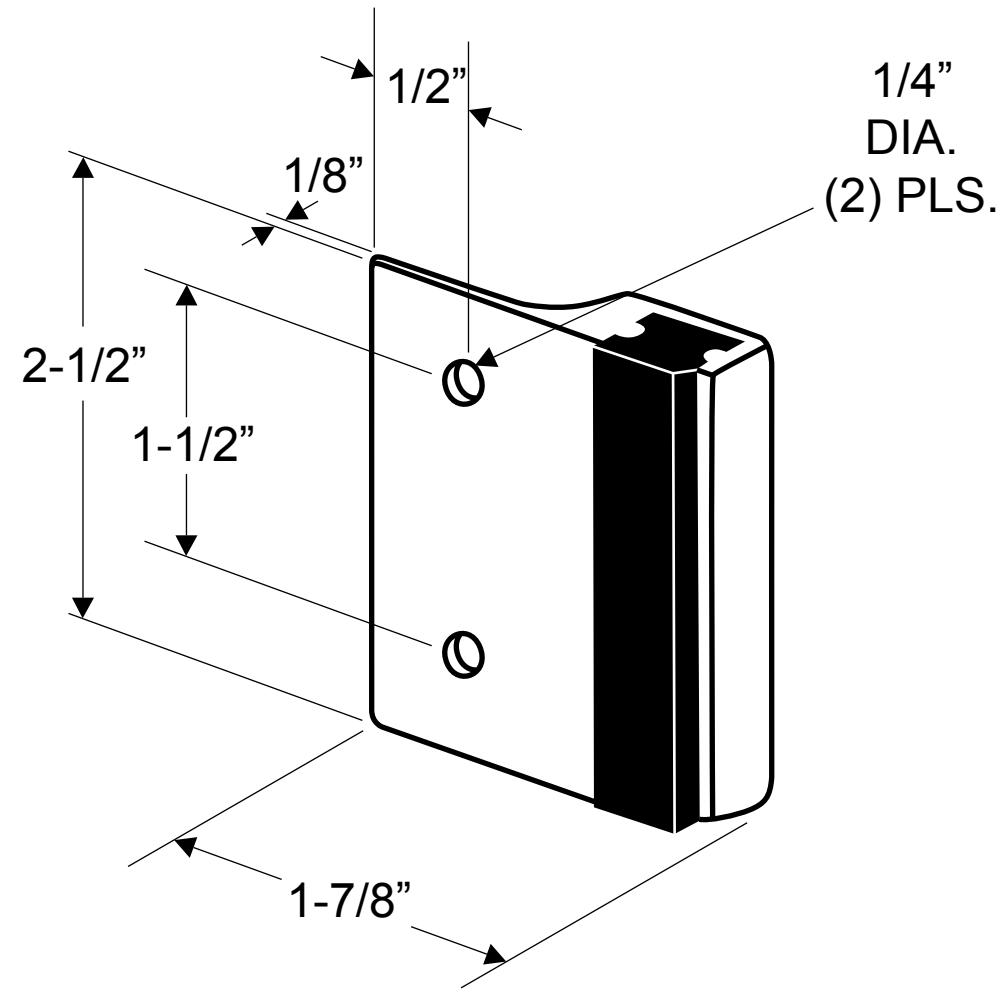

NOTE: FOR SQUARE EDGE POST

**INSTRUCTIONS FOR INSTALLING
5160, 5170, 5180 STRIKE & KEEPER
WITH 5020, 5030 SLIDE LATCH**

**OUTSWING
APPLICATION**

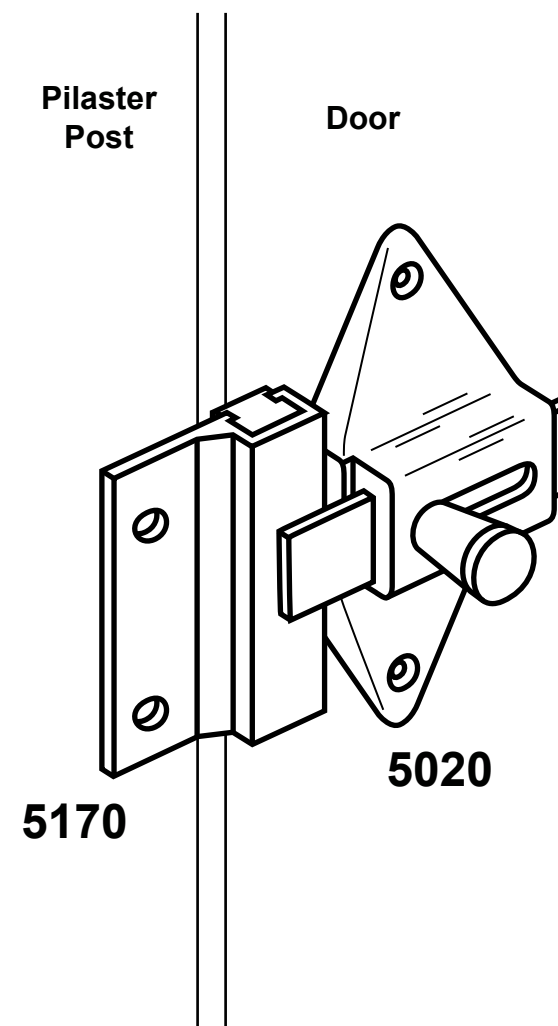

**INSWING
APPLICATION**

