

# INSTRUCTIONS FOR INSTALLING 19000, 19001, 19003 DOOR HARDWARE

CHECK ALL DIMENSIONS CAREFULLY.

1. Drill hole for top hinge pin using a 7/32" dia. drill. (see warning below)
2. The centerline for the top and bottom should be 1" from the edge of the door AFTER the laminate is applied.

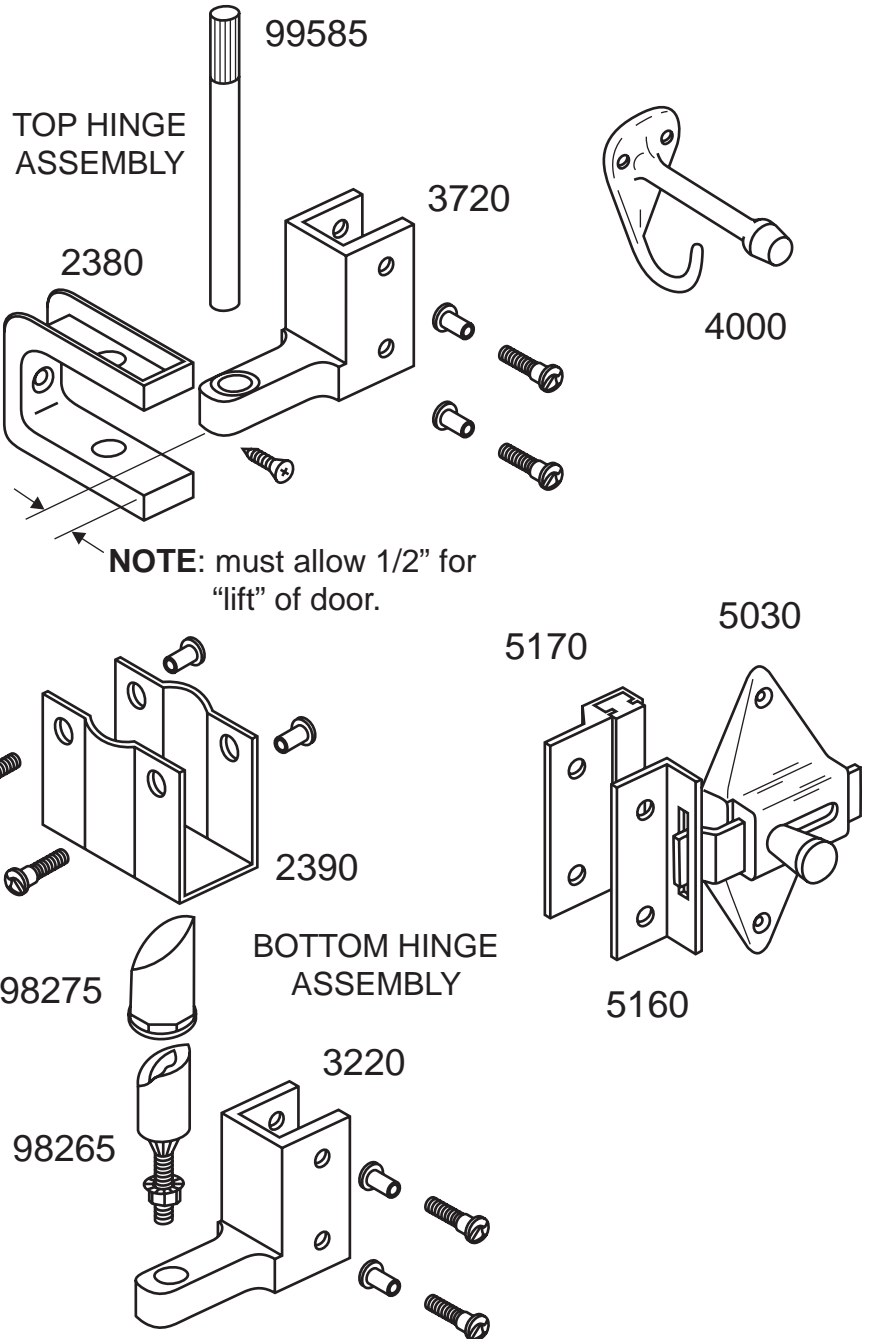
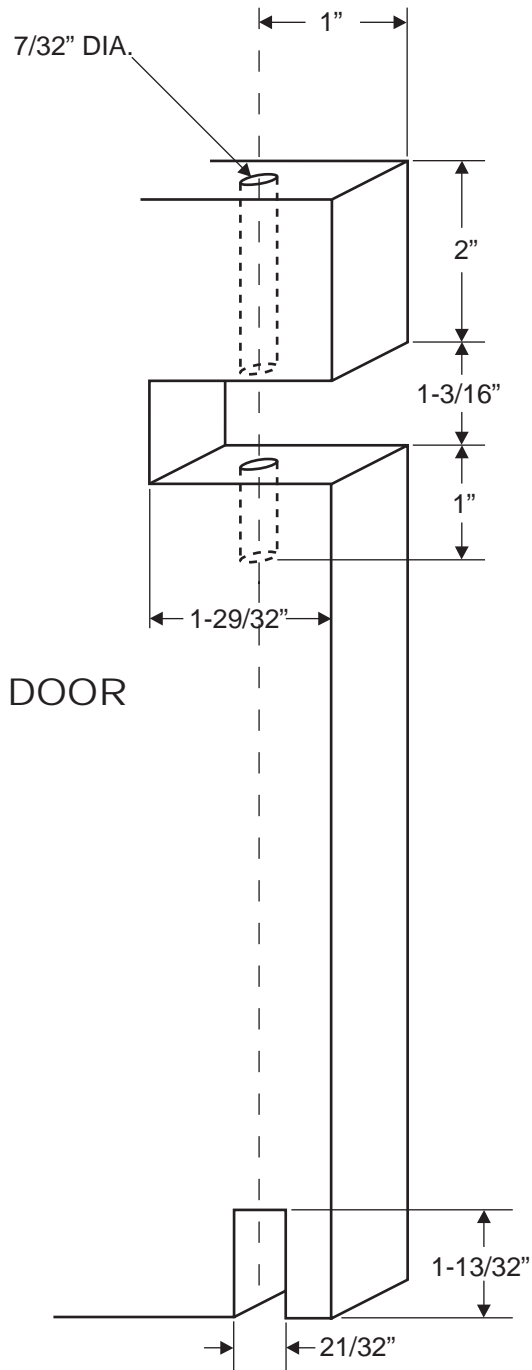

## WARNING:

- The limit of swing of this hardware is 110 degrees. This hardware should not be used on outswinging doors where there is no provision to stop the swing of the door at 110 degrees. After installation of the door, check to make sure that the door is stopped by a wall or other positive stop (such as a Jacknob pilaster door stop [# 4151]) before contact is made between the hinge brackets and the door escutcheons.
- The # 99585 hinge pin must fit tightly (a "press" fit) to prevent "walking out".
- Must allow 1/2" between bottom of (Top Hinge) and (Top Insert) for "lift" of door.
- Failure to heed the above warnings can result in failure of the door and serious injury to patrons.



\* 1 0 2 6 0 5 \*