

SPECIFICATIONS

GENERAL

Remote type, electric refrigerated, water chiller unit. Chilling capacity of 19.8 gallons per hour of 50°F drinking water, based upon 80°F inlet water and 90°F ambient.

Compact, highly efficient water chiller units are designed for use where large quantity of chilled water is required. May be located in a service area to serve up to three remote outlets (within 15 feet of chiller recommended). Also recommended for photo-processing, medical or experimental laboratories and a pre-cooler for beverage dispensing.

NO LEAD DESIGN

THIS WATER CHILLER COMPLIES WITH THE LEAD-FREE DEFINITION IN THE SAFE DRINKING WATER ACT OF 1986 AND LEAD CONTAMINATION CONTROL ACT OF 1988.

Elkay Water Chillers are manufactured with a waterway system utilizing copper components and completely lead-free materials. These waterways have no lead because all lead-containing materials, such as leaded brass, have been removed. All joints are brazed using silver solder only. No lead solder is permitted.

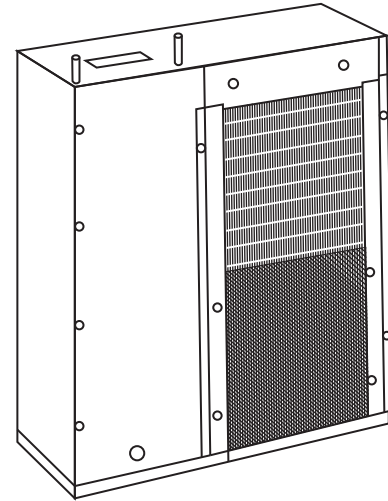

Model ERW20 Remote Chiller

CAPACITIESCHART

Model Number	Inlet Water Temp (°F)	*GPH of 50°F Drinking Water				No. People Served 50°F Drinking Water			Ship Wt. Lbs.
		Room Temperature °F				School & Office	Light Mfg.	Heavy Mfg.	
		7	8	9	1				
ERW20	70	27.7	27.7	27.7	27.7	495	297	238	100
	80	19.8	19.8	19.8	19.8				
	90	14.9	14.9	14.9	14.9				

*Based on 80°F Inlet Water Temperature.

Rated watts shown are based on operational (run) time, in accordance with A.R.I. Standard 1010 conditions. Specific applications will determine the actual watts consumed per hour. Watts consumed will be based on number of people served per hour (usage), ambient temperatures, and inlet water temperature.

COOLINGSYSTEM

Motor Compressor: Hermetically sealed, reciprocating type, 1/2 HP, 115VAC, 60Hz single phase. Sealed in lifetime oil supply.

Power: Rated 8.6 Amps; 670 Watts.

Condenser: Water cooled.

Cooling Unit: Combination tube-tank type. Tube portion is continuous coil of copper tubing. Tank is red brass. Tank volume is 4 gallons.

Refrigerant Control: Refrigerant HFC134a is controlled by accurately calibrated capillary tube for positively trouble-free operation.

Temperature Control: Enclosed adjustable thermostat is factory preset. Requires no adjustment other than for altitude requirements.

CONSTRUCTION

Cabinet: Rust-resistant, galvanized steel. Expanded, cold rolled steel grill is painted black.

Drain Plug: This chiller is provided with a plastic drain plug which incorporates an o-ring seal. This fitting is designed for potable water applications and should be replaced with a suitable fitting if chiller is used with more aggressive liquids.

5 YEAR LIMITED WARRANTY on the refrigeration system of the unit. Electrical components and water system are warranted for 12 months from date of installation. **Warranty pertains to drinking water applications only. Non-drinking water applications are not covered under warranty. Sample Certificate available on request.**

Note: In keeping with our policy of continuing product improvement, Elkay reserves the right to change materials, design and specifications without notice.

Elkay Electric Air Cooled Water Chillers are listed by Underwriters Laboratories Inc., approved by C.S.A., rated in accordance with A.R.I. Standard 1010 and meet all known federal and state plumbing codes.

STANDARDS

 Elkay Electric Air Cooled Water Coolers are listed by Underwriters Laboratories Inc. and comply with both Canadian and U.S. requirements.



Rated in accordance with A.R.I. Standard 1010 and meets all known federal and state plumbing codes.

This cooler is certified by WQA to lead-free compliance including NSF/ANSI 61 and 372.

This specification describes an Elkay product with design, quality and functional benefits to the user. When making a comparison of other producers' offerings, be certain these features are not overlooked.

ROUGH-IN DIMENSIONS

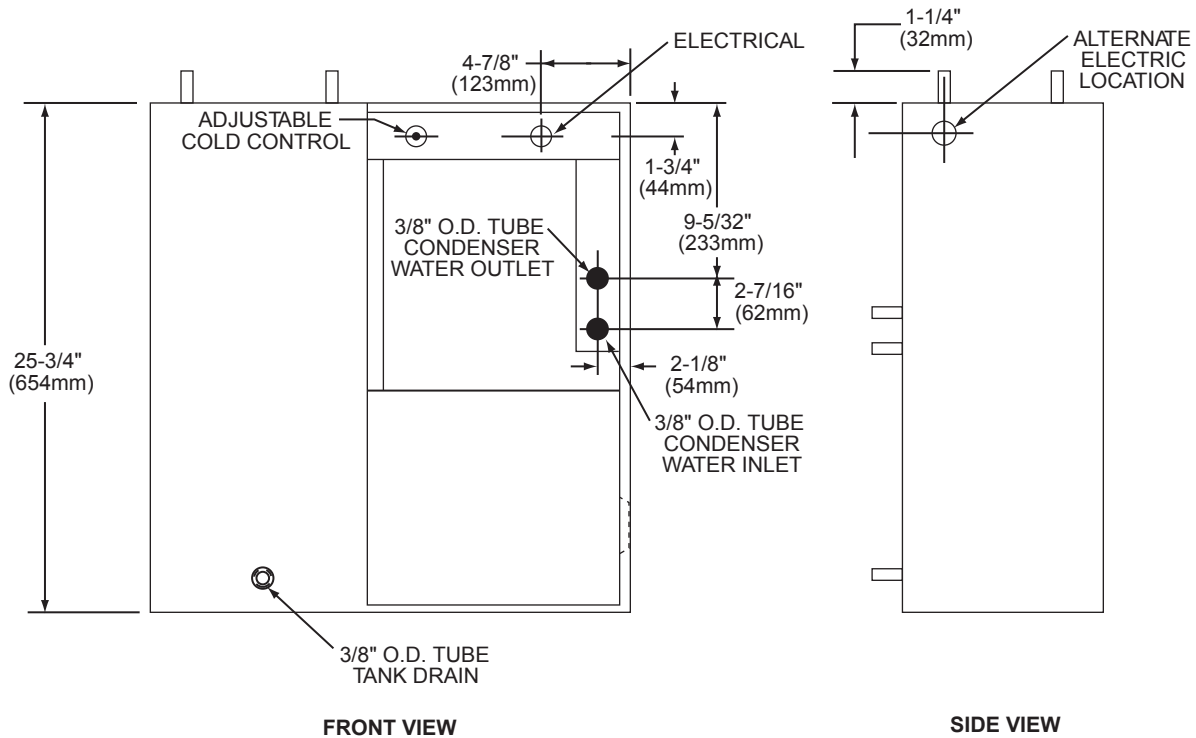
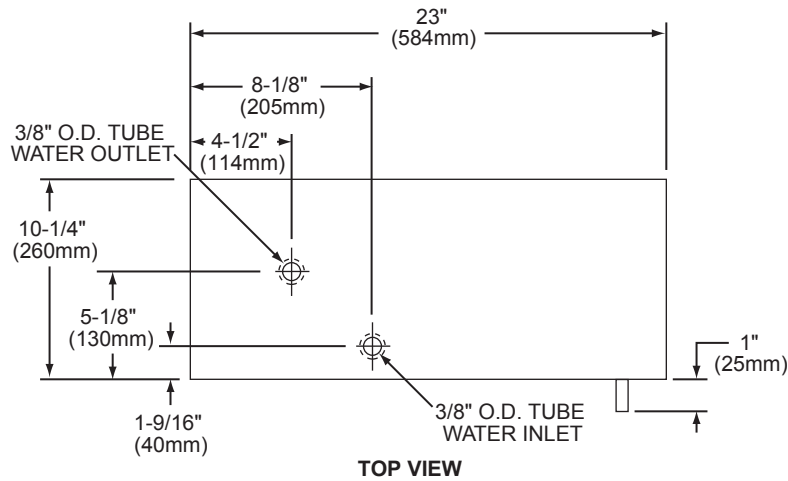

Drain Plug: This chiller is provided with a plastic drain plug which incorporates an o-ring seal. This fitting is designed for potable water applications and should be replaced with a suitable fitting if chiller is used with more aggressive liquids.

NOTE: This unit is intended for remote installation only. It is important to insure proper ventilation. Allow a minimum clearance of 12 inches (305mm) in front and 3 inches (76mm) in the rear of unit.