

# S402-1.28-SH-TS

DUAL FLUSH TOILET FLUSH VALVE  
(1.28 gpf / 1.0 Lpf)

## TruSABER w/ SMARTHANDLE

### Description

Chrome plated diaphragm operated flush valve for floor mounted or wall hung 1-1/2" top spud bowls.

SmartHandle enabled Saber Features:

- \*Pressing handle **DOWN** delivers 1.28 gpf/4.8 Lpf flush cycle for solid waste.
- \*Lifting handle **UP** delivers 1.0 gpf/3.8 Lpf for liquid waste (a water savings of 20%)
- \*Green colored Antimicrobial coating for germ resistance.

### Specifications

- Scratch proof recessed hex-nut designed cover
- Mashaerator, self-cleaning bypass, Diaphragm.
- Regulating screw for "True-in-the-Field" water conservation
- 1" vandle proof TruStop ball valve designed angle control stop with TruChek.
- Sweat adapter kit.
- Removeable main valve seat.
- ADA compliant metal "Rubberflex" oscillating handle.
- All rubber material made of chloramine resistant material
- Slip-Joint adjustable tailpiece.
- Vacuum breaker.
- Wall flange, spud nut and spud flange for 1-1/2" top spud.

### Variations

- SM - Side mounted battery powered sensor actuator
- T6 -Wall flange with allen set screw
- T36 -Solid ring wall support for flush connection
- T46 -Split ring wall support for flush connection
- VPS -Vandal Proof Control Stop with Key
- Logo - Customized Cover Cap w/ Logo

Valve is certified to be in compliance to the applicable sections of ASSE 1037 and ANSI/ASME 112.19.2

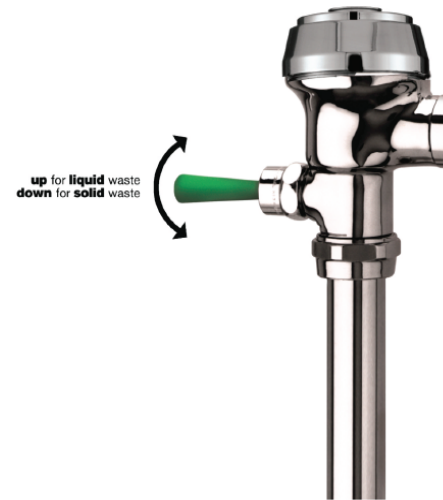

Patented TruStop Control Stop

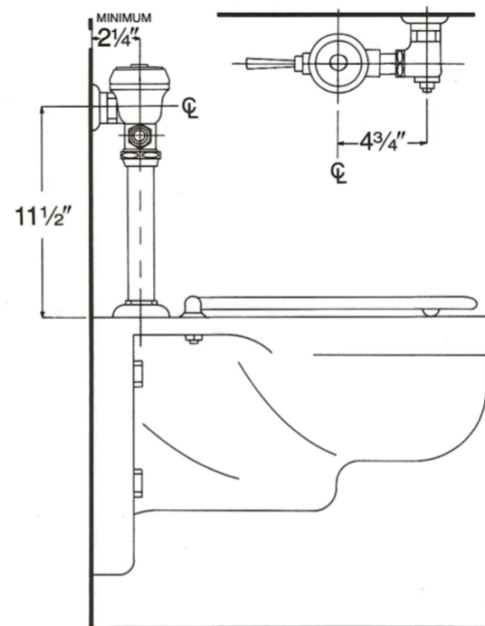

ASSE 1037