

Security shelf:

Model SA49 – Chase Mounted

Product Materials

CHASE MOUNTED SHELF: 14 gauge stainless steel in architectural satin finish. All welds are ground smooth, with polished corners and burr-free edges.

Overall dimensions: 16" W x 2-9/16" H x 4" D.

Installation

Verify all rough-in dimensions prior to installation. Back of shelf has welded anchor nuts to receive threaded studs (provided).

Standard Selections

WALL THICKNESS (must specify)
<input type="checkbox"/> Specify Thickness: _____

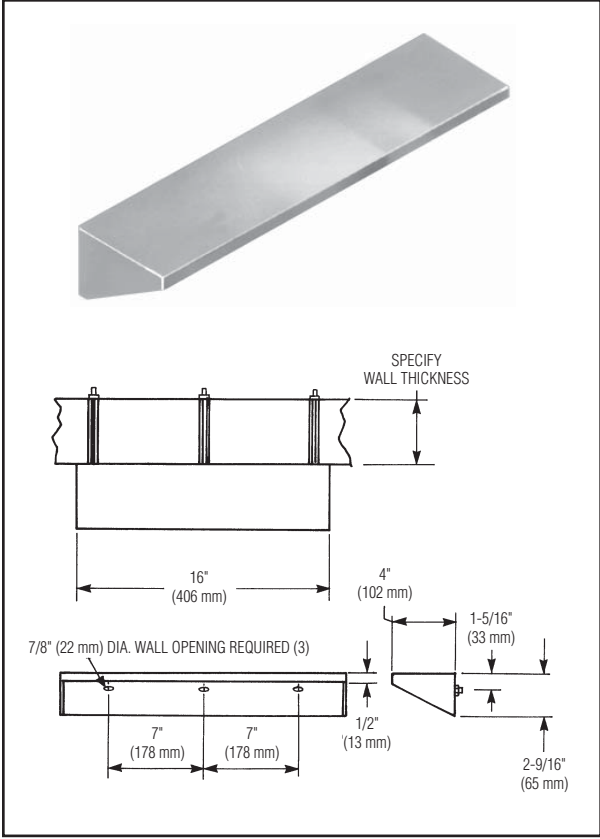

Washroom Accessories
Document No. 9270