

Adjustable tilt mirror with welded corners:

Model 782-XXXX (Specify width and height)

Product Materials

FRAME: one-piece roll-formed stainless steel, 3/4" x 3/4" angle with corners welded, ground and polished smooth to a satin finish. Double strength continuous integral stiffeners on all sides for added strength. Bevel on front of angle secures frame flush against mirror. Two 1/4" barrel butt hinges welded to bottom of frame.

BACK: galvanized steel, secured to frame with concealed screws.

MIRROR: first quality 1/4" float glass, thermosetting infrared-cured paint backing with Poly-Glaze protective finish. Manufactured in accordance with ASTM C 1036 and ASTM C 1503. The back of the mirror is protected by a sheet of 1/4" extruded polystyrene, which is placed between the mirror and the galvanized steel.

SUPPORT BRACKETS: heavy gauge stainless steel, electro-polished. Self-locking brackets securely riveted to frame.

Optional Features

Features	Suffix
<input type="checkbox"/> 1/4" tempered glass mirror in lieu of polished float glass mirror*	-2
<input type="checkbox"/> Laminate glass	-3
<input type="checkbox"/> Highly polished No. 8 architectural finish, 20 gauge stainless steel in lieu of polished float glass mirror	-4
<input type="checkbox"/> Bright annealed 20 gauge stainless steel in lieu of polished float glass mirror	-5
<input type="checkbox"/> Plexiglass	-6

*Either the Length (L) or the Width (W) must be greater than 25".

- An inherent characteristic of a manufacturing process for tempered glass is distortion which may vary from mirror to mirror.
- Stainless steel mirrors will differ in optic quality from glass mirrors.
- In larger sizes, stainless mirrors are subject to distortion and/or "oil canning" for which Bradley Corporation cannot accept responsibility.

Installation

Verify all rough-in dimensions prior to installation. Secure lower hinges to wall with screws (included) at holes provided. Provide in-wall backing at mounting screw locations. Mount top brackets to permit full arm extension.

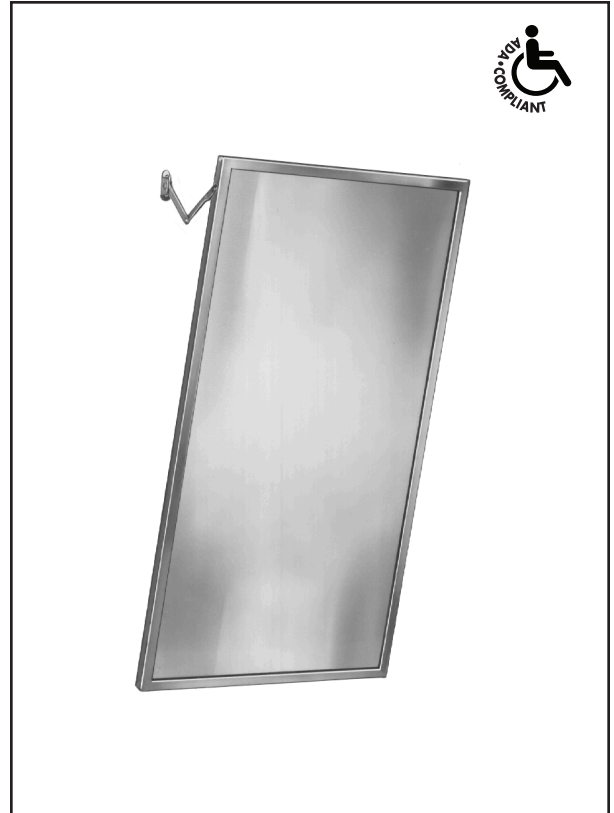

Guide Specification

Adjustable tilt mirror shall be framed with heavy gauge, one-piece roll-formed 3/4" x 3/4" stainless steel angle with double strength continuous integral stiffeners. Welded corners shall be polished to a uniform satin finish. Mirror shall be of first quality 1/4" float glass guaranteed for 15 years against silver spoilage and protected by a shock-absorbing, waterproof filler with Poly-Glaze protective finish. Self-locking adjustable support brackets shall be polished stainless steel and riveted to frame.

Adjustable Tilt Framed Mirror shall be Bradley Model 782-_____ " W x _____ " H (specify width and height).

Model 782 series adjustable tilt mirrors can be fabricated to a maximum size of 36"W x 48"H.

ADA Compliant

- Consult local and national accessibility codes for proper installation guidelines.
- Conformity and compliance to local and national codes is the responsibility of the installer.

**Washroom Accessories
Document No. 8795**

Dimensions

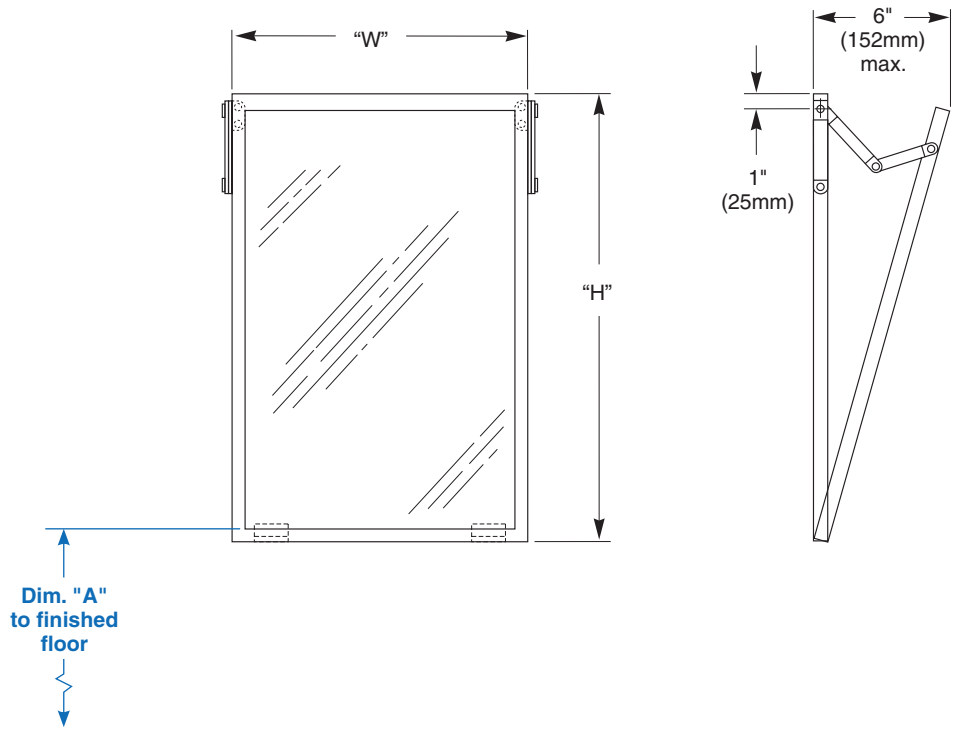

Dim. "A" Key Surface:	For Dim. "A"	Bottom of Unit
Mirror's bottom edge of the reflecting surface to finished floor	40" (1016mm)	39¼" (997mm)
	37" (940mm)	36¼" (921mm)
	34" (864mm)	33¼" (845mm)
Rough wall opening:		
Surface Mount:	No rough wall opening, see overall dimensions	

Washroom Accessories
Document No. 8795