



T&S BRASS AND BRONZE WORKS, INC.
 2 Saddleback Cove / P.O. Box 1088
 Travelers Rest, SC 29690

Model No.

B-CVV1-2

Item No.

Travelers Rest, SC: 800-476-4103 • Simi Valley, CA: 800-423-0150 • Fax: 864-834-3518 • www.tsbrass.com

This Space for Architect/Engineer Approval

Job Name _____ Date _____

Model Specified _____ Quantity _____

Customer/Wholesaler _____

Contractor _____

Architect/Engineer _____

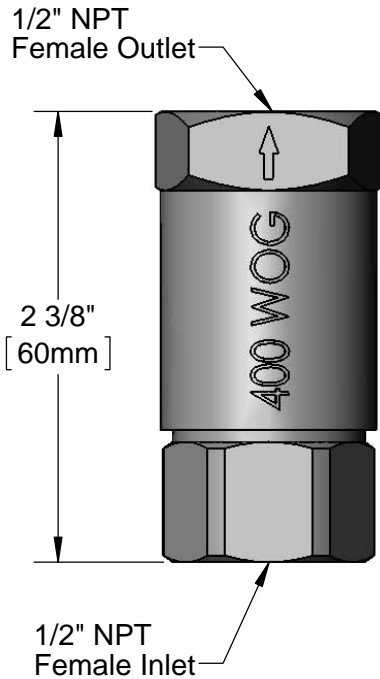
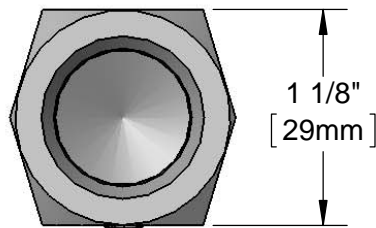
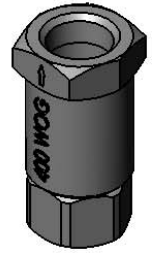

Notes:

1. Maximum Pressure 400 PSI, Maximum Temperature 200° F
2. Not to be Used for Natural Gas Applications.

Product Specifications:

Vertical Check Valve for Water Use Only w/ 1/2" NPT Inlet & Outlet

Product Compliance:

ASME A112.18.1 / CSA B125.1
 NSF 61 - Section 9
 NSF 372 (Low Lead Content)

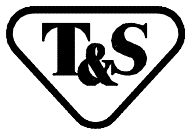

T&S BRASS AND BRONZE WORKS, INC.

2 SADDLEBACK COVE / P.O. BOX 1088 / TRAVELERS REST, SC 29690

PHONE 800-476-4103

FAX 864- 834-3518



REG.#A2601
ISO #9002

Model No.

B-CW-3/4

Item No.:

Job Name:

Architect/Engineer Approval:

Notes:

3/4" NPT FEMALE INLET
GAGE FIT ± 1 TURN

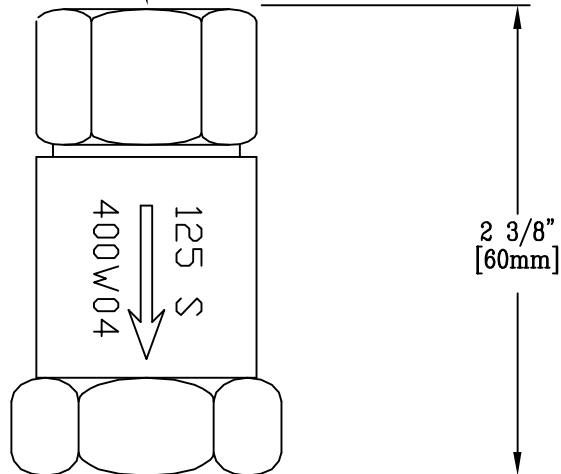

3/4" NPT FEMALE OUTLET
GAGE FIT ± 1 TURN

NOTES:

1. MAXIMUM PRESSURE 400 PSI AT 200° F
2. NOT TO BE USED FOR NATURAL GAS APPLICATIONS.

Product Description:

VERTICAL CHECK VALVE FOR WATER USE ONLY
WITH 3/4" NPT INLET & OUTLET

Drawn:

WJS

Approved

CA

Checked

ARY

Scale:

1' = 1'

Date:

10/2/95

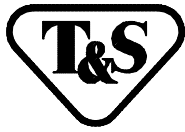

T&S BRASS AND BRONZE WORKS, INC.
 2 SADDLEBACK COVE / P.O. BOX 1088 / TRAVELERS REST, SC 29690
 PHONE 800-476-4103 FAX 864- 834-3518



Model No.

B-CW-3/8

Item No.:

REG.#A2601
ISO #9002

Job Name:

Architect/Engineer Approval:

Notes:

3/8" NPT FEMALE INLET

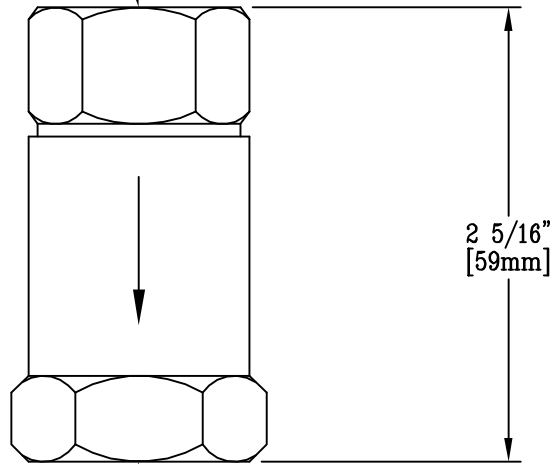

2 5/16"
[59mm]

3/8" NPT FEMALE OUTLET

NOTES:

1. MAXIMUM PRESSURE 400 PSI AT 200° F
2. NOT TO BE USED FOR NATURAL GAS APPLICATIONS.

Product Description:

VERTICAL CHECK VALVE FOR WATER USE ONLY
 WITH 3/8" NPT INLET & OUTLET

Drawn:

WJS

Approved

MVW

Checked

ARY

Scale:

1' = 1'

Date:

8-13-97



T&S BRASS AND BRONZE WORKS, INC.
 2 Saddleback Cove / P.O. Box 1088
 Travelers Rest, SC 29690

Model No.

B-CVH1-2

Item No.

Travelers Rest, SC: 800-476-4103 • Simi Valley, CA: 800-423-0150 • Fax: 864-834-3518 • www.tsbrass.com

This Space for Architect/Engineer Approval

Job Name _____ Date _____

Model Specified _____ Quantity _____

Customer/Wholesaler _____

Contractor _____

Architect/Engineer _____

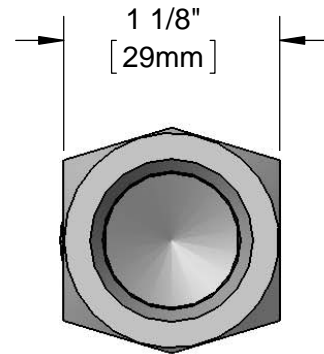
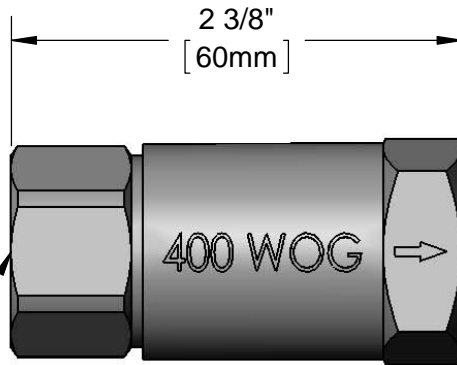

1/2" NPT
Female Inlet

1/2" NPT
Female Outlet

Notes:

1. Maximum Pressure 400 PSI, Maximum Temperature 200° F
2. Not to be Used for Natural Gas Applications.

Product Specifications:

Horizontal Check Valve for Water Use Only w/ 1/2" NPT Inlet & Outlet

Product Compliance:

ASME A112.18.1 / CSA B125.1
 NSF 61 - Section 9
 NSF 372 (Low Lead Content)



T&S BRASS AND BRONZE WORKS, INC.

2 SADDLEBACK COVE / P.O. BOX 1088 / TRAVELERS REST, SC 29690

PHONE 800-476-4103

FAX 864- 834-3518



REG.#A2601
ISO #9002

Model No.

B-CVH-3/4

Item No.:

Job Name:

Architect/Engineer Approval:

Notes:

3/4" NPT FEMALE INLET
GAGE FIT ± 1 TURN

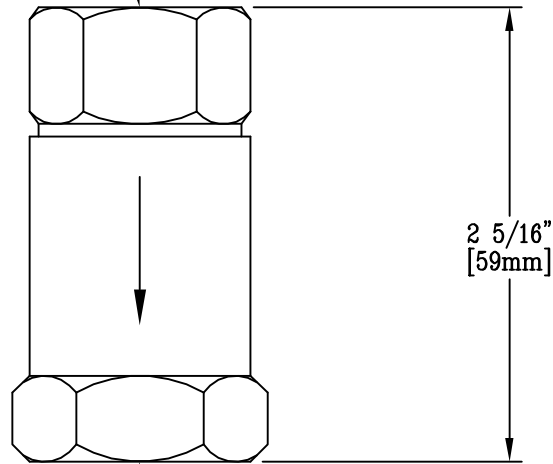

3/4" NPT FEMALE OUTLET
GAGE FIT ± 1 TURN

NOTES:

1. MAXIMUM PRESSURE 400 PSI AT 200° F
2. NOT TO BE USED FOR NATURAL GAS APPLICATIONS.

Product Description:

HORIZONTAL CHECK VALVE FOR WATER USE ONLY
WITH 3/4" NPT INLET & OUTLET

Drawn:

WJS

Approved

CA

Checked

ARY

Scale:

1' = 1'

Date:

10/2/95



T&S BRASS AND BRONZE WORKS, INC.
 2 SADDLEBACK COVE / P.O. BOX 1088 / TRAVELERS REST, SC 29690
 PHONE 800-476-4103 FAX 864- 834-3518



Model No.

B-CVH-3/8

Item No.:

REG.#A2601
 ISO #9002

Job Name:

Architect/Engineer Approval:

Notes:

3/8" NPT FEMALE INLET

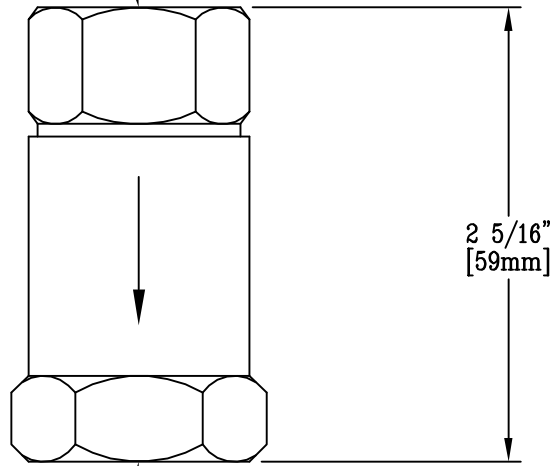

3/8" NPT FEMALE OUTLET

NOTES:

1. MAXIMUM PRESSURE 400 PSI AT 200° F
2. NOT TO BE USED FOR NATURAL GAS APPLICATIONS.

Product Description:

HORIZONTAL CHECK VALVE FOR WATER USE ONLY
 WITH 3/8" NPT INLET & OUTLET

Drawn:

WJS

Approved

MVW

Checked

ARY

Scale:

1' = 1'

Date:

8-13-97