

AutoFlush® Unit for Urinals & Toilets

Air Delights

INSTALLATION INSTRUCTIONS

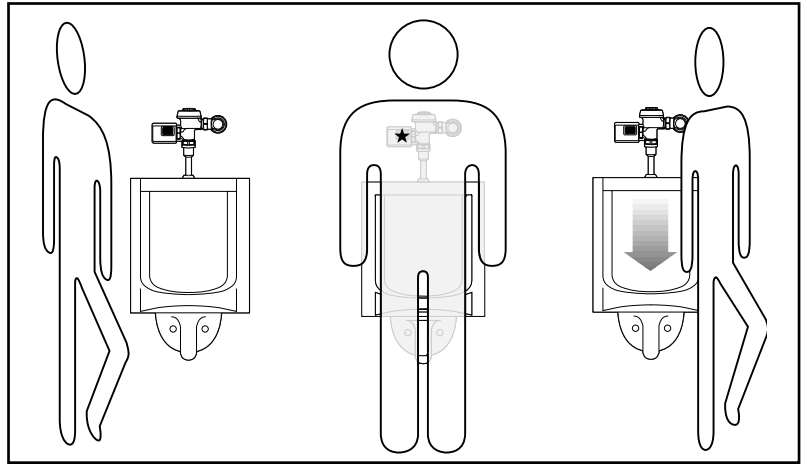
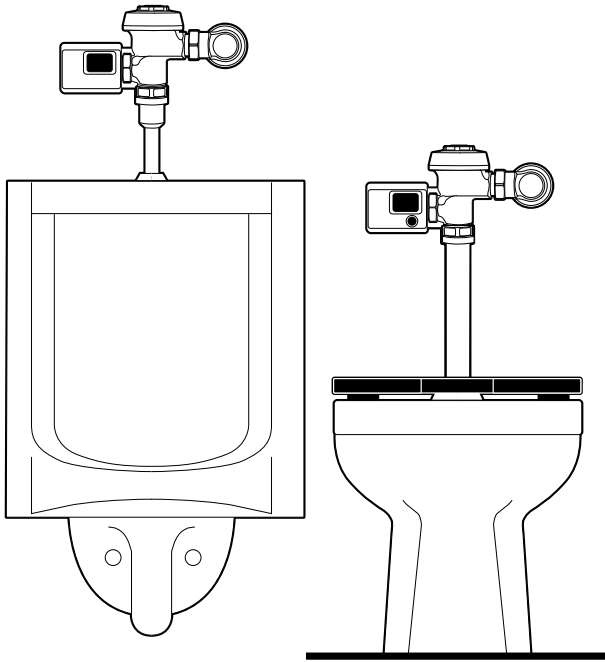

The AutoFlush™ sends out a continuous infrared beam that is reflected back by the presence of a person in front of the urinal or toilet. "Object Lock" technology differentiates between someone walking past the unit or actually using the fixture.

AUTOFLUSH COMPONENTS

AutoFlush for Urinals

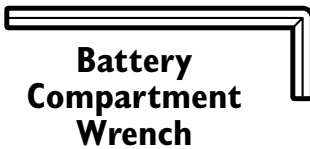
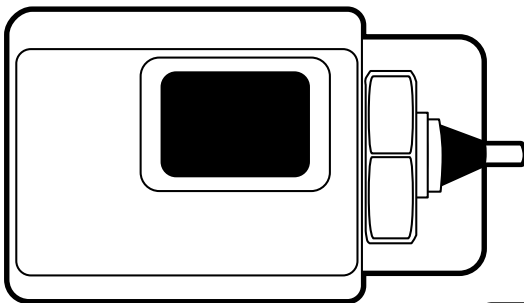

Battery
Compartment
Wrench

AutoFlush for Toilets

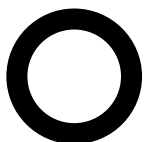
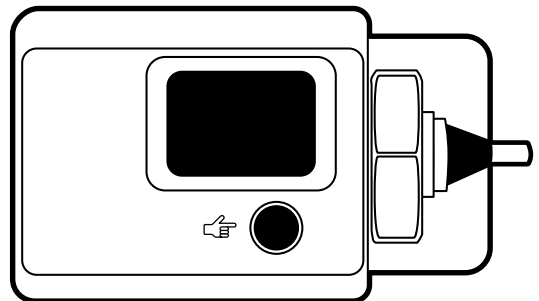

Collar
Gasket

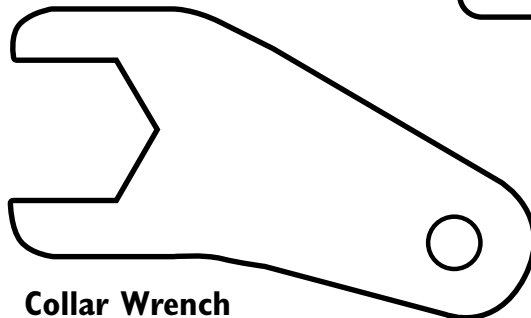

Collar Wrench

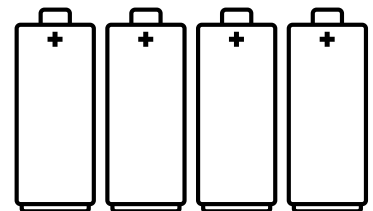

4 "C" Alkaline Batteries

1 INSTALLATION

Using the supplied collar wrench, remove handle from flush valve.

Note: On some flush valves with a faulty air vent, or recently flushed valve, be prepared to collect a small amount of water with a rag or sponge placed under the handle.

Place collar gasket into collar nut and attach the AutoFlush unit where the handle was removed. Tighten collar nut with supplied collar wrench.

Note: Save handle in the event you wish to reuse for service of AutoFlush.

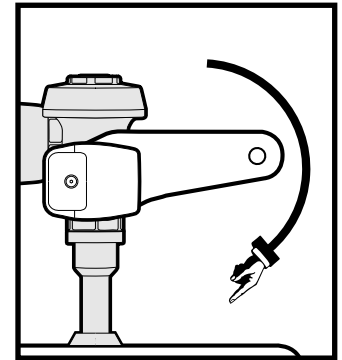
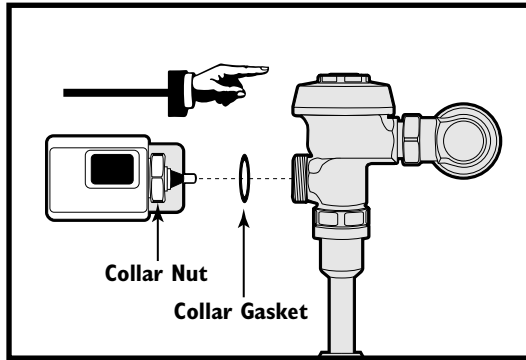
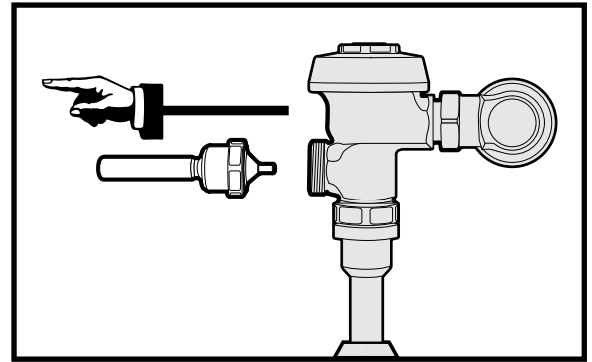
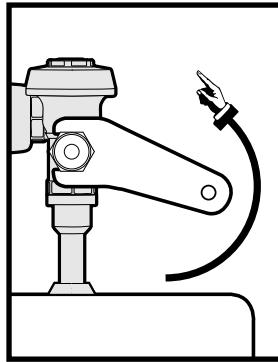

2 ACTIVATION

Using supplied battery compartment wrench, remove battery compartment from the AutoFlush unit.

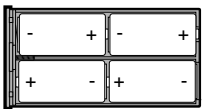

Load batteries into compartment tray (note position of batteries in tray), and reinstall battery tray into the AutoFlush unit.

Secure tray with battery compartment wrench. The last three turns of the wrench will activate the AutoFlush unit. The Purinel NoTouch AutoFlush System is now operational.

Your AutoFlush unit comes preset from the factory. If special circumstances require adjustment of the activation distance, see Appendix A—Adjusting your AutoFlush.

The AutoFlush unit has a 7 minute start-up sequence in which the Object Lock Sensor will flash the User-In-View green L.E.D. continuously as long as a user is in view. After the start-up sequence is completed and when the Object Lock Sensor has a user in view, the User-In-View green L.E.D. will flash only 3 times after 5 seconds delay. This delay prevents needless flushes when someone walks by.

Remove Battery Compartment

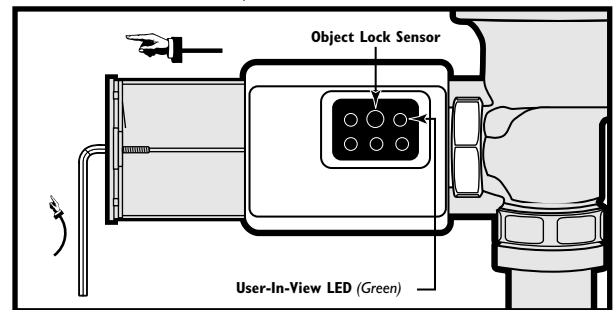

Install Battery Compartment

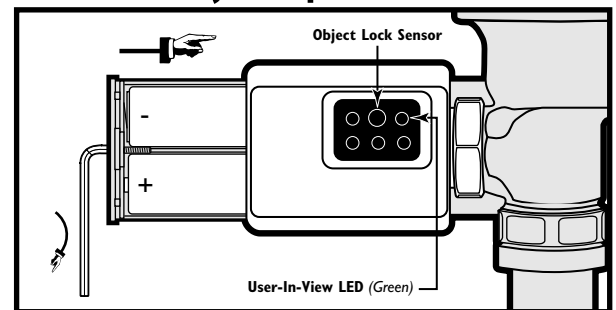

VISUAL INDICATOR GUIDE

USER-IN-VIEW L.E.D. (Green light flashes 3 times, after 5 second delay, when a user is in view. The green light flashes constantly when a user is in view during the 7 minute start up sequence).

OBJECT LOCK SENSOR

BATTERY L.E.D. (Yellow light flashes indicating it is time to replace batteries with 4 new "C" batteries).

COURTESY MANUAL FLUSH BUTTON
(Allows manual activation of flush when needed—Toilet model only).

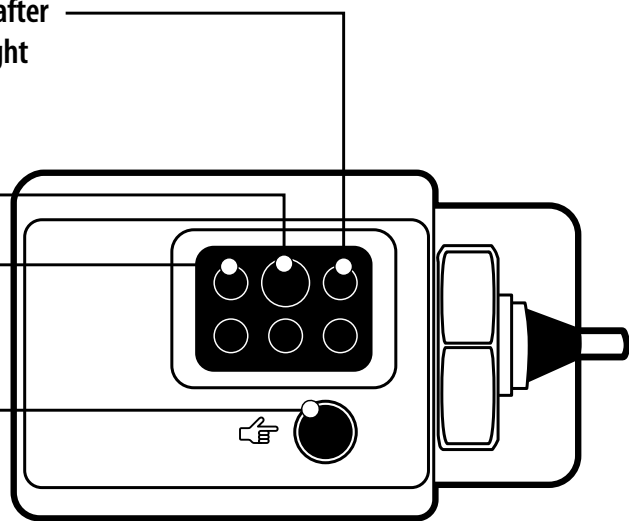

ADJUSTING YOUR AUTOFLUSH

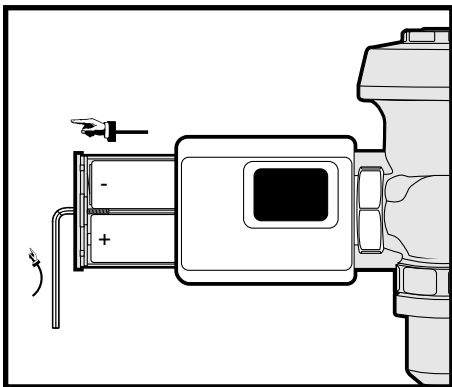

Use battery compartment wrench to remove battery compartment tray.

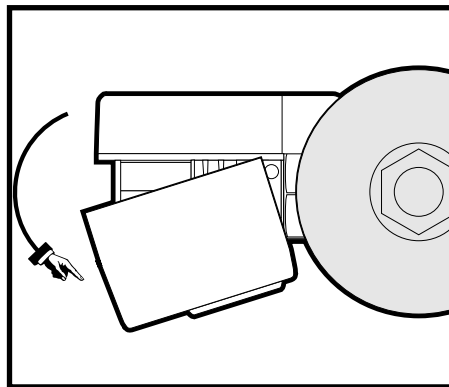

Pull cover off by rotating battery side forward and out.

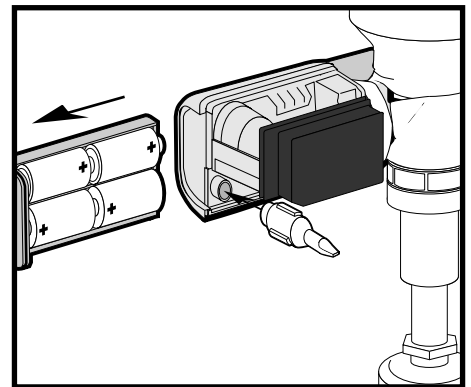

Sensor Adjustor Tool comes in a built in storage pocket. Replace after use.

TO CHANGE ACTIVATION DISTANCE FOR THE OBJECT LOCK SENSOR:

- 1 Remove battery compartment tray as shown at left.
- 2 Remove cover and sensor adjustor tool as shown at left.
- 3 Replace battery compartment in AutoFlush to activate unit.
- 4 Press sensor range reset button shown on next page (the green L.E.D. will flash continuously when it has an object in view for the seven minute reset period).
- 5 Stand at desired activation distance.
- 6 Use sensor adjustor tool and turn Distance Adjustment Screw all the way down and then turn slowly up until green L.E.D. begins to flash.
- 7 Ensure Object Lock Sensor is not detecting stall door or wall by closing door, stepping out of sensor path and making sure green L.E.D. is not flashing. If sensor locks onto door or wall, unit will not flush properly. Shorten activation distance.
- 8 Remove battery compartment, replace sensor adjustor tool and cover. Replace battery compartment tray to reactivate AutoFlush unit.
- 9 After 7 minute start-up sequence, the green L.E.D. will flash only 3 times when a user is in view (after a 5 second delay).

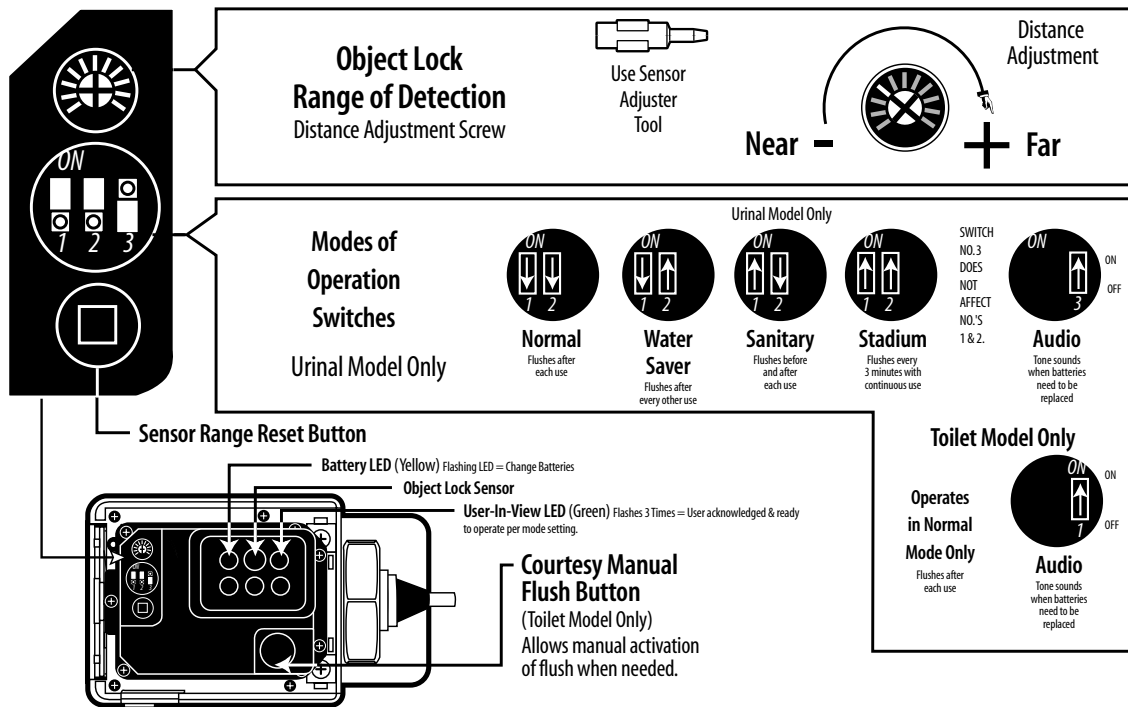

TROUBLE SHOOTING GUIDE

PROBLEM	CAUSE	SOLUTION TO PROBLEM
Green L.E.D. (light) flashes 3 times when there are no users	Front of Object Lock Sensor is covered or Object Lock Sensor is set too far out, registering the opposite wall or door as a user	Remove item covering sensor or adjust Object Lock Sensor activation distance. (See Appendix B. Adjusting the AutoFlush)
Green L.E.D. (light) flashes continuously when Object Lock Sensor is activated by a user	AutoFlush unit is in 7 minute start up mode (when first activated) or Sensor Range Reset Button has been depressed	Green L.E.D. (light) will flash only 3 times acknowledging a user is in view after the 7 minute start up mode
Orange L.E.D. (light) flashes	Batteries need replacing	Replace batteries
Not enough water to fixture or too much water to fixture	Diaphragm damaged or valve control stop improperly adjusted	Replace diaphragm and/or adjust valve control stop
Valve will not operate	Object Lock Sensor range set to close to AutoFlush, batteries are dead, or water supply is turned off	Adjust Object Lock Sensor—Replace batteries—Turn water on.
Valve does not shut off	Dirt or debris preventing diaphragm from functioning properly	Remove dirt or debris, consult valve manufacturer's directions
Valve does not flush even after Object Lock Sensor has been adjusted	Dead batteries	Replace batteries.

Air Delights

www.airdelights.com

1-800-440-5556 • 1-503-643-8224 (Fax) • 11170 SW 5th Street, Suite 100. Beaverton, O R 97005