



# SINGLE CONTROL FAUCET Z81000

TAG \_\_\_\_\_



**Engineering Specifications: Zurn AquaSpec® Single Control Faucet Z81000**  
Polished chrome plated cast brass 4" [102mm] centerset single control lavatory faucet, a ceramic disc cartridge and a temperature limit stop. Unit is furnished with 2.2 GPM [8.3 L] pressure compensating aerator (complying with ANSI A112.18.1M Standard for flow), an ADA compliant lever handle, mounting hardware, 1/2" NPSM coupling nuts for standard lavatory risers, and pop-up hole plugged.

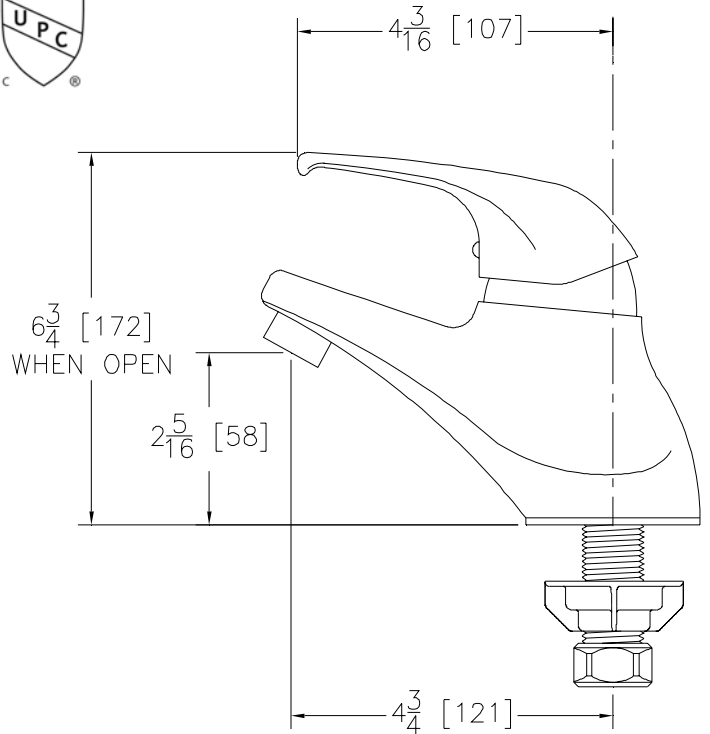
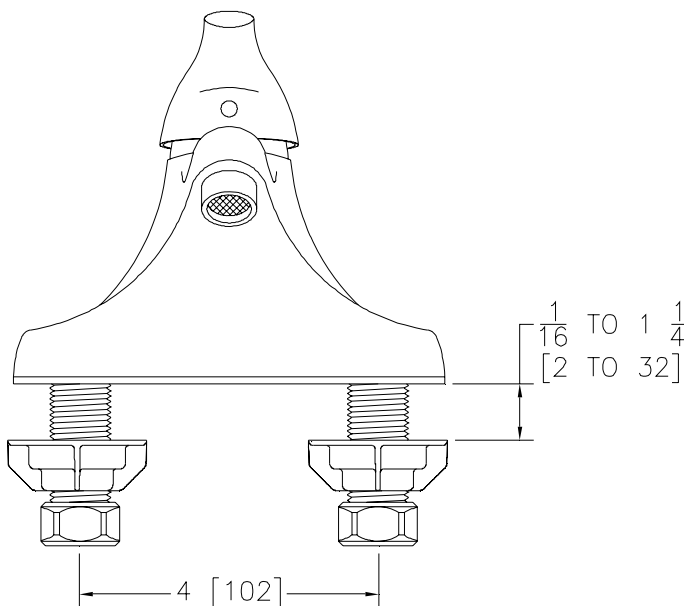
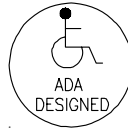

Note: All dimensions are for reference only. Do not use for pre-plumbing

## OPTIONAL ACCESSORIES

Suffix	Description
___ -EXT	Extended Handle
___ -G	1-1/4" [32mm] Grid Strainer Drain
___ -P	1-1/4" [32mm] Pop-up Drain
___ -PT	1-1/4" [32mm] Cast Brass P-Trap with a 7-1/2" [191mm] Long 17-Gauge Wall Bend
___ -1M	2.2 GPM [8.3 L] Pressure Compensating Male Aerator
___ -2M	2.2 GPM [8.3 L] Vandal-Resistant Pressure Compensating Male Aerator
___ -3M	0.5 GPM [1.9 L] Vandal-Resistant Pressure Compensating Male Aerator
___ -4M	2.2 GPM [8.3 L] Vandal-Resistant Pressure Compensating Male Laminar Flow
___ -5M	2.0 GPM [7.6L] Male Spray Outlet
___ -7M	1.0 GPM [3.8 L] Pressure Compensating Male Spray Outlet
___ -16M	1.0 GPM [3.8 L] Vandal-Resistant Pressure Compensating Male Spray Outlet
___ -17M	1.5 GPM [5.7 L] Vandal-Resistant Pressure Compensating Male Aerator
___ -18M	1.5 GPM [5.7 L] Vandal-Resistant Pressure Compensating Laminar Flow

AIR DELIGHTS, INC. ♦ COMMERCIAL BRASS OPERATION ♦ 9974 SW ARCTIC DR. ♦ BEAVERTON, OR. 97005

Phone: 1-800-440-5556 ♦ Fax: 1-503-643-8224 ♦ World Wide Web: www.airdelights.com

In Canada: ZURN INDUSTRIES LIMITED ♦ 3544 Nashua Drive ♦ Mississauga, Ontario L4V1L2 ♦ Phone: 503/352-1201 Fax: 503/643-8224

Rev. D Date: 8/1/06  
Dwg. No. 92071

C.N. No. 10481  
Product No. Z81000