



T&S BRASS AND BRONZE WORKS, INC.
 2 Saddleback Cove / P.O. Box 1088
 Travelers Rest, SC 29690

Model No.
BL-4250-02
 Item No.

Travelers Rest, SC: 800-476-4103 • Simi Valley, CA: 800-423-0150 • Fax: 864-834-3518 • www.tsbrass.com



ADA Compliant

NOTES:

1. Natural Gas Pressure: 0.5 PSIG Max.
 (For Natural Gas above 0.5 PSIG or Oxygen and Specialty Gases, use BL-4010-01 Gas Cock.)
2. Air Pressure: 125 PSIG Max.
3. Vacuum: 30 inches of Mercury Max.
4. Certified to ANSI Z21.15a / CSA 9.1a

This Space for Architect/Engineer Approval

Job Name _____ Date _____
 Model Specified _____ Quantity _____
 Customer/Wholesaler _____
 Contractor _____
 Architect/Engineer _____



209L-AIR
 Indexes
 Included



209L-VAC
 Indexes
 Included

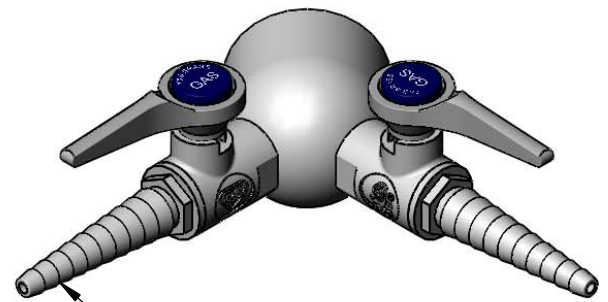
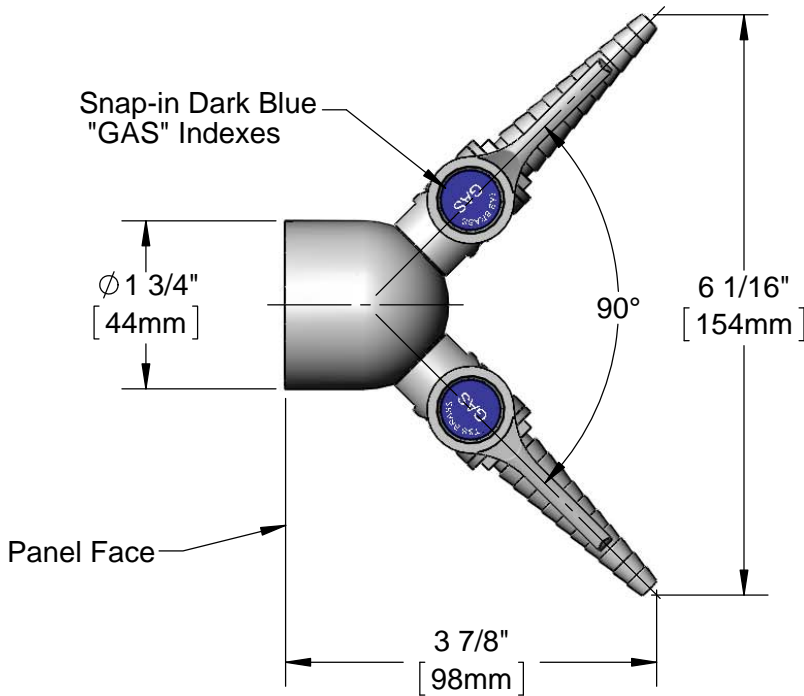

Serrated Tips Accept
 1/4" to 3/8" ID Hoses

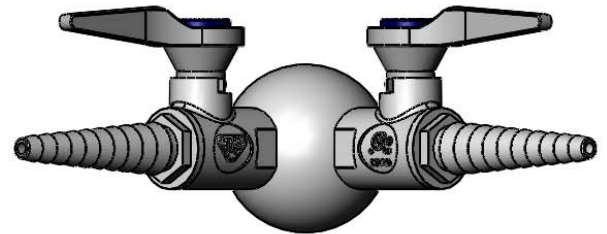
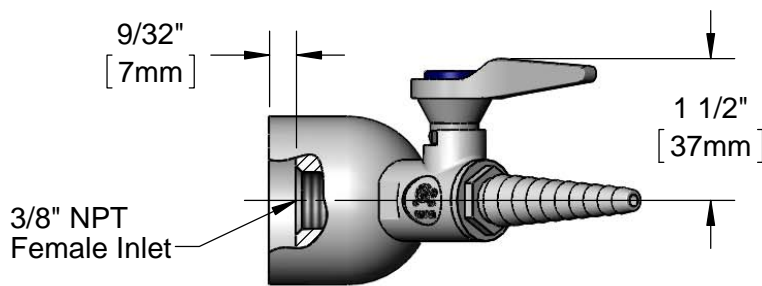

Product Specifications:
 Panel Flange w/ (2) 3/8" NPT Hose Cocks

Product Compliance:
 ANSI Z21.15a / CSA 9.1a
 ANSI A117.1 (ADA)



T&S BRASS AND BRONZE WORKS, INC.
 2 Saddleback Cove / P.O. Box 1088
 Travelers Rest, SC 29690

Model No.
BL-4250-02

Item No.

Travelers Rest, SC: 800-476-4103 • Simi Valley, CA: 800-423-0150 • Fax: 864-834-3518 • www.tsbrass.com

ITEM NO.	SALES NO.	DESCRIPTION
1	209L-AIR	Orange AIR Snap-In Index
2	209L-VAC	Yellow VAC Snap-In Index
3	209L-GAS	Dark Blue GAS Snap-In Index
4	BL-4000-01	Ball Valve Hose Cock w/ GAS, AIR & VAC Indexes

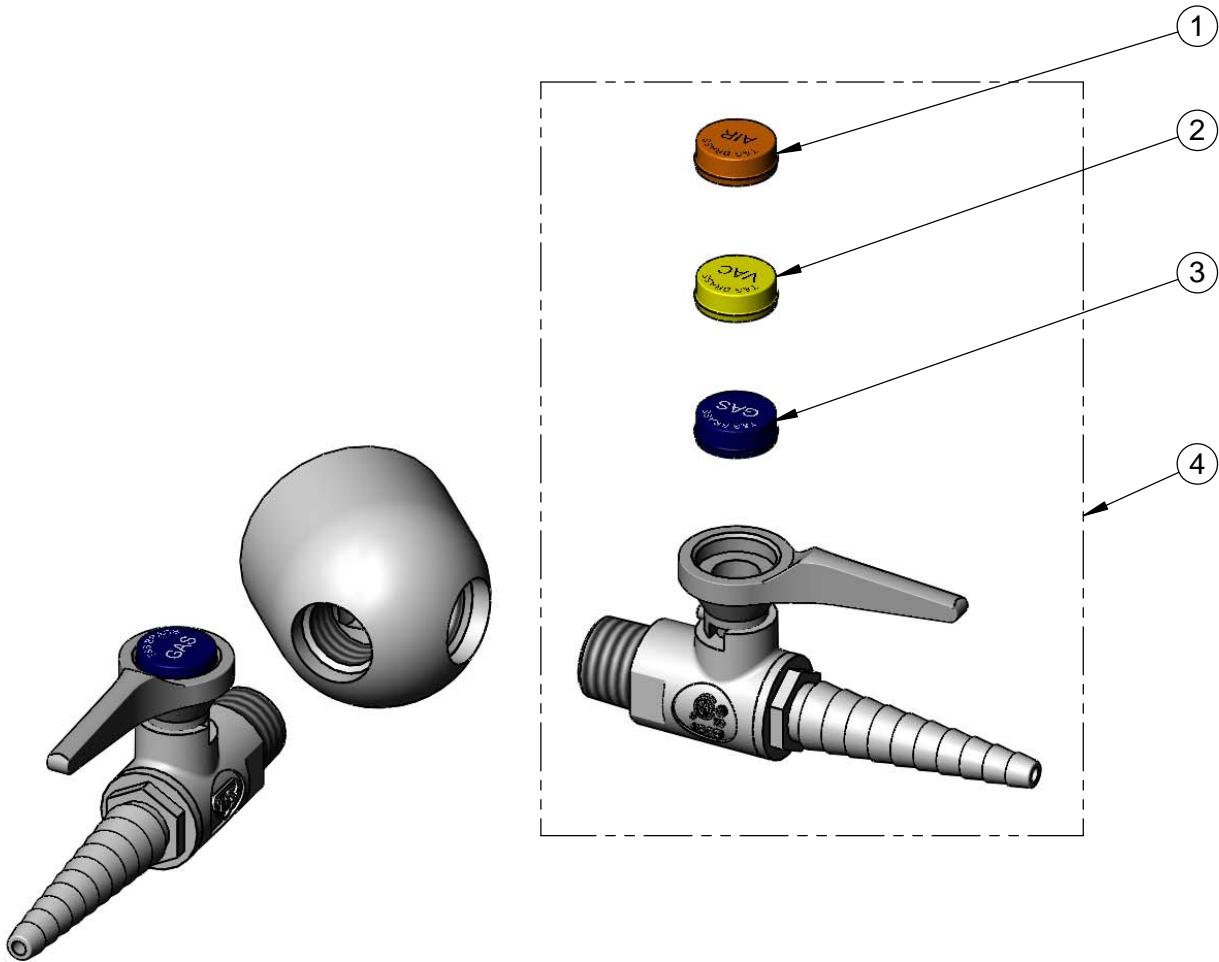

Product Specifications:
 Panel Flange w/ (2) 3/8" NPT Hose Cocks

Product Compliance:
 ANSI Z21.15a / CSA 9.1a
 ANSI A117.1 (ADA)



T&S BRASS AND BRONZE WORKS, INC.

2 SADDLEBACK COVE / P.O. BOX 1088 / TRAVELERS REST, SC 29690

PHONE 800-476-4103

FAX 864- 834-3518



REG.#A2601
ISO #9002

Model No.

BL-4250-05

Item No.:

Job Name:

Architect/Engineer Approval:

Notes:

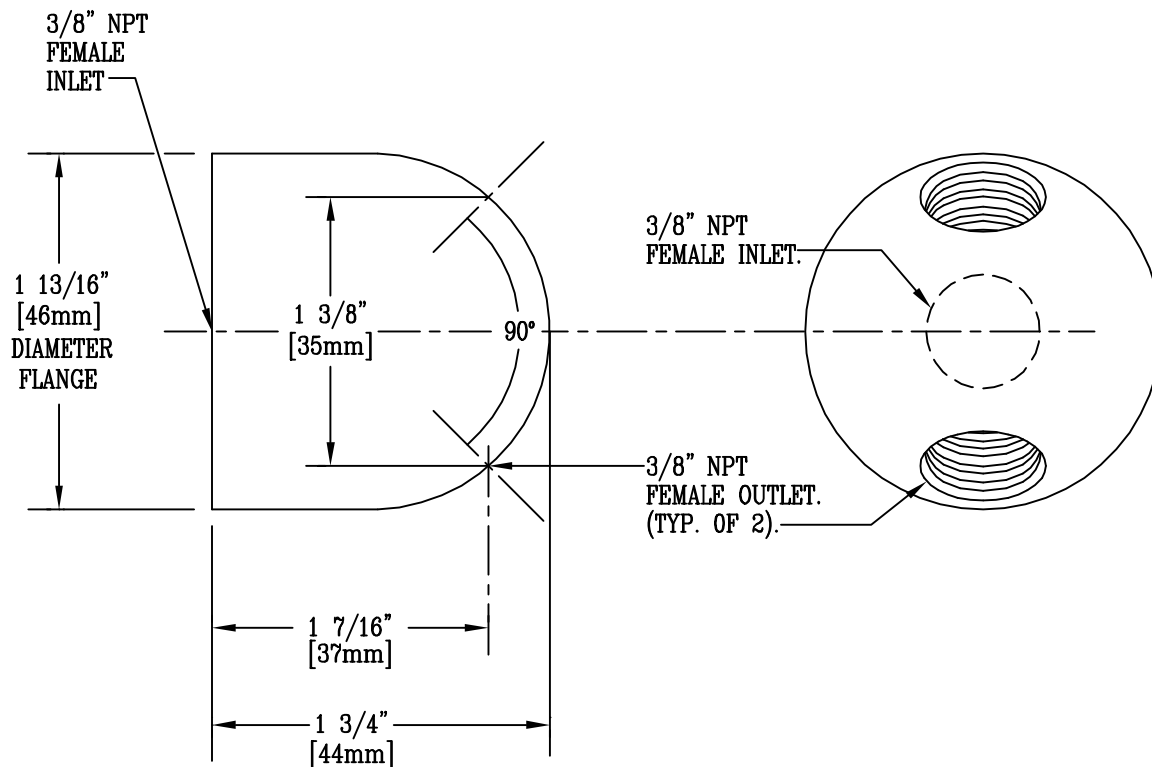

Product Description:

DOUBLE PANEL FLANGE WITH
3/8" NPT FEMALE INLET & OUTLET

Drawn:

WJS

Checked

JKD

Scale:

1' = 1'

Approved

CA

Date:

11/22/95