

AutoFlush[®]

for TANK TOILET Wired Model

Installation & Maintenance

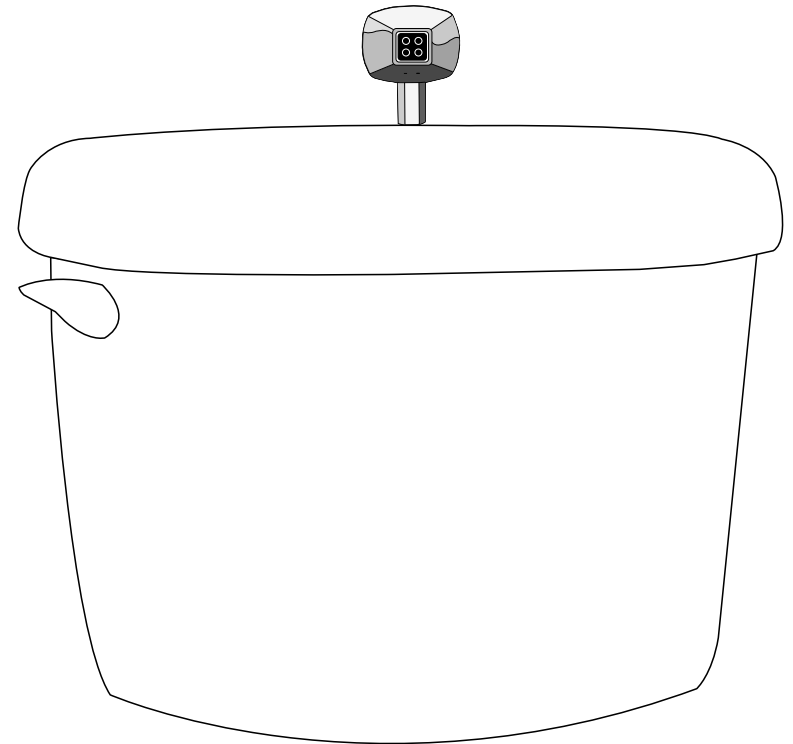

Looks Clean - Is Clean.™



TECHNICAL CONCEPTS

1 Components

1.1 Remove the AutoFlush components from the box and check to make sure you have all the parts.

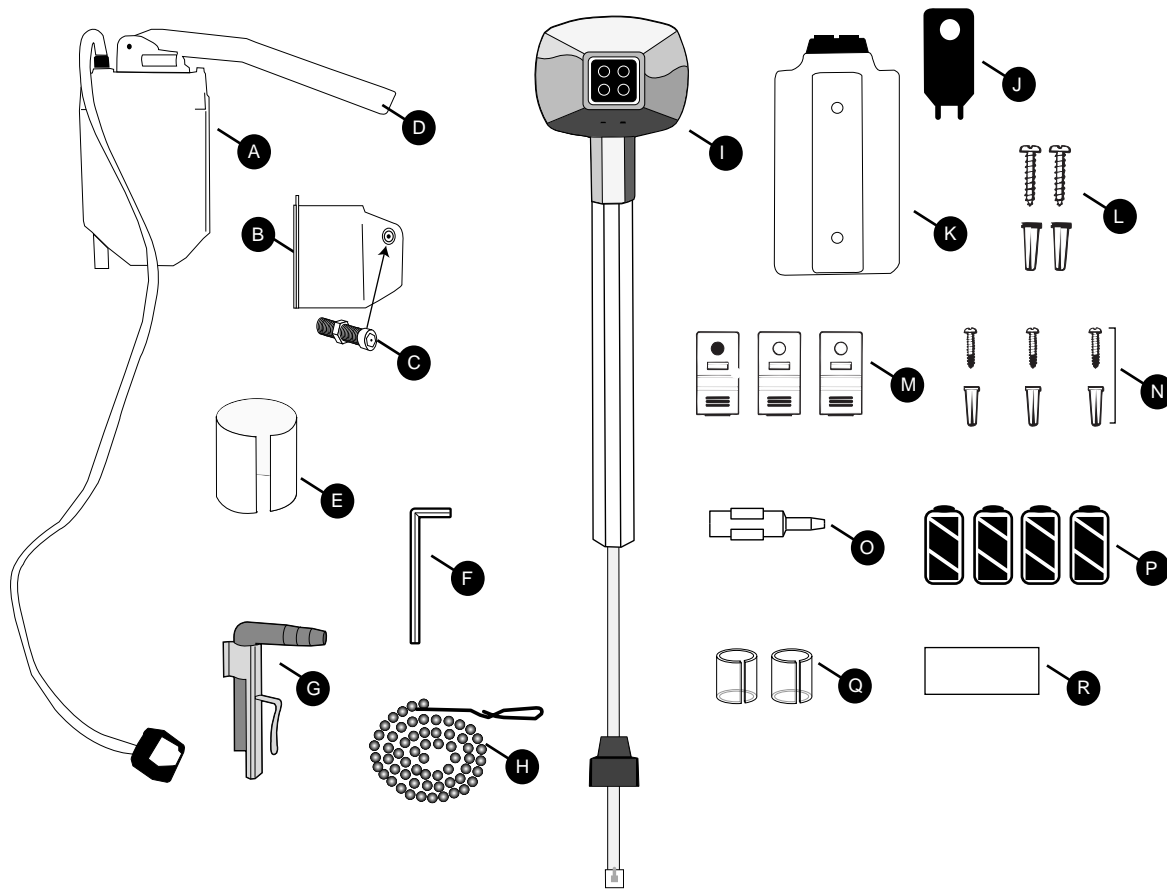

- A. Motor
- B. Motor Mount
- C. Hex Bolt in Motor Mount
- D. Motor Arm
- E. Plastic Spacer
- F. Allen Wrench
- G. Overflow Pipe Clip
- H. Bead Chain with Clip
- I. Sensor Assembly
- J. Sensor Cover Key
- K. Battery Compartment
- L. Battery Compartment screws and anchors (large- 2 ea)
- M. Wire Guides (3 ea)
- N. Screws and Anchors for Wire Guides (small-3 ea)
- O. Sensor Adjustment Tool
- P. Four (4) "D" cell Alkaline Batteries
- Q. Clear Plastic Shim (2 ea)
- R. Double-sided Tape

Tools required: Small Phillips screwdriver, pencil

2 Prior to Installation

- 2.1 Check that all existing toilet plumbing components are functioning properly. It is recommended to wear protective gloves when working inside the toilet tank.
- 2.2 Shut off water to toilet (usually found on the wall directly under the tank on the same side as the flush handle).
- 2.3 Flush toilet and hold handle down to remove as much water from the tank as possible. Listen to hear if the tank is refilling. If so, make sure the water is completely turned off.
- 2.4 Mark wall for sensor installation. Before removing the tank cover lift up the toilet seat cover, if the cover comes above the tank make a small pencil mark on the wall directly back from the top of the toilet seat cover. If the toilet seat does not come above the top of the toilet tank, then use the center and top of the toilet tank as a guide and make a small mark on the wall. Then mark 2 1/2" directly above the mark you just made. The mark will be used later in the installation as a guideline.
- 2.5 REMOVE the toilet tank cover and place it out of the way.
- 2.6 CLOSE toilet seat cover to avoid dropping components in toilet!

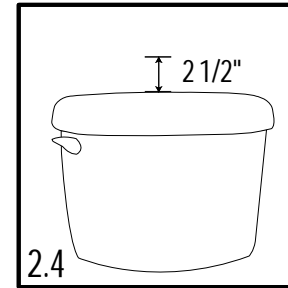

or

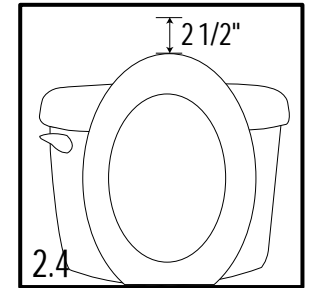

3 Motor Mount Installation

- 3.1 Detach the water fill tube from the overflow pipe and insert the overflow pipe clip (G). This clip will attach to the side of the overflow pipe after the motor installation is complete.
- 3.2 Loosen hex bolt (C) in the motor mount (B).
- 3.3 Slide motor mount (B) onto the overflow pipe (make sure the hex bolt is at the top). The motor mount may require the plastic spacer (E) for a tight fit. The plastic spacer should be placed first on the overflow pipe and then slide the motor mount (B) over the spacer (E).
- 3.4 Align the top of the motor mount (B) to the top of the overflow pipe. Tighten hex bolt (C) by hand.

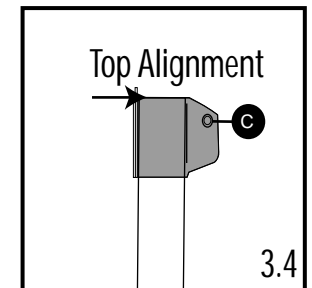
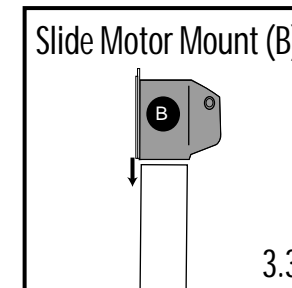
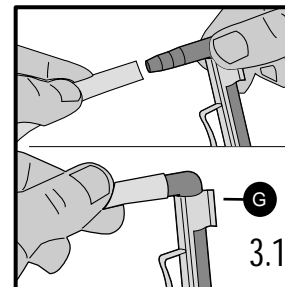

4 Motor Installation

- 4.1 Slide motor (A) on to the motor mount (B). Rotate the two components together to fit in the tank and avoid interfering with existing valve components. Ensure the top of the motor mount (B) is still aligned with the top of the overflow pipe. Keep the electrical sensor cord on the outside of the tank when installing the motor (A).
- 4.2 Rotate the actuator arm (D) on the motor (A) and align above the rubber flapper. Once the arm is aligned, and the motor (A) is not interfering with any of the internal plumbing components, then tighten the hex bolt (C) using the provided Allen wrench (F). Do not over torque.
- 4.3 Determine which of the three holes on the motor arm (D), is most directly aligned above the flapper chain connection. Flip the motor arm (D) up so you can insert the bead chain in the selected hole and lock the chain in the hole slot. Return the arm to the previously aligned position.
- 4.4 Attach chain clip (H) on flapper chain 2" above flapper. Unlock bead chain (H) from motor arm (D) and pull up to take out most of the slack. Lock bead chain in hole slot. Excess chain can be wrapped around motor arm (D) and secured in available hole slot.
- 4.5 Install overflow pipe clip (G) with attached water flow tube into overflow pipe.

NOTE: Leave chain attached to handle, so flush handle can be used for "courtesy flush".

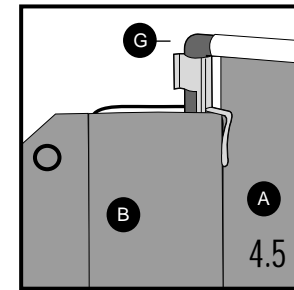
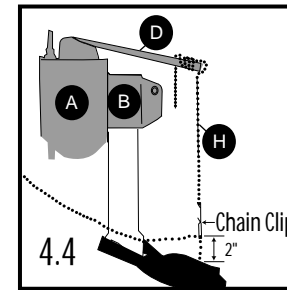
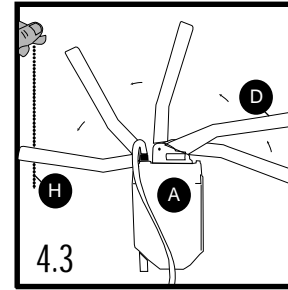
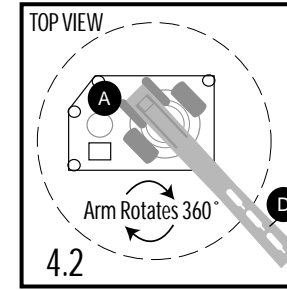
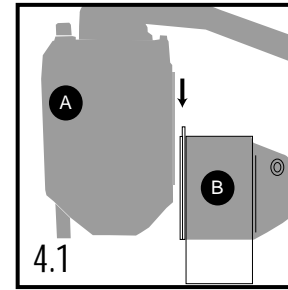

5 Sensor Assembly Installation

- 5.1 Align the sensor so the top of the sensor assembly covers the mark previously made on the wall (Step and Diagram 2.4).
- 5.2 Peel off adhesive backing from sensor assembly and adhere to wall. If you have wallpaper or drywall you may want to use the small screws (N) provided (found in the battery compartment) to mount the sensor assembly (I), instead of using the adhesive.

6 Install Battery Compartment

- 6.1 Check to make sure the sensor cord and motor cord will reach the battery compartment before mounting.
- 6.2 Remove battery compartment cover by unscrewing the two Phillips screws. Inside the battery box (K) there are two large screws and anchors (L). Place the battery compartment (K) in a convenient location under the tank, ensuring easy access.
- 6.3 Secure to wall with screws and anchors, or double-sided tape (R). Note: The battery compartment may be mounted using one screw and anchor with the top slot facilitating easy removal for battery replacement. Make sure the motor cord is placed in the notch at the back edge of the toilet tank (6.3a). If there is not a notch then use the two clear plastic shims (Q)(6.3b).
- 6.4 Plug in the cord from the motor (A) into either one of the receptacles in the battery compartment.
- 6.5 Plug in the sensor assembly cord into the vacant receptacle in the battery compartment.
- 6.6 Install four (4) "D" cell alkaline batteries (P). Noting the battery position marks on the inside of the compartment. Replace cover on battery box.

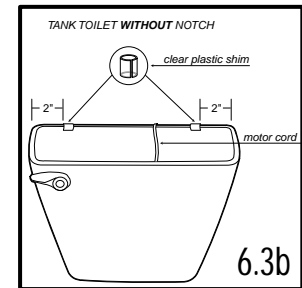
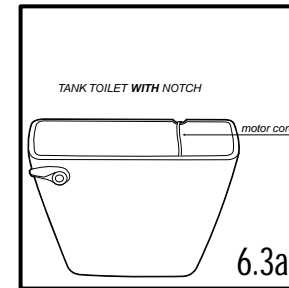

7 Activation

- 7.1 Turn water on and replace toilet tank cover.
- 7.2 Your AutoFlush unit comes preset from the factory. If special circumstances require adjustment of the activation distance, see Appendix A – Adjusting Your AutoFlush. The AutoFlush unit has a 7 minute start-up sequence in which the Object Lock Sensor will activate the User-In-View green L.E.D. continuously as long as a user or object is in view. After the start-up sequence is completed and when the Object Lock Sensor has a user in view, the User-In-View green L.E.D. will flash 3 times once the user is in front of the unit for a minimum of 5 seconds. This prevents needless flushes when someone walks by.

8 Troubleshooting Guide

PROBLEM	CAUSE	SOLUTION TO PROBLEM
Green L.E.D. (light) flashes 3 times when there are no users.	Front of Object Lock Sensor is covered or Object Lock Sensor is set too far out, registering unwanted object.	Remove item covering sensor or adjust Object Lock Sensor activation distance. (See Appendix A - Adjusting the AutoFlush)
Yellow L.E.D. (light) flashes.	Batteries need replacing.	Replace batteries. Use Only Alkaline Batteries.

NOTE: Do not use in-tank cleaners which may damage the motor housing and other tank components.

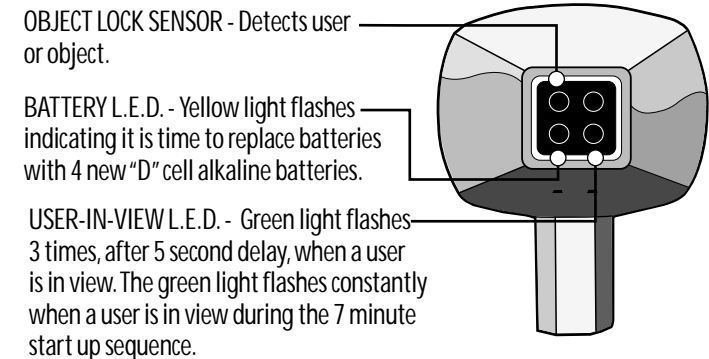

Appendix A- Adjusting Your AutoFlush

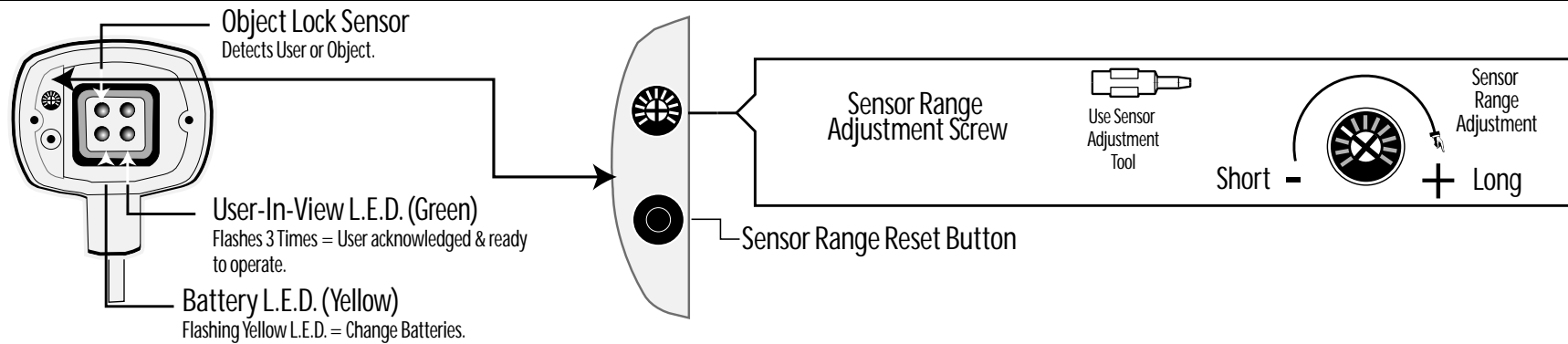

To change activation distance for the Object Lock Sensor:

- 1 Remove the cover of the sensor assembly (I) by taking the sensor cover key (J) and inserting it into the two small holes under the sensor lens. Push in and rotate upward.
- 2 Remove the rubber seal located on the left side of the sensor lens.
- 3 Press sensor range reset button shown in above diagram. Note: the green L.E.D. will flash continuously when it has an object in view for the seven minute reset period. This allows you to select the correct range.
- 4 Stand at desired activation distance.
- 5 Use sensor adjustment tool and turn Sensor Range Adjustment Screw all the way down (counter clockwise) and then turn slowly up (clockwise) until green L.E.D. begins to flash.
- 6 Ensure Object Lock Sensor is not detecting unwanted objects, by stepping out of sensor path and making sure green L.E.D. is not flashing. If sensor locks onto an unwanted object, unit will not flush properly. Shorten activation distance.
- 7 Replace sensor cover.
- 8 After 7 minute start-up sequence, the green L.E.D. will flash only 3 times when a user is in view (after a 5 second delay).

Spanish and French installation instructions are available at www.technicalconcepts.com

Instrucciones de instalacion en Frances y en Español estaran disponibles en la pagina www.technicalconcepts.com

Les instructions pour l'instalation sont disponibles en francais et en espagnol sur notre site web ; www.technicalconcepts.com



World Headquarters:
Serving North & South America
Technical Concepts LLC.
1301 Allanson Road
Mundelein, Illinois 60060 U.S.A.
☎ 847-837-4100
Fax: 1-800-551-5046

European Headquarters:
Serving Europe, Africa & Middle East
Technical Concepts International Ltd.
Pin Green Business Park Eastman Way
Stevenage, Herts SG1 4UH, England
☎ +44 (0)870 568 6824
Fax: +44 (0)1438 311200

Asian Headquarters:
Serving Asia & Pacific
Technical Concepts Asia
51 (B) Lorong Perindustrian Bukit minyak 9
14100 Bukit Mertajam, Penang, Malaysia
☎ (60) 4 508 5008
Fax: (60) 4 508 5001

Toll Free: 1-800-551-5155

Web: www.technicalconcepts.com

Email: info@technicalconcepts.com