

## INSTALLATION INSTRUCTIONS SENSOR OPERATED ELECTRONIC SOAP DISPENSER



### **Model ESD-200**

Deck Mounted  
Plug-in Transformer Powered  
Sensor Operated  
Electronic Soap Dispenser

### **Model ESD-250**

Deck Mounted  
Battery Powered  
Sensor Operated  
Electronic Soap Dispenser

### **For Soap Replenishment use:**

#### **Sloan Part No. ESD-217 (800 ml Bottle)**

Can also be used with TC<sup>®</sup> OneShot<sup>®</sup> Soap Cartridges (TC Stock #401311)

### **To order Replacement Soap Cartridges:**

1-800-440-5556 or 1-503-352-1201  
Or go to our website: [www.airdelights.com](http://www.airdelights.com)

Installation of the Sloan ESD-200 and ESD-250, Sensor Operated Electronic Soap Dispenser makes soap dispensing totally "hands-free" providing the ultimate in sanitary protection and automatic operation. The Electronic Soap Dispenser uses infrared technology to sense the user's presence and dispense an application of hand washing soap. The ESD-200 Soap Dispenser is powered by a plug-in transformer (included). The ESD-250 Soap Dispenser is powered by four "D" cell batteries (included) which eliminates the need to run any electrical lines to the system.

The Sloan ESD-200 and ESD-250, Sensor Operated Electronic Soap Dispenser comes complete with an integral spout and sensor assembly, control module, soap cartridge and all mounting hardware.

The following instructions will serve as a guide when installing the Sloan ESD-200 and ESD-250 Electronic Soap Dispenser. As always, good safety practices and care are recommended when installing your new Soap Dispenser. If further assistance is required, contact Air Delights Customer Service at 1-800-440-5556.

### **LIMITED WARRANTY**

Sloan Valve Company warrants its ESD-200 and ESD-250 Electronic Soap Dispenser to be made of first class materials, free from defects of material or workmanship under normal use and to perform the service for which they are intended in a thoroughly reliable and efficient manner when properly installed and serviced, for a period of three years (1 year for special finishes) from date of purchase. During this period, Sloan Valve Company will, at its option, repair or replace any part or parts which prove to be thus defective if returned to Sloan Valve Company, at customer's cost, and this shall be the sole remedy available under this warranty. No claims will be allowed for labor, transportation or other incidental costs. This warranty extends only to persons or organizations who purchase Sloan Valve Company's products directly from Sloan Valve Company for purpose of resale. This warranty does not cover the life of the batteries (Model ESD-250 only).

**THERE ARE NO WARRANTIES WHICH EXTEND BEYOND THE DESCRIPTION ON THE FACE HEREOF. IN NO EVENT IS SLOAN VALVE COMPANY RESPONSIBLE FOR ANY CONSEQUENTIAL DAMAGES OF ANY MEASURE WHATSOEVER.**

## PRIOR TO INSTALLATION

### New Soap Dispenser Installation:

- Locate position using templates shown in rough-in diagrams (refer to Pages 2 and 5)
- Ensure that dispenser does not interfere with anything above or below the lavatory/counter top area (refer to Page 5)
- Drill a 1" diameter hole in counter top (use template on Page 5)
- Clean area around hole

### Replacing Existing Soap Dispenser:

- Remove old components
- Clean Area
- Ensure hole is 15/16" to 1-1/4" diameter

## SOAP DISPENSER ROUGH-IN (Refer to page 5 for template)

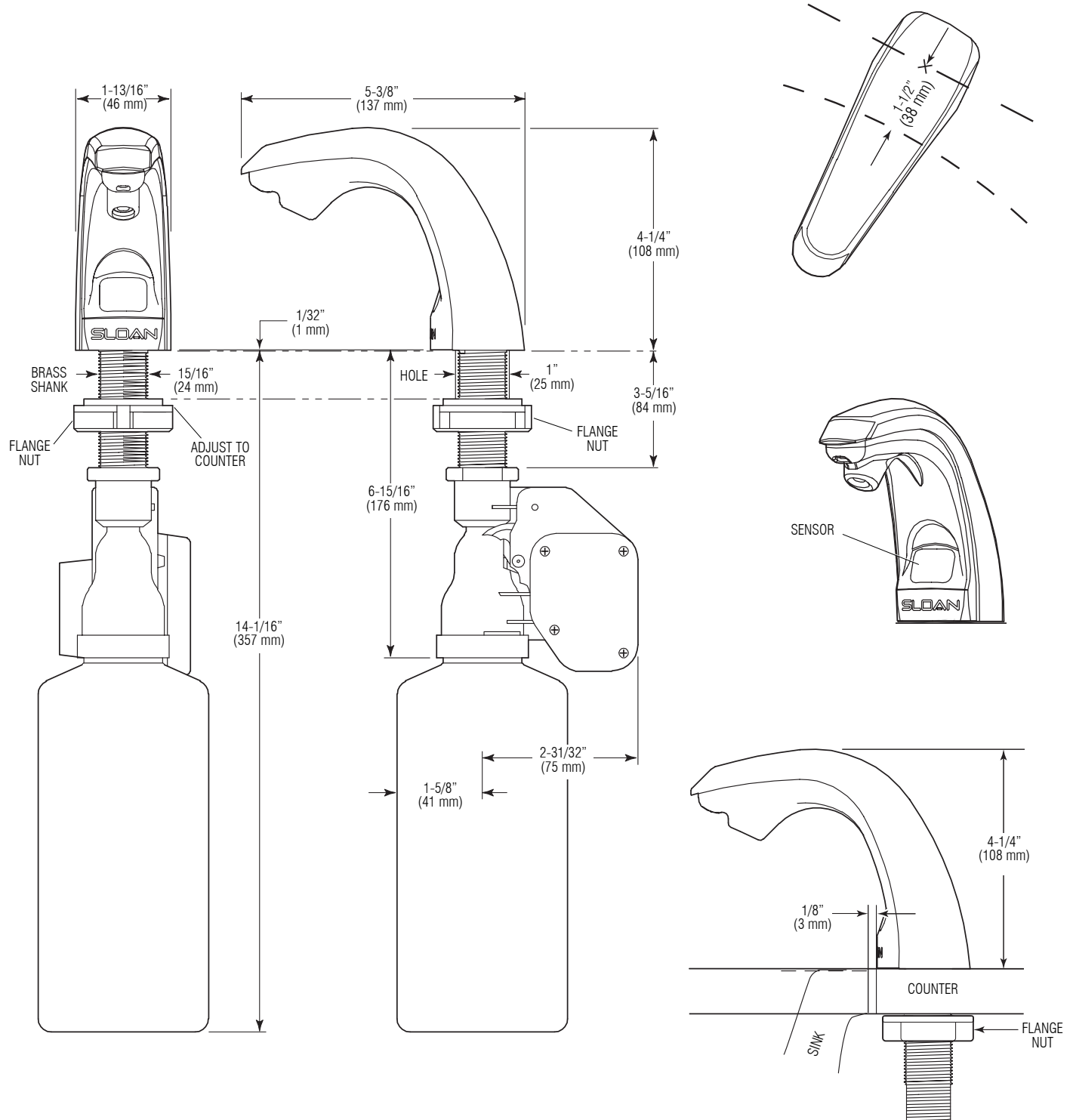

## INSTALLATION

The ESD-200/250 Soap Dispenser oftentimes can be mounted in the left or right hole of a 4" or 8" center-set sink. The ability to do this is contingent upon the width of the faucet spout and accessibility to the unit on the underside of the sink (the Motor and Soap Bottle cannot interfere with the water or drain lines). When such interference above or below the sink occurs, the Soap Dispenser must be installed through the countertop to the side of the sink as shown.

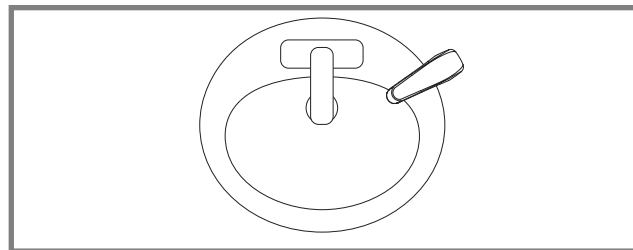

### Models ESD-2085 and ESD-2080 Soap Dispenser and Faucet Combination

When the ESD Soap Dispenser is packaged with a Sloan EBF-85 or ETF-80 Faucet for installation on a 4" center-set sink, a special Trim Plate (ETF-299-A) is supplied. For these models, the Faucet must install on the left side and the Soap Dispenser on the right.

When installing the ESD-2085 or ESD-2080, use these instructions in conjunction with the Installation Instructions packaged with the faucet.

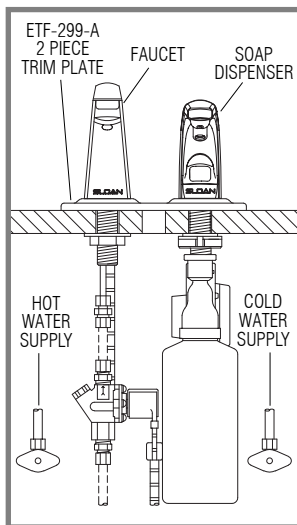

### Step 1 — Install Spout

- A** Slide Rubber Gasket onto Brass Shank making certain that hole in Gasket is positioned over Spring Pin in Base of Spout (where applicable).
- B** Guide Brass Shank and Sensor Cord through hole in counter.
- C** Position Spout to direct soap into sink.
- D** Guide Sensor Cord through Flange Nut. Screw Flange Nut onto Brass Shank and tighten.

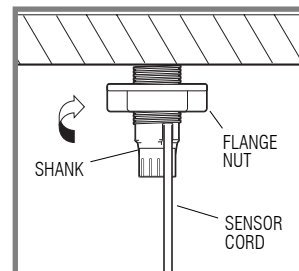
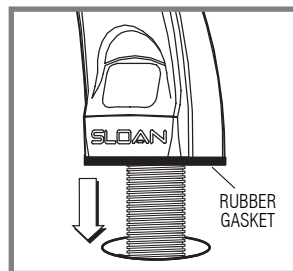

### Step 2 — Attach Motor Assembly

- A** Slide C-clip to the open position.
- B** Place the motor assembly at the bottom of the shank.
- C** Rotate motor housing to avoid lavatory bottom and existing plumbing. Position motor housing so red reset button is accessible.
- D** Push the motor assembly up into place and secure by pushing the C-clip closed.
- E** Plug sensor connector into motor assembly and slide rubber seal into place.

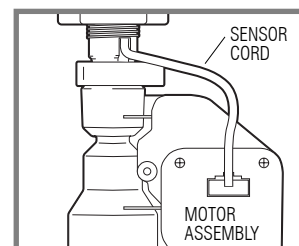
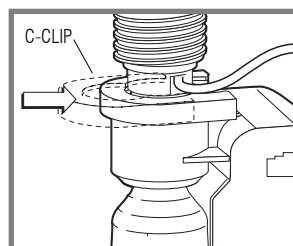
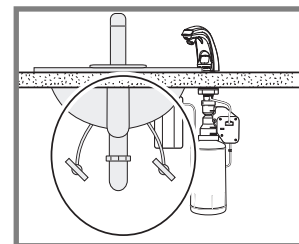
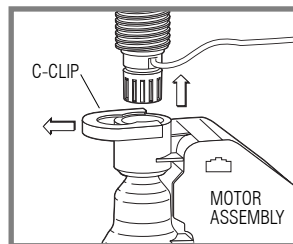

### Step 3 — Attach Battery Pack (Model ESD-250 Only)

- A** Place battery pack in a convenient location ensuring easy access.
- B** Secure to wall with screws and anchors.  
*Note: The battery pack may be mounted using one screw and anchor with the top slot facilitating easy removal for battery replacement. A foam gasket is applied to the back to seal screw holes.*
- C** Install 4 alkaline "D" cell batteries.
- D** Connect the power cord from the battery pack to the cord from the motor assembly, activating the soap dispenser.
- E** Wall clip set may be used to hold the power cord against the wall.

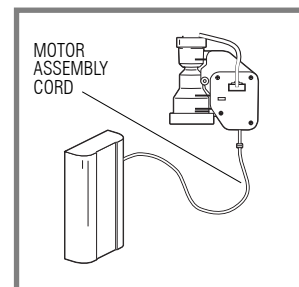
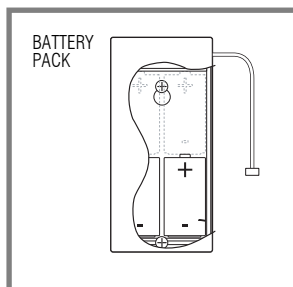

## Step 4 — Connect AC Power (Model ESD-200 Only)

- A Connect the power cord from transformer to the cord from the motor assembly.  
*Note: Transformer supplied with 24" (610 mm) cord.*
- B Plug transformer into 120 VAC wall receptacle, activating the soap dispenser.
- C Wall clip set may be used to hold the power cord against the wall.

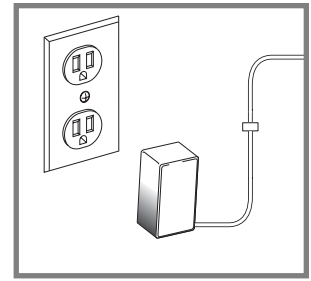
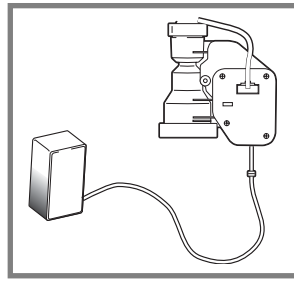

## Step 5 — Install Soap Cartridge

**Important:** DO NOT handle soap refill cartridge by tube. For proper operation, ensure that tubing is not loose or bent.

- A Unlock pump on refill cartridge by twisting counter-clockwise. Actuator will pop-up.
- B Guide refill tube up through bottom of motor assembly.
- C Lock soap refill into place by turning clockwise ¼ turn.
- D Press the refill reset button. This will automatically prime the soap refill bottle and initiate the counting mechanism.

800 ml. refill cartridge dispenses up to 1000 hand washes (supplied).

1600 ml. refill cartridge dispenses up to 2000 hand washes.

When using a 1600 ml. refill cartridge, the dipswitch (located on the Motor behind the black gromet just above the Reset Button) must be in the Down Position.

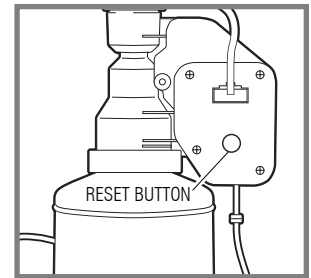
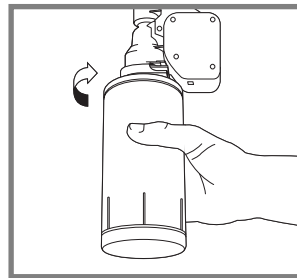
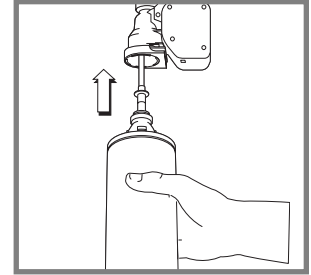
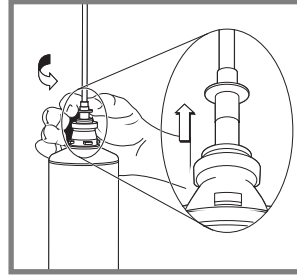

## OPERATION

As the user's hands enter the beam's effective range, the beam is reflected back into the sensor receiver and activates the solenoid valve allowing a single soap application to flow from the spout.

- Flashing red light in the sensor window indicates low refill.
- Flashing yellow light in the sensor window indicates low battery (Model ESD-250 only).

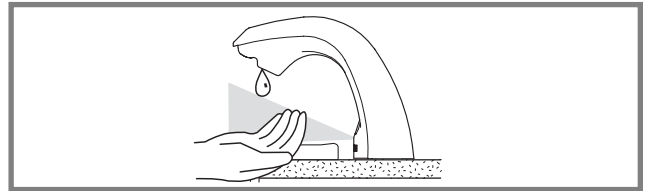

## TROUBLE SHOOTING GUIDE

- I. **Red LED light is flashing.**
  - A. Refill bottle is low. Check the fill level and change as needed.
  - B. Reset button was not pressed after the refill was installed. Press and release reset button.
  - C. If reset button is held down more than a second, the red light will stay on. To turn the red light off, press the reset button quickly and the red light will go off.
- II. **Yellow LED light is flashing (Model ESD-250 only).**
  - A. Batteries are low. Replace with four (4) new "D" cell alkaline batteries.
- III. **How does one keep soap from dispensing while cleaning.**
  - A. Place your finger over the upper right hand or left hand corner of the sensor lens.
- IV. **The dispenser does not activate properly when hand is place under spout.**
  - A. In rest rooms with fluorescent lighting, lighting that may be dying out or not burning at full intensity will cause interference with soap dispenser. Replace fluorescent tube(s) and soap dispenser will then function normally. Cool, white tubes are recommended.
- V. **Dispenser rotates due to users moving the spout.**
  - A. Tighten the existing flange nut on the shaft of the spout under the counter.
  - B. If this problem continues, you can order a second "flange nut" (ESD-620) from Sloan Valve.
- VI. **Soap does not dispense.**
  - A. Check that your power source is plugged in correctly.
  - B. Make sure batteries have been installed properly (Model ESD-250 only).
  - C. Make sure the pump is open on the refill bottle (see Step 5A).
- VII. **Soap doesn't dispense when user "waves" their hands under the spout.**
  - A. Hands must be held "steady" under the spout to work.
- VIII. **Tube pulls out of the refill bottle.**
  - A. The tubes have been "stitched" to prevent their removal, however please ensure that your housekeeping staff does not pick the bottle up or carry it by the tube.

## CARE AND CLEANING OF THE SOAP DISPENSER

Deactivate the soap dispenser by placing your fingers or thumb over the sensor area while you clean. The sensors are located in the upper right and upper left corners of the activation zone.

Once dispenser is cleaned, remove fingers or thumb from the sensor area.

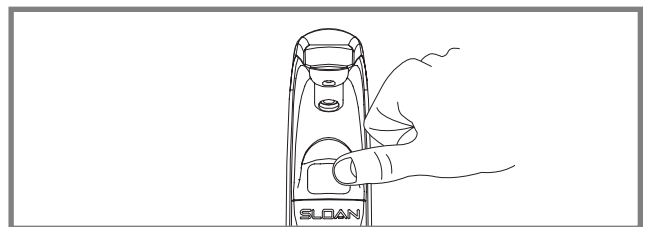

## CARE AND CLEANING OF CHROME AND SPECIAL FINISHES

DO NOT use abrasive or chemical cleaners (including chlorine bleach) to clean spout as they may dull the luster and attack the chrome or special decorative finishes. Use ONLY soap and water, then wipe dry with clean cloth or towel.

While cleaning the bathroom tile, the faucet should be protected from any splattering of cleaner. Acids and cleaning fluids will discolor or remove chrome plating.

## ESD-200 and ESD-250 Soap Dispenser Location Template

### IMPORTANT: READ THIS BEFORE USING TEMPLATE.

If this Installation Instructions was printed from a PDF file to a computer printer, make certain that the template is the correct size before using. Measure to make certain that the 1-1/2" (38 mm) dimension shown on this template is correct. If the dimension measures less than 1-1/2" (38 mm), do one of the following:

- Reprint this template page making certain that all references to "Shrinking oversized pages to paper size" or "Fit to page" are unchecked in the Print window. Also, click the Printer Properties button (if available), and do the same. This template should then print to the proper size.
- Use this template as an example only for Soap Dispenser positioning.

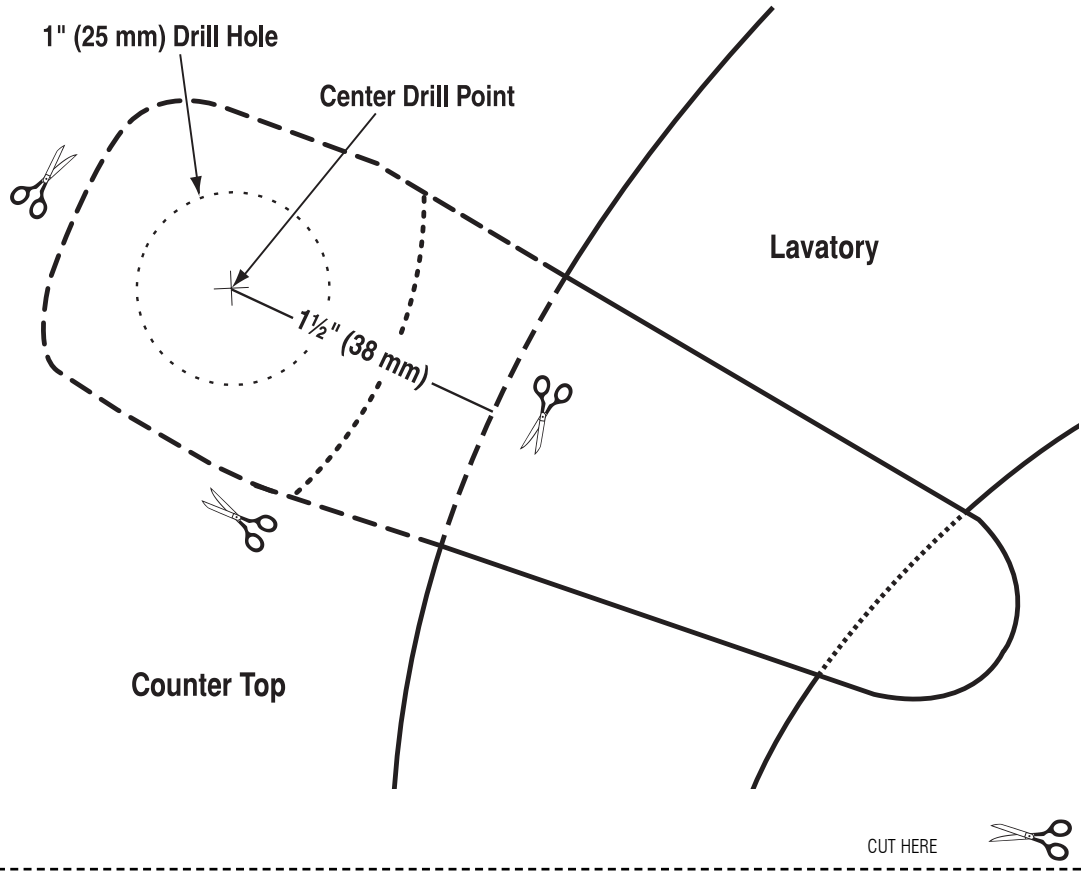

CUT HERE

Soap Dispenser Mounted on Side of Sink

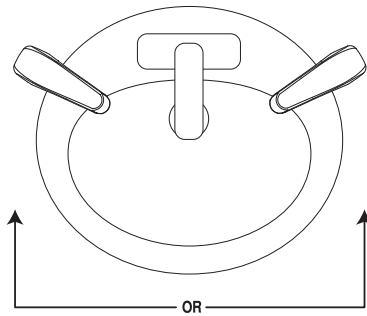

or

Soap Dispenser Shown on a 4" Center-set Sink with an ESD-2080 or ESD-2085 Combination

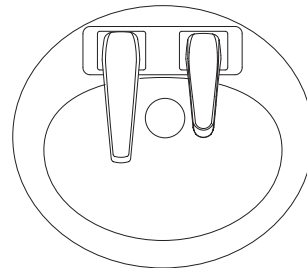

Ensure Soap System does not interfere with sink and plumbing under the counter

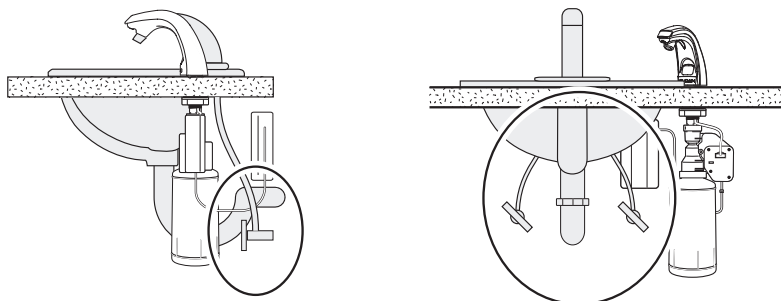

## SOAP REPLACEMENT

When the Soap Bottle is empty, a new Bottle must be used. The Bottle furnished with the unit is not designed to be refilled. Altering the Bottle and refilling it with soap will void the warranty of the product.

### Soap Information

Replace with Sloan Part No. ESD-217 (800 ml Bottle)

Can also be replaced with TC® OneShot® Soap Bottles (TC Stock #401311)

To order Replacement Soap Cartridges:  
1-866-700-CLEAN (1-866-700-2532)

Or go to our website: [www.optimasoap.com](http://www.optimasoap.com)

Refills are also available through your local plumbing or janitorial supply distributor.

### Sloan Lotion Hand Soap with Moisturizers

Rich, luxurious hand soap with special moisturizing ingredients (Glycerin, Aloe Vera and Vitamin E) to help soothe and soften skin. Produces a thick, creamy lather and has a fresh floral scent.

Color: Pearlized Teal

### Warnings

For external use only. See precautions listed below.

### Directions

Wet skin and place a small amount of cleanser on hands. Scrub well, rinse and dry thoroughly.

### Ingredients

DI Water; Sodium Lauryl Sulfate; Lauryl Polyglucose; Cocamidopropyl Betaine; PEG-7 Glyceryl Cocoate; Glycerin; Cocamide DEA; Sodium Laureth Sulfate; Glycol Distearate; Cocamide MEA; Laureth-10; Aloe Barbadosensis Leaf Extract; Fragrance; Glycolic Acid; Tocopherol Acetate; Tetrasodium EDTA; Methylchloroisothiazolinone; Methylisothiazolinone; FD&C Blue 1.

### Other Information

Avoid excessive heat; protect from freezing.

**ATTENTION: Do not handle by tube. For proper operation, ensure that tubing is not loose or bent.**

### PRODUCT PRECAUTIONS

- |  |  |   |
|--|--|---|
| <ul style="list-style-type: none"> <li>• Eye irritant.</li> <li>• Avoid contact with eyes.</li> <li>• Keep out of reach of children.</li> <li>• If in contact with eyes, flush with water for at least 15 minutes. Obtain medical attention if irritation persists.</li> <li>• If ingested, do not induce vomiting. Obtain medical attention immediately.</li> </ul> | <ul style="list-style-type: none"> <li>• Irritant pour les yeux.</li> <li>• Éviter le contact avec les yeux.</li> <li>• Garder hors de la portée des enfants.</li> <li>• En cas de contact avec les yeux, rincer à grande eau pendant 15 minutes. Obtenir de l'attention médicale si l'irritation persiste.</li> <li>• En cas d'ingestion, ne pas tenter de faire vomir. Obtenir de l'attention médicale immédiatement.</li> </ul> | <ul style="list-style-type: none"> <li>• Irritante para los ojos.</li> <li>• Evitar el contacto con los ojos.</li> <li>• Mantener lejos del alcance de los niños.</li> <li>• En caso de contacto con los ojos, enjuagar con mucha agua durante 15 minutos. Si la irritación persiste, obtener atención médica.</li> <li>• En caso de ingestión, no provocar el vómito. Obtener inmediatamente atención médica.</li> </ul> |
|--|--|---|

READ MATERIAL SAFETY DATA SHEET BEFORE USING PRODUCT

LIRE LA FICHE SIGNALÉTIQUE AVANT D'UTILISER CE PRODUIT

LEER LA FICHA DESCRIPTIVA ANTES DE USAR EL PRODUCTO

## PARTS LIST

Item No.	Part No.	Description
1	ESD-216-A	Spout Assembly
2	ESD-218	Mounting Hardware Kit (Includes parts 2A and 2B)
2A	ESD-222	Rubber Gasket
2B	ESD-620	Flange Nut
3	ESD-209-A	Motor Assembly
4	ESD-227	Plug-in Transformer (Model ESD-200)
5	ESD-210	Battery Pack uses 4 "D" cell batteries (included) (Model ESD-250) Screws and Anchors for Battery Compartment Wall Clips for Power Cord
6	ESD-217	Lotion Soap with Moisturizer Refill Cartridge 800 ml (up to 1000 hand washes)
7	ESD-223	"D" Cell Alkaline Batteries (4 required) (Model ESD-250)
8	ETF-299-A	Trim Plate for ESD-2080 and ESD-2085 Combination Soap Dispenser and Faucet

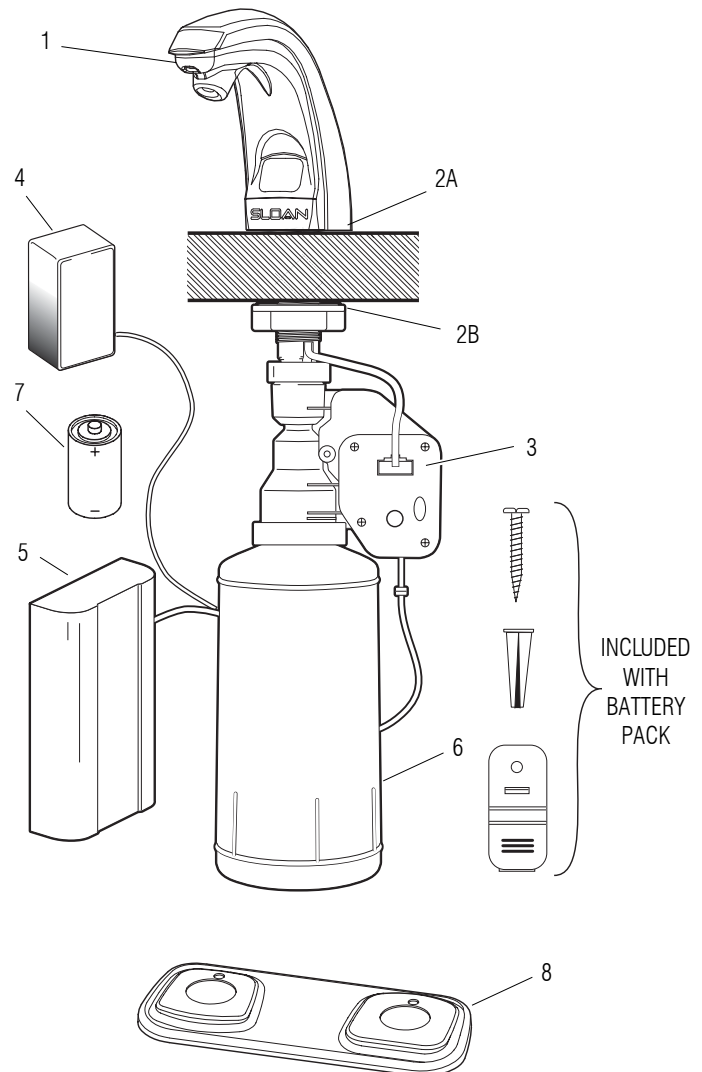

The information contained in this document is subject to change without notice.