

Touch Free Counter Mount System

The superior counter mount handwash experience



Use the dimensions provided to ensure adequate clearance for the new unit.

If this touch-free counter mount system is replacing an existing counter mount dispenser, clean the counter area where the previous dispenser was located. Verify the size of the existing counter hole is 15/16" to 1 1/4" in diameter. If there is no hole in the counter top, it should be drilled to 1" in diameter.

About the Counter Mount System

- Luxurious foam soap
- Three year guarantee
- 1,500 mL refill – more handwashes between refills
- Designed to help eliminate drips
- Sanitary sealed refill and new pump with each bottle
- 20,000 uses from four standard D-size alkaline batteries

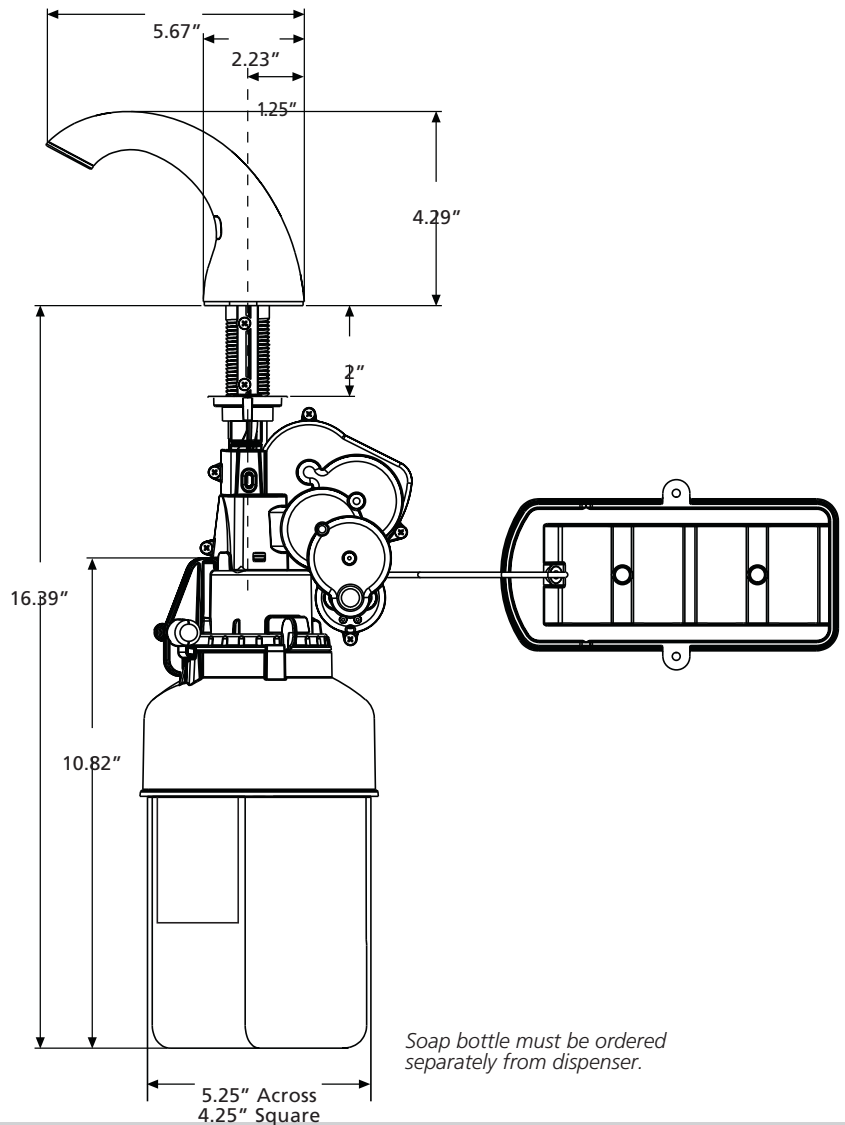

Please note installation diagrams

Improper installation of the Counter Mounted Dispenser could result in breakage.

Dispenser must hang freely underneath the sink.

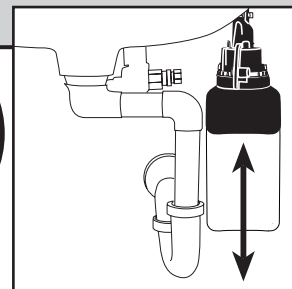
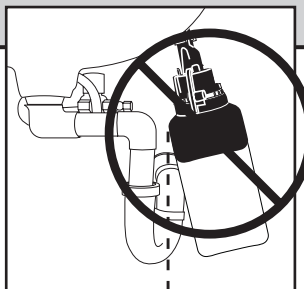

Proper installation allows the unit to vertically hang beneath the sink.