

110 ES-S 111 ES-S

► **Description**

Exposed, Sensor Operated Royal® Model Water Closet Flushometer, for floor mounted or wall hung top spud bowls.

► **Flush Cycle**

- Model 110 ES-S Water Saver (3.5 gpf/13.2 Lpf)
- Model 111 ES-S Low Consumption (1.6 gpf/6.0 Lpf)

► **Specifications**

Quiet, Exposed, Diaphragm Type, Chrome Plated Closet Flushometer for either left or right hand supply with the following features:

- PERMEX™ Synthetic Rubber Diaphragm with Dual Filtered Fixed Bypass
- OPTIMA® EL-1500-L Self-Adaptive Infrared Sensor with Indicator Light
- User friendly three (3) second Flush Delay
- Courtesy Flush™ Override Button
- Non-Hold-Open Integral Solenoid Operator
- Two (2) Chrome Plated Wall Cover Plates (for 2-gang Electrical Box) with Vandal Resistant Screws
- 1" I.P.S. Screwdriver Bak-Chek™ Angle Stop
- Free Spinning Vandal Resistant Stop Cap
- Adjustable Tailpiece
- High Back Pressure Vacuum Breaker Flush Connection with One-Piece Bottom Hex Coupling Nut, Spud Coupling and Flange for 1½" Top Spud
- Sweat Solder Adapter with Cover Tube and Cast Set Screw Wall Flange
- High Copper, Low Zinc Brass Castings for Dezincification Resistance
- Non-Hold-Open Integral Solenoid Operator, Fixed Metering Bypass and No External Volume Adjustment to Ensure Water Conservation
- Flush Accuracy Controlled by CID™ Technology
- Diaphragm, Stop Seat and Vacuum Breaker to be molded from PERMEX™ Rubber Compound for Chloramine Resistance

Valve Body, Cover, Tailpiece and Control Stop shall be in conformance with ASTM Alloy Classification for Semi-Red Brass. Valve shall be in compliance with the applicable sections of ASSE 1037, ANSI/ASME A112.19.6 and Military Specification V-29193. Installation conforms to ADA requirements.

► **Variations**

- TP** Trap Primer
- YG** Extended Bumper on Angle Stop (for seat with cover)
- YO** Bumper on Angle Stop (for open seat without cover)

► **Accessories**

- EL-154** Transformer (120 VAC/24 VAC 50 VA)
- EL-342** Transformer (240 VAC/24 VAC 50 VA)
- EL-485-A** Flushometer Electrical Box Positioning and Support Kit

See Accessories Section and OPTIMA Accessories Section of the Sloan catalog for details on these and other OPTIMA Flushometer variations.



This space for Architect/Engineer approval

Job Name _____ Date _____

Model Specified _____ Quantity _____

Variations Specified _____

Customer/Wholesaler _____

Contractor _____

Architect _____

The information contained in this document is subject to change without notice.



► **Automatic**

Sloan OPTIMA® equipped Flushometers provide the ultimate in sanitary protection and automatic operation. There are no handles to trip or buttons to push. The Flushometer operates by means of an infrared sensor that adapts to its surrounding. Once the user enters the sensor's effective range and then steps away, the Flushometer Solenoid initiates the flushing cycle to flush the fixture.

► **Hygienic**

User makes no physical contact with the Flushometer surface except to initiate the Override Button when required. Helps control the spread of infectious diseases. Twenty-four Hour Sentinel Flush keeps fixture fresh during periods of nonuse.

► **Economical**

Automatic operation provides water usage savings over other flushing devices. Reduces maintenance and operation costs.

► **Practical**

Solid state electronic circuitry assures years of dependable, trouble-free operation. The operational components of the Flushometer are identical to a handle operated Royal® Flushometer, proven by 90 years of experience.

► **Warranty**

3 year (limited)

► **Made in the U.S.A**

110 ES-S 111 ES-S

Description

Exposed, Sensor Operated Royal® Model Water Closet Flushometer, for floor mounted or wall hung top spud bowls.

Flush Cycle

- Model 110 ES-S Water Saver (3.5 gpf/13.2 Lpf)
- Model 111 ES-S Low Consumption (1.6 gpf/6.0 Lpf)

ELECTRICAL SPECIFICATIONS

Control Circuit

Solid State
24 VAC Input
24 VAC Output
8 Second Arming Delay
3 Second Flush Delay
24 Hour Sentinel Flush

Solenoid Operator

24 VAC, 50/60 Hz

Transformer

Sloan Part #EL-154
120 VAC, 50/60 Hz Primary
24 VAC, 50/60 Hz Secondary
Class II, UL Listed, 50 VA.

OPTIMA Sensor Range

Nominal 22" - 42" (559 mm - 1067 mm)
Self-adaptive Window: ± 10" (254 mm)

Sloan Part #EL-342

240 VAC, 50/60 Hz Primary
24 VAC, 50/60 Hz Secondary
Class II, UL Listed, 50 VA.

OPERATION

1. A continuous, invisible light beam is emitted from the OPTIMA Sensor.

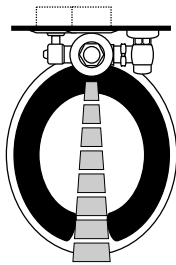

2. As the user enters the beam's effective range (22" to 42") the beam is reflected into the OPTIMA Scanner Window and transformed into a low voltage electrical circuit. Once activated, the Output Circuit continues in a "hold" mode for as long as the user remains within the effective range of the Sensor.

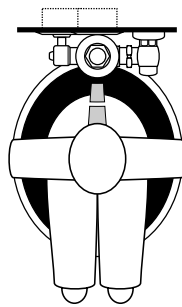

3. When the user steps away from the OPTIMA Sensor, the circuit waits 3 seconds (to prevent false flushing) then initiates an electrical "one-time" signal that operates the Solenoid. This initiates the flushing cycle to flush the fixture. The Circuit then automatically resets and is ready for the next user.

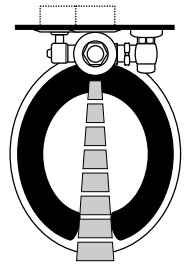

WIRING DIAGRAM

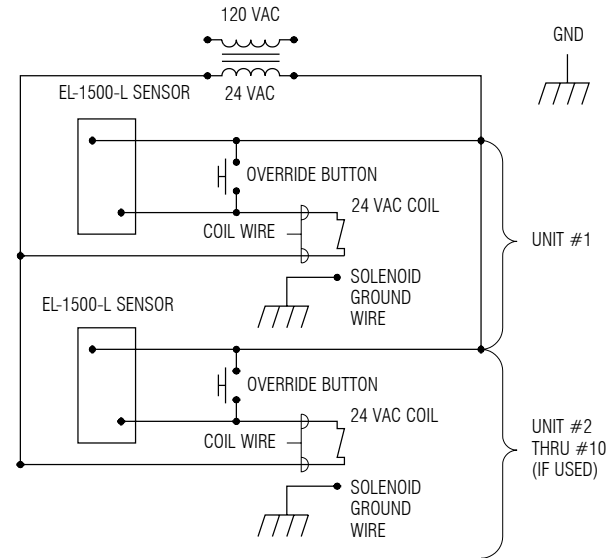

One Transformer serves up to ten (10) OPTIMA Closet/Urinal Flushometers. Specify number of transformers required accordingly.

ELECTRICAL BOX INSTALLATION

SENSOR LOCATION AND POSITIONING IS CRITICAL

Failure to properly position the electrical boxes to the plumbing rough-in will result in improper installation and impair product performance. All tradesmen (plumbers, electricians, tile setters, etc.) involved with the installation of this product must coordinate their work to assure proper product installation. Installation Template furnished with Flushometer.

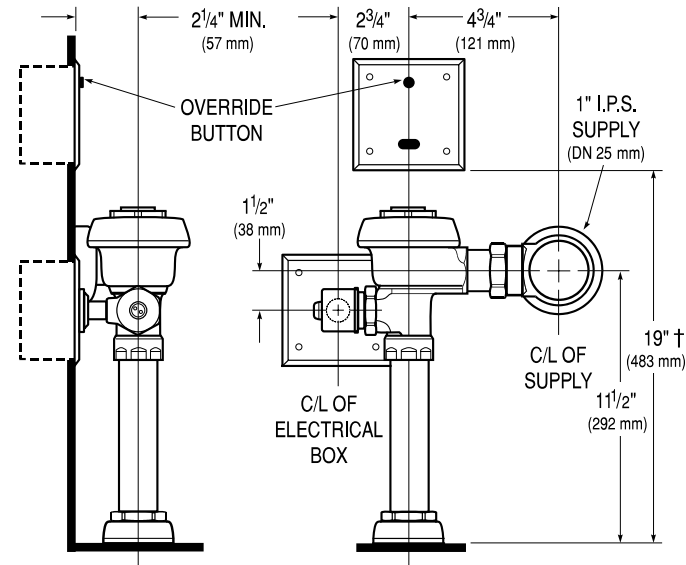

† Position of Sensor Box can be raised or lowered 1" (25 mm) if in conflict with Handicap Grab Bars.

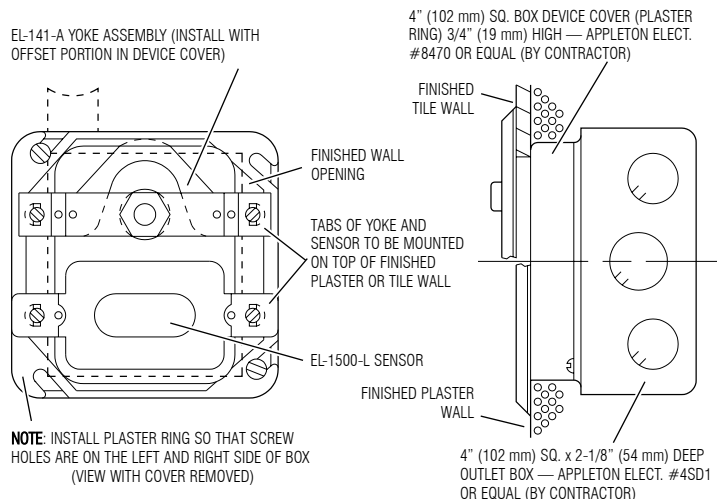

NOTE: INSTALL PLASTER RING SO THAT SCREW HOLES ARE ON THE LEFT AND RIGHT SIDE OF BOX (VIEW WITH COVER REMOVED)

To ensure a perfect rough-in, Sloan recommends the use of the EL-485-A Flushometer Electrical Box Positioning and Support Kit. Specify and order the EL 485-A Kit separately. Consult factory for installation details.

Air Delights 9974 SW Arctic Dr. | Beaverton, Or. 97005

Phone: 1-800-440-5556 | Fax: 1-503-643-8224 | www.airdelights.com | email: customer_service@airdelights.com