

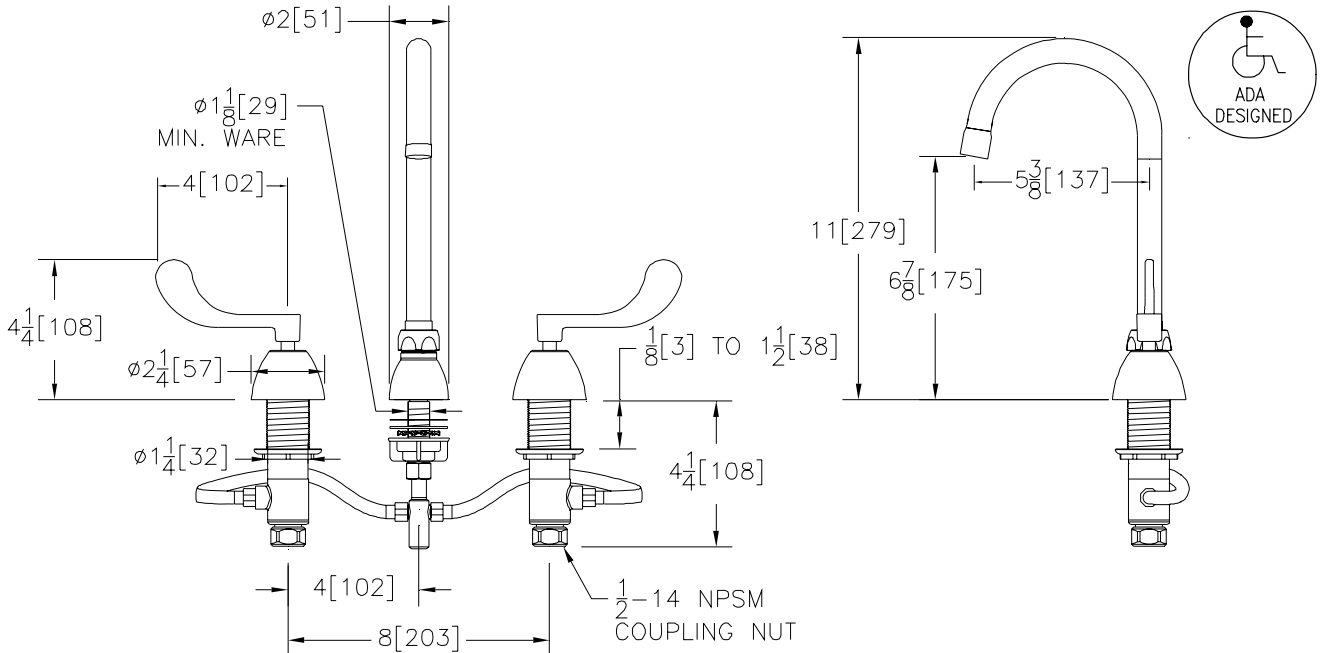

Engineering Specifications: Zurn AquaSpec® Z831B4

Polished chrome-plated widespread with adjustable centers from 6" [152mm] to 20" [508mm], a 5-3/8" [137mm] centerline rigid or swing gooseneck spout and quarter turn ceramic disc cartridges. Unit is furnished with a 2.2 GPM [8.3 L] pressure compensating aerator (complying with ANSI A112.18.1 Standard for flow), 4" [102mm] vandal-resistant color-coded metal wrist blade handles, mounting hardware and 1/2" NPSM coupling nuts for standard lavatory risers. Widespread accommodates installations up to 1-1/2" [38mm] thick.



Note: All dimensions are for reference only. Do not use for pre-plumbing

OPTIONAL ACCESSORIES

Suffix	Description
___ -CWO	Cold Water Only
___ -FC	2.0 GPM [7.6 L] Laminar Flow Control in Base of Spout
___ -G	1-1/4" [32mm] Grid Strainer Drain
___ -GH	1-1/4" [32mm] Offset Handicap Grid Drain
___ -HCT	Hot/Cold Text Indexes
___ -HS	Hose and Spray
___ -ICT	Inter-connecting Copper Supply Tubes for 8" In-line Centers
___ -P	1-1/4" [32mm] Pop-up Drain
___ -PT	1-1/4" [32mm] Cast Brass P-Trap with 7-1/2" [191mm] Long 17-Gauge Wall Bend
___ -TW	Third Waterway
___ -2F	2.2 GPM [8.3 L] Vandal-Resistant Pressure Compensating Female Aerator
___ -3F	0.5 GPM [1.9 L] Vandal-Resistant Pressure Compensating Female Aerator
___ -4F	2.2 GPM [8.3 L] Vandal-Resistant Pressure Compensating Female Laminar Flow
___ -5F	2.0 GPM [7.6 L] Female Spray Outlet
___ -7F	1.0 GPM [3.8 L] Pressure Compensating Female Spray Outlet
___ -16F	1.0 GPM [3.8 L] Vandal-Resistant Pressure Compensating Female Spray Outlet
___ -17F	1.5 GPM [5.7 L] Vandal-Resistant Pressure Compensating Female Aerator
___ -18F	1.5 GPM [5.7 L] Vandal-Resistant Pressure Compensating Female Laminar Flow

AIR DELIGHTS, INC. ♦ COMMERCIAL BRASS OPERATION ♦ 9974 SW ARCTIC DR. ♦ BEAVERTON, OR. 97005

Phone: 1-800-440-5556 ♦ Fax: 1-503-643-8224 ♦ World Wide Web: www.airdelights.com

In Canada: ZURN INDUSTRIES LIMITED ♦ 3544 Nashua Drive ♦ Mississauga, Ontario L4V1L2 ♦ Phone: 503/352-1201 Fax: 503/643-8224