

For Non-Health Hazard Applications

Job Name _____ Contractor _____
 Job Location _____ Approval _____
 Engineer _____ Contractor's P.O. No. _____
 Approval _____ Representative _____

Series 709

Double Check Valve Assemblies

Sizes: 2½" – 10" (65 – 250mm)

Series 709 Double Check Valve Assemblies are designed to prevent the reverse flow of polluted water from entering into the potable water system. This series can be applied, where approved by the local authority having jurisdiction, on non-health hazard installations. Series 709 features a modular check design concept to facilitate easy maintenance. Check with local jurisdictional authority as to installation requirements.

Features

- Replaceable bronze seats
- Maximum flow at low pressure drop
- Design simplicity for easy maintenance
- No special tools required for servicing
- Captured spring assemblies for safety
- Approved for vertical flow up installation

Models

Suffix:

NRS – non-rising stem resilient seated gate valves

OSY – UL/FM outside stem and yoke resilient seated gate valves

S-FDA – FDA epoxy coated strainer

BB – bronze body - 2½" – 3" (64 – 76mm)

QT – quarter-turn ball valves

QT-FDA – FDA epoxy coated ball valve shutoffs

LF – without shutoff valves

Specifications

A Double Check Valve Assembly shall be installed at referenced cross-connections to prevent the backflow of polluted water into the potable water supply. The cross-connections shall be determined by local inspection authority for use where a high hazard situation does not exist. Valve shall feature modular check assemblies with center stem guiding. Each check module shall have a captured spring and be accessible through a bolted cover plate. Seats shall be replaceable without special tools. It shall be a complete assembly including tight-closing resilient seated shutoff valves, test cocks, and a strainer is recommended. The assembly shall meet the requirements of ASSE No. 1015; AWWA C510-92; CSA B64.5 and UL Classified File No. EX3185. Approved by the Foundation for Cross-Connection Control and Hydraulic Research at the University of Southern California. Assembly shall be a Watts Regulator Company Series 709.

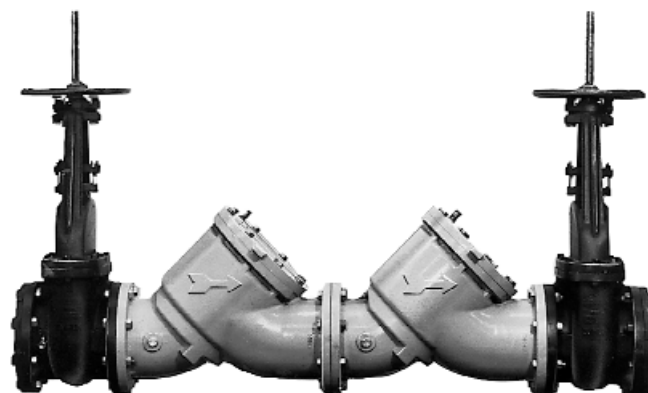

709 OSY

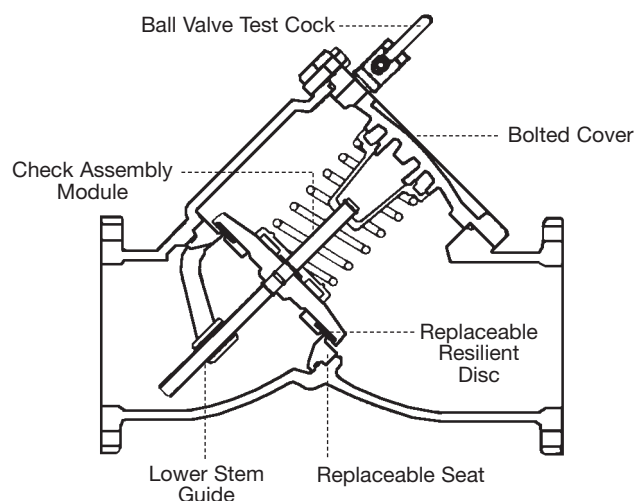

Check Assembly Module

Series 709 features a modular design concept which facilitates complete maintenance and assembly by retaining the spring load. Also, the first and second check module are identical and can be interchanged.

**IMPORTANT: INQUIRE WITH GOVERNING AUTHORITIES
FOR LOCAL INSTALLATION REQUIREMENTS**

Now Available
WattsBox Insulated Enclosures.

For more information, send for literature ES-WB.

Watts product specifications in U.S. customary units and metric are approximate and are provided for reference only. For precise measurements, please contact Watts Technical Service. Watts reserves the right to change or modify product design, construction, specifications, or materials without prior notice and without incurring any obligation to make such changes and modifications on Watts products previously or subsequently sold.

WATTS®

Materials

Check Valve Bodies: Epoxy coated cast iron

Seats: Bronze

Pressure – Temperature

Temperatures Range: 33°F – 110°F (0.5°C – 43°C) continuous,
140°F (60°C) intermittent

Maximum Working Pressure: 175psi (12.1 bar)

Standards

AWWA C510-92

IAPMO PA 31

USC Manual for Cross-Connection Control, 8th Edition

Approvals



Approved by the Foundation for Cross-Connection Control and Hydraulic Research at the University of Southern California. Sizes 4" – 10" (100 – 250mm) approved horizontal and vertical "flow up". Size 2½" and 3" (65 – 80mm) approved horizontal only.

Factory Mutual approved 4" – 10" (80 – 250mm) vertical "flow up" with OSY gate valves only.

Note: Model "S" not listed

Dimensions – Weights

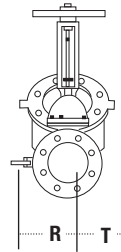
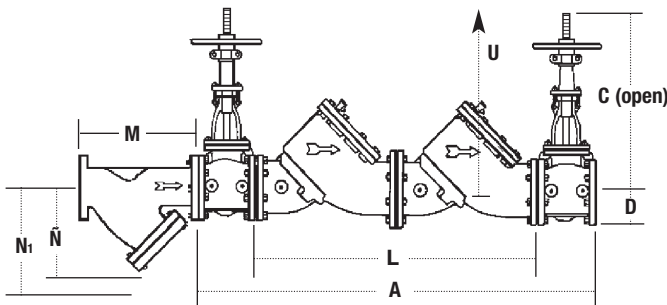

SIZE (DN)		DIMENSIONS															
in.	mm	A		C (OSY)		C (NRS)		D		L		U*		M		N	
		in.	mm	in.	mm	in.	mm	in.	mm	in.	mm	in.	mm	in.	mm	in.	mm
2½	65	39¾	1000	16¾	416	9¾	238	3½	89	24⅞	613	11	279	10	254	6½	165
3	80	40¾	1025	18⅞	479	10¼	260	3¾	95	24⅞	613	14	356	10⅞	257	7	178
4	100	52¾	1330	22¾	578	12¾	310	4½	114	34⅞	867	14	356	12⅞	308	8¼	210
6	150	62¾	1597	30⅞	765	16	406	5½	140	41⅞	1057	16	406	18½	470	13½	343
8	200	75	1905	37¾	959	19 ¹⁵ / ₁₆	506	6½	165	52	1321	21	533	21⅞	549	15½	394
10	250	90	2286	45¾	1162	23 ¹³ / ₁₆	605	8	203	64	1626	25	635	26	660	18½	470

SIZE (DN)		DIMENSIONS								WEIGHT				STRAINER			
in.	mm	N1†		R		R❖		T		NRS		OSY		QT		Weight	
		in.	mm	in.	mm	in.	mm	in.	mm	lbs.	kgs.	lbs.	kgs.	lbs.	kgs.	lbs.	kgs.
2½	65	10	254	4	102	16	406	3	76	167	76	170	77	154	70	28	13
3	80	10	254	5	127	16	406	3	76	167	76	170	77	162	73	34	15
4	100	12	305	6	152	19¾	502	6	152	368	167	383	174	275	125	60	27
6	150	20	508	11	279	26	660	7½	191	627	284	707	321	611	277	122	55
8	200	22¾	578	11¼	286	11¼	286	9	229	1201	545	1307	593	1419	644	247	112
10	250	28	711	12½	318	12½	318	10¼	260	2003	909	2073	940	2466	1119	370	168

† - Dimension required for screen removal. ❖Quarter-turn (QT) valve dimensions.

*Service clearance for check assembly from center.

Capacity

*Typical maximum system flow rate (7.5 feet/sec.) **UL rated flow

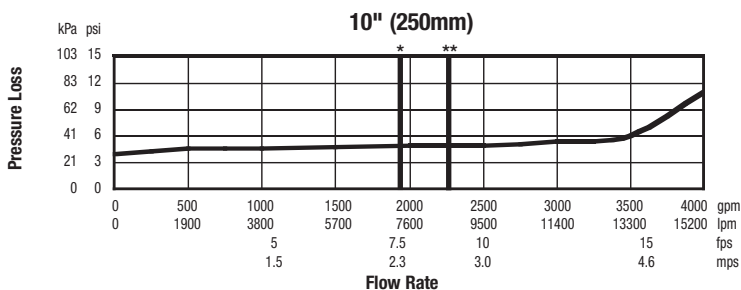
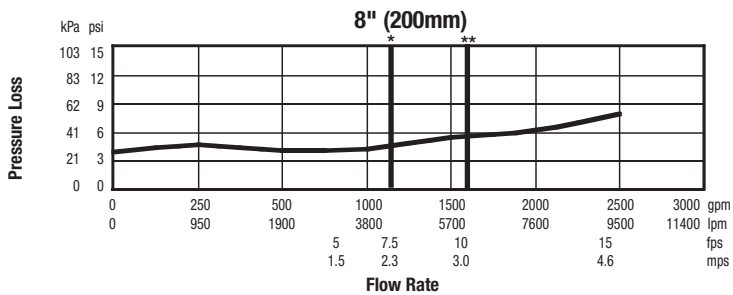
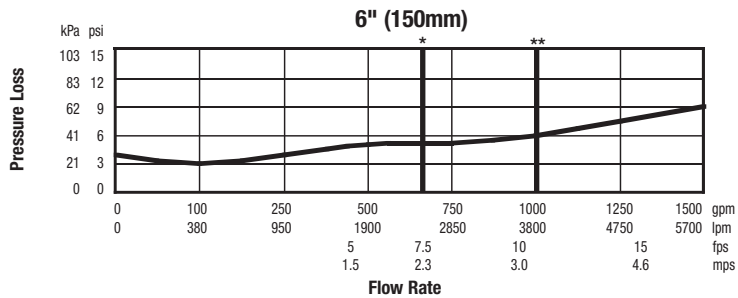
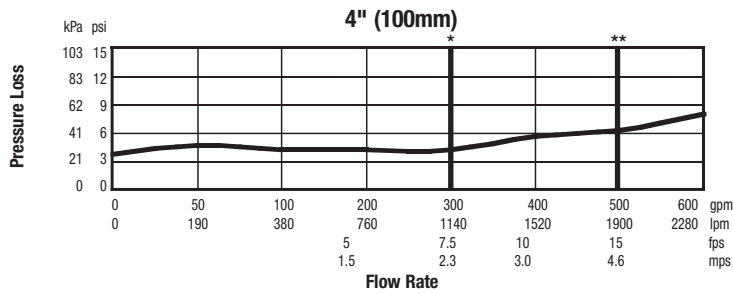
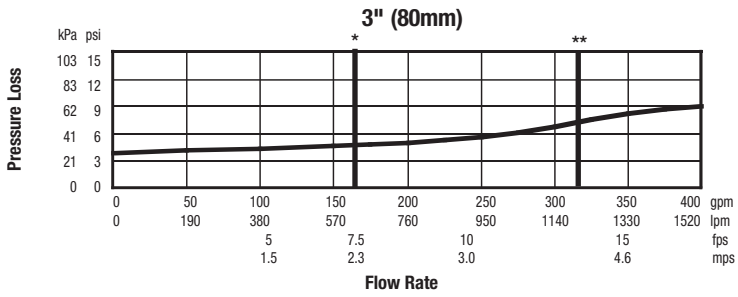
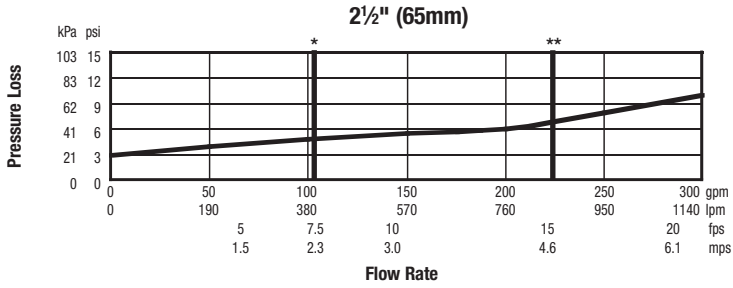



A Watts Water Technologies Company

ES-709L 0639



USA: 815 Chestnut St., No. Andover, MA 01845-6098; www.watts.com
Canada: 5435 North Service Rd., Burlington, ONT. L7L 5H7; www.wattscanada.ca

© 2009 Watts