



## FOR USE WITH SLOAN'S G2 OPTIMA PLUS<sup>®</sup> FLUSHOMETER INTRODUCED MAY, 2003

The Sloan Valve Company introduced its OPTIMA *Plus* Battery Operated Sensor Flushometer in 1992 revolutionizing the flushing of water closets and urinals. In both new construction and retrofit applications the use of the OPTIMA *Plus* has become the standard method for many facilities to improve restroom hygiene and ensure handicap accessibility compliance.

The Sloan G2 OPTIMA *Plus* Automatic Battery Powered Flushometer relies on an Infrared Sensor to detect a user and activate a flushing cycle. No physical contact with the Flushometer surface is necessary, assuring sanitary protection. G2 OPTIMA *Plus* Flushometers are ADA compliant devices.

In May, 2003 Sloan introduced the G2 OPTIMA *Plus*<sup>®</sup>.



**ORIGINAL  
OPTIMA PLUS  
FLUSHOMETER  
AND REGAL PRO<sup>®</sup>  
OPTIMA PLUS**



**G2<sup>®</sup> OPTIMA PLUS  
FLUSHOMETER**

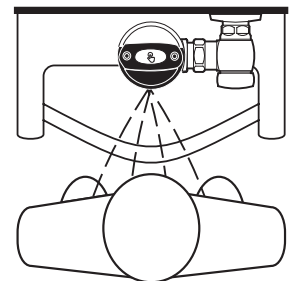
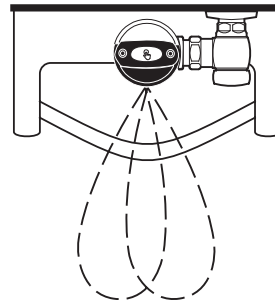

The G2 OPTIMA *Plus* builds on the success of the original product and offers many technological advancements to further improve on performance and reliability expected of sensor operated plumbing. In addition to a new aesthetic design, the G2 OPTIMA *Plus* features a new state-of-the-art electronic and optical package and a unique Solenoid Operator that keeps the moving components of the Solenoid completely isolated from the water supply. This ensures long life and low maintenance regardless of local water condition.

The G2 OPTIMA *Plus* replaces the original OPTIMA *Plus* product, which was phased out of production in mid 2003.

The Flushometer is triggered by means of an active Infrared Sensor. The Optima *Plus* Sensor emits a continuous invisible Light Beam. When a user enters the Beam's effective range, the Beam is reflected into the Optima *Plus* Scanner Window. The user is now detected. After the user moves out of the effective range of the Sensor, a signal is sent to the Flushometer Solenoid and, after appropriate arming and/or flush delays, the flush cycle is initiated.

**Use this Maintenance & Repair Guide for G2 OPTIMA Plus Valves only.**

**For older OPTIMA Plus Valves (produced from 1992 - 2003) and Regal Pro Optima Plus Valves use Maintenance and Repair Guide #0816193.**

**If further assistance is required, please contact the Sloan Valve Company Installation Engineering Department at:**

**Phone: 1-888-SLOAN-14 (1-888-756-2614)**

**Email: [productsupport@sloanvalve.com](mailto:productsupport@sloanvalve.com)**

### LIMITED WARRANTY

Sloan Valve Company warrants its Flushometer Products to be made of first class materials, free from defects of material or workmanship under normal use and to perform the service for which they are intended in a thoroughly reliable and efficient manner when properly installed and serviced, for a period of five years (one year for special finishes) from date of purchase. During this period, Sloan Valve Company will, at its option, repair or replace any part or parts which prove to be thus defective if returned to Sloan Valve Company, at customer's cost, and this shall be the sole remedy available under this warranty. No claims will be allowed for labor, transportation or other incidental costs. This warranty extends only to persons or organizations who purchase Sloan Valve Company's products directly from Sloan Valve Company for purpose of resale.

**THERE ARE NO WARRANTIES WHICH EXTEND BEYOND THE DESCRIPTION ON THE FACE HEREOF. IN NO EVENT IS SLOAN VALVE COMPANY RESPONSIBLE FOR ANY CONSEQUENTIAL DAMAGES OF ANY MEASURE WHATSOEVER.**



**SENSOR OPERATED FLUSHOMETERS**

**SENSOR MODULE COMPONENT PARTS**

Item No.	Code No.	Part No.	Description
1.	0325160	EBV-138-A	G2 Cover/Ring/Sensor Assembly — Water Closet
	0325161	EBV-139-A	G2 Cover/Ring/Sensor Assembly — Urinal
	0325166	EBV-149-A	G2 Cover/Ring/Sensor Assembly — Water Closet w/ Zurn Ring
	0325167	EBV-150-A	G2 Cover/Ring/Sensor Assembly — Urinal w/ Zurn Ring
2.	0325168	EBV-142-A	Cover Assembly
3.	0325172	EBV-130-A	Override Button Assembly (includes screws & hex wrench)
	0325170	EBV-132-A	Screws (2) and Hex Wrench Only
4.	0325169	EBV-131	Lens Window Cover
5.	0325804	EBV-14	Locking Ring
	3325524	EBV-31-A	Locking Ring — for Zurn Valves
6.	3325450	EBV-129-A-C	G2 Electronic Module — Water Closet
	3325451	EBV-129-A-U	G2 Electronic Module — Urinal
7.	0325171	EBV-134	Cover Rest Plate
8.	3325456	EBV-145-A	G2 Inside Cover Assembly (includes solenoid)
9.	3325453	EBV-136-A	Isolated Solenoid (For G2 Modules only)
10.	SEE CHART		Flex Tube Diaphragm Kit

**Accessories**

11.	0325107	EBV-91	Trimpot Adjustment Screwdriver
12.	0325823	EBV-22	Strap Wrench
13.	0325159	EBV-137	7/64" Hex Wrench

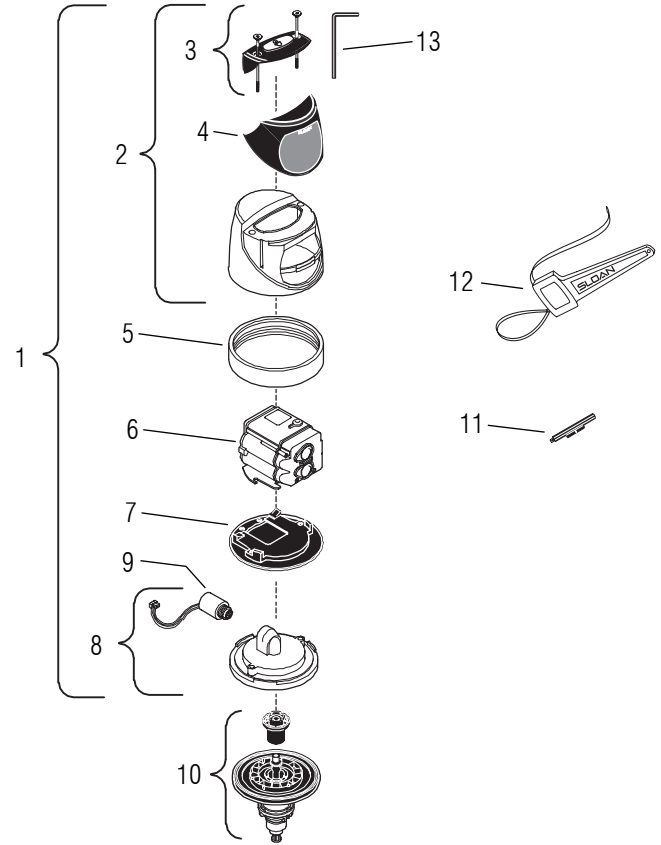

**FLEX TUBE DIAPHRAGM INSIDE PARTS KITS**

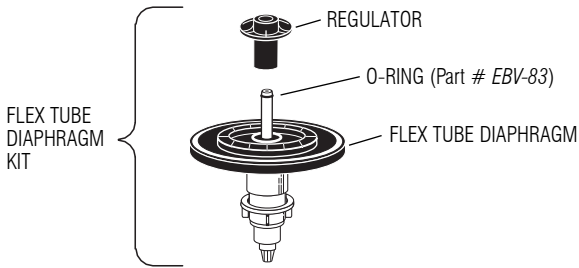

5325056 EBV-83 O-ring — 6 per package

FLEX TUBE DIAPHRAGM KIT †		APPLICATION	REGULATOR COLOR ◆
EBV-1023-A	3325003	URINAL-0.5 gpf/1.9 Lpf	GREEN
EBV-1022-A	3325000	URINAL-1.0 gpf/3.8 Lpf ‡	GREEN
EBV-1022-A	3325000	URINAL-1.5 gpf/5.7 Lpf	BLACK
EBV-1020-A	3325001	URINAL-3.5 gpf/13.2 Lpf	WHITE
EBV-1020-A	3325001	CLOSET-1.6 gpf/6.0 Lpf	GREEN
EBV-1021-A	3325014	CLOSET-2.4 gpf/9.0 Lpf	BLUE
EBV-1020-A	3325001	CLOSET-3.5 gpf/13.2 Lpf	WHITE
EBV-1020-A	3325001	CLOSET-4.5 gpf/17.0 Lpf §	WHITE

† The EBV-1020-A and EBV-1022-A Kits are supplied with multiple Regulators.  
 ‡ A 0.5 gpf (1.9 Lpf) Urinal kit can be converted to a 1.0 gpf (3.8 Lpf) by cutting and removing the smooth A-164 Flow Ring from the Guide.  
 § For a 4.5 gpf (17 Lpf) Water Closet flush use the EBV-1020-A Kit with the White Regulator, and cut and remove the A-164 Flow Ring from the Guide.  
 ◆ Color of Regulator to be used with Flex Tube Diaphragm to obtain the listed flush volume.

**REGULATORS**

The flush volume of the Flex Tube Diaphragm Kit is control by the Regulator. Regulators are identified by color. Some Flex Tube Diaphragm Kits are supplied with multiple Regulators. The installer must make sure the proper Regulator is used when installing the Flex Tube Diaphragm Kit.

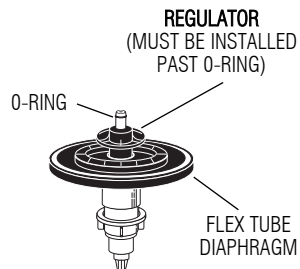

**REGULATOR (Sold 6 per package)**

FLUSH VOLUME AND FIXTURE	REGULATOR COLOR	PART NO.	CODE NO
URINAL-0.5 gpf/1.9 Lpf	GREEN	EBV-95	5325122
URINAL-1.0 gpf/3.8 Lpf	GREEN	EBV-95	5325122
URINAL-1.5 gpf/5.7 Lpf	BLACK	EBV-102-2	5325129
URINAL-3.5 gpf/13.2 Lpf	WHITE	EBV-102-1	5325130
CLOSET-1.6 gpf/6.0 Lpf	GREEN	EBV-95	5325122
CLOSET-3.5 gpf/13.2 Lpf	WHITE	EBV-102-1	5325130
CLOSET-2.4 gpf/9.0 Lpf	BLUE	EBV-101	5325128

The EBV-1020-A and EBV-1022-A Kits are supplied with multiple Flush Volume Regulators. The Installer must use the correct Regulator when installing the kit.

**VALVE COMPONENT PARTS**

Item No.	Code No.	Part No.	Description
14.	3323182	V-651-A	Vacuum Breaker Repair Kit
15.	0393004	V-600-A	3/4" x 9" CP Vacuum Breaker
	0393006	V-600-A	1 1/4" x 9" CP Vacuum Breaker
	0393007	V-600-A	1 1/2" x 9" CP Vacuum Breaker
16.	0306125	F-5-A	3/4" CP Spud Coupling
	0306140	F-5-A	1 1/4" CP Spud Coupling
	0306146	F-5-A	1 1/2" CP Spud Coupling
17.	0308676	H-550	CP Stop Coupling
18.	0308801	H-551-A	CP Adjustable Tailpiece 2-1/16" long
19.	5308696	H-553	O-ring — 24 per package
20.	3308386	H-700-A	1" Screwdriver Bak-Chek® Stop CP — complete
	3308384	H-700-A	3/4" Screwdriver Bak-Chek® Stop CP — complete
21.	3308853	H-541-A	Control Stop Repair Kit †
	3308856	H-543-A	Control Stop Repair Kit ‡
22.	0308612	H-622	CP Bonnet †
	0308843	H-577	CP Bonnet ‡
23.	3308791	H-1010-A	Vandal Resistant Control Stop Cap Assembly †
	3308790	H-1009-A	Vandal Resistant Control Stop Cap Assembly ‡
24.	3325816	EBV-1019-A	3/4" Decorative Stop Cap
	3308866	H-574	1" Decorative Stop Cap
25.	3325815	EBV-1018-A	Handle Cap — Decorative
26.	3325814	EBV-1017-A	Handle Cap — Metal

† For use w/H-700-A 1" & 3/4" and H-600-A 1" Screwdriver Bak-Chek® Control Stops.  
 ‡ For use w/H-600-A 3/4" Screwdriver Bak-Chek® Control Stops.

**Battery Replacement**

When G2 Optima Plus has approximately 4,000 flushes left, the same Red Light that appears at start-up will flash four (4) times quickly whenever an object is detected. When this occurs, we recommend changing the batteries as follows:

When required, replace Batteries with four (4) Alkaline Type AA Batteries.

**Note:** Water does not have to be turned off to replace Batteries.

Loosen the two (2) Screws on top of unit. Remove the complete Cover Assembly. Lift the Sensor Module from its Plate. Unplug the Electrical Connector from Battery Compartment Cover. Loosen the Retaining Screw on Battery Compartment Cover and remove Battery Compartment Cover. Install four (4) Alkaline Type AA Batteries exactly as illustrated at right.

Install Battery Compartment Cover and secure with Retaining Screw. Make certain that Battery Compartment Cover is fully compressed against Gasket to provide a seal; Do Not overtighten. Plug the Electrical Connector into the Battery Compartment Cover. Reinstall the Sensor Module onto the Plate. Reinstall the complete Cover Assembly onto the Plate. Tighten the two (2) Screws on top of the unit.

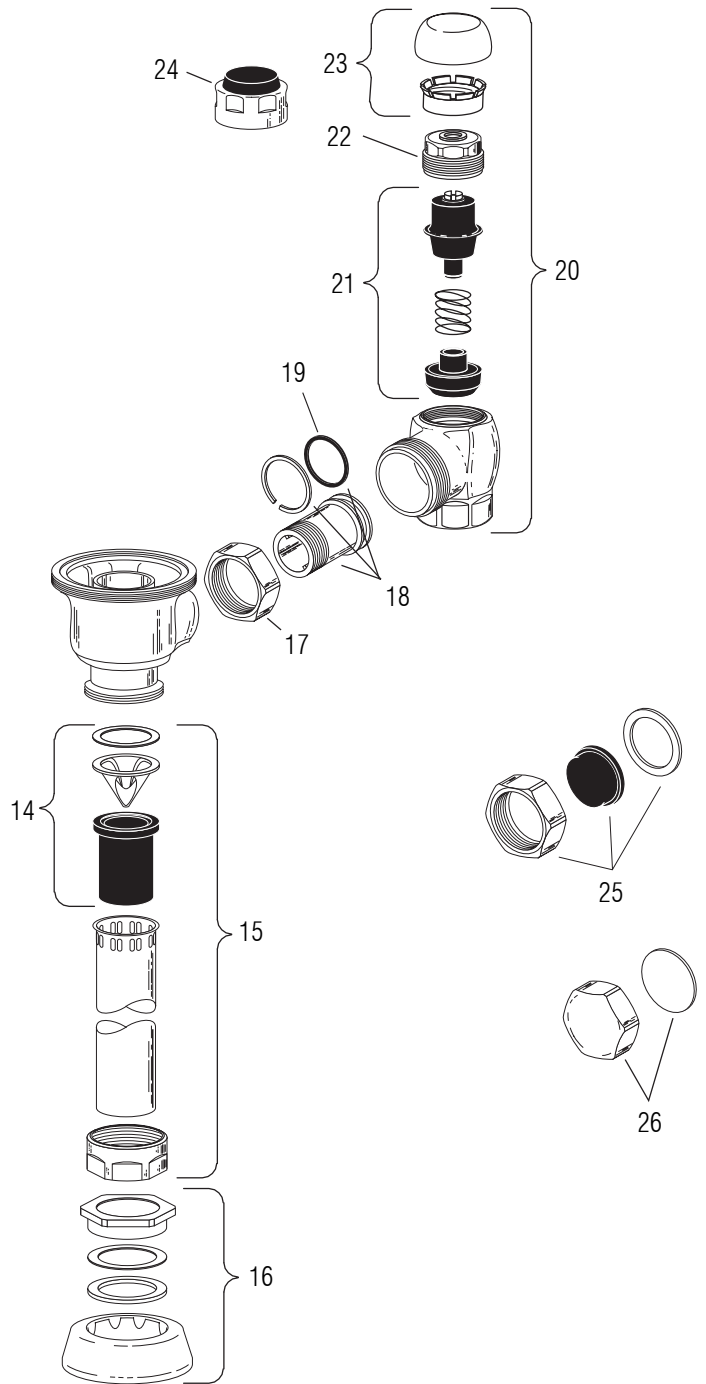
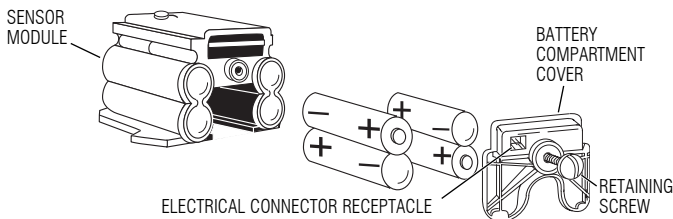

**Care and Cleaning Instructions**

**DO NOT** use abrasive or chemical cleaners to clean the G2 Optima Plus, they may dull the luster and attack the Plastic Cover and the chrome finish of the Flushometer. Use **ONLY** soap and water, then wipe dry with clean cloth or towel. While cleaning the bathroom tile, the Optima Plus should be protected from any splattering of cleaner. Acids and cleaning fluids can discolor or remove chrome plating.

## Troubleshooting and Maintaining the Sloan G2 Optima Plus® Flushometer

### I. Sensor Flashes Continuously Only When User Steps Within Range.

- A. Unit in Start-Up mode; no problem. This feature is active for the first ten (10) minutes of operation.

### II. Valve Does Not Flush; Sensor Not Picking Up User.

- A. Range too short; increase the range.

### III. Valve Does Not Flush; Sensor Picking Up Opposite Wall or Surface, or Only Flushes When Someone Walks By. Red Light Flashes Continuously for First 10 Minutes Even with No One in Front of the Sensor.

- A. Range too long; shorten range.

### IV. Valve Does Not Flush Even After Adjustment.

- A. Range Adjustment Potentiometer set at full "max" or full "min" setting. Readjust Potentiometer away from full "max" or "min" setting.
- B. Batteries completely used up; replace Batteries.
- C. Problem with Electronic Sensor Module; replace Electronic Sensor Module.

### V. Unit Flashes 4 Quick Times When User Steps Within Range.

- A. Batteries low; replace Batteries.

### VI. Valve Does Not Shut Off.

- A. Bypass Orifice in Diaphragm is clogged with dirt or debris, or Bypass is clogged by an invisible gelatinous film due to "over-treated" water. Remove Flex Tube Diaphragm and wash under running water.

**Note:** Size of Orifice in the Bypass is of utmost importance for the proper metering of water by the valve. **DO NOT ENLARGE OR DAMAGE THIS ORIFICE.** Replace Flex Tube Diaphragm if cleaning does not correct the problem.

- B. Dirt or debris fouling Stem or Flex Tube Diaphragm. Remove Flex Tube Diaphragm and wash under running water.
- C. O-ring on Stem of Flex Tube Diaphragm is damaged or worn. Replace O-ring if necessary.
- D. Problem with Solenoid. If cleaning does not correct problem, replace with new Isolated Solenoid Operator.

### VII. Not Enough Water to Fixture.

- A. Wrong Flush Volume Regulator installed in Flex Tube Diaphragm Kit. Install the correct Regulator (see Step 6 of Installation Instructions 0816452).
- B. Wrong Optima Plus model installed; i.e., 1 gpf. urinal installed on 3.5 gal. closet fixture. Replace with proper Optima Plus model, or refer to the G2 Optima Plus Conversion Guide (0816453) to convert existing unit to the proper model.
- C. Enlarged Bypass in Diaphragm. Replace Flex Tube Diaphragm.
- D. Control Stop not adjusted properly. Readjust Control Stop.
- E. Inadequate volume or pressure at supply. Increase water pressure or supply (flow) to Valve. Consult factory for assistance.

### VIII. Too Much Water to Fixture.

- A. Wrong Flush Volume Regulator installed in Flex Tube Diaphragm Kit. Install the correct Regulator (see Step 6 of Installation Instructions 0816452).
- B. Control Stop not adjusted properly. Readjust Control Stop.

- C. Wrong Optima Plus model installed; i.e., 3 gpf model installed on 1.0 or 1.5 gpf urinal fixture. Replace with proper Optima Plus model, or refer to the G2 Optima Plus Conversion Guide (0816453) to convert existing unit to the proper model.

- D. Dirt in Diaphragm Bypass. Clean under running water or replace Flex Tube Diaphragm.

**Note: The EBV-46-A Beam Deflector is no longer required or available for the G2 Optima Plus.**

**For information and instructions on field converting G2 Optima Plus Module settings or to activate the Stadium Flush™ Feature in urinal models, refer to the Sloan G2 Optima Plus Conversion Guide (0816453).**

**This manual and the Optima Plus Repair and Maintenance Guide are available at [www.sloanvalve.com](http://www.sloanvalve.com).**

### RANGE ADJUSTMENT (Adjust only If Necessary)

The G2 Optima Plus has a factory set sensing range:  
Water Closet Models — 22" to 42" (559 mm to 1067 mm)  
Urinal Models — 15" to 30" (381 mm to 762 mm)

**The Factory setting should be satisfactory for most installations.**

If the range is too short (i.e., not picking up users) or too long (i.e., picking up opposite wall or stall door) the range can be adjusted.

**Note:** Water does not have to be turned off to adjust range.

Loosen the two Screws on top of the unit. Remove the Override Button. Remove the Rubber Plug from top of Electronic Sensor Module to uncover the Potentiometer.

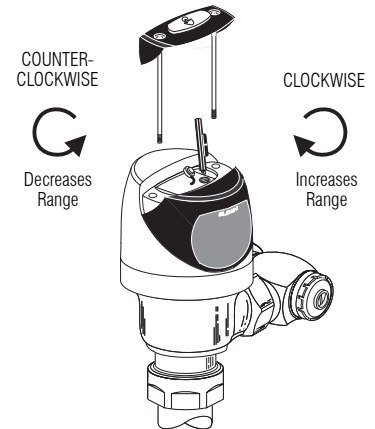

### RANGE ADJUSTMENT PROCEDURE

For the first ten (10) minutes of operation, a Visible Red Light flashes in the Sensing Window of the G2 Optima Plus Flushometer when a user is detected. This Visible Red Light feature can be reactivated after ten (10) minutes by opening and closing the Battery Compartment Door.

Check the range by stepping toward the unit until the Red Light flashes, indicating the Sensor's maximum detection limit. Adjust the Range Potentiometer Screw located on top of the Sensor Module a few degrees CLOCKWISE to increase the range or a few degrees COUNTERCLOCKWISE to decrease the range. Repeat this adjustment until the desired range is achieved.

**Always Determine the Sensing Range with Metal Cover and Lens Window On Top of the Unit.**

**Important:** Adjust in small increments only! Range Potentiometer adjustment screw rotates only 3/4 of a turn; DO NOT over-rotate.

When range adjustment is satisfactory, replace the Rubber Plug. Reinstall Override Button and tighten the two Screws on top of the unit.

**AIR DELIGHTS, INC. • 9974 SW ARCTIC DR. • BEAVERTON, OR. 97005**

Phone: 1-800-440-5556 or 1-503-352-1201 • Fax: 1-503-643-8224 • [www.airdelights.com](http://www.airdelights.com)