

# SLOAN<sup>®</sup>

## FLUSHOMETERS

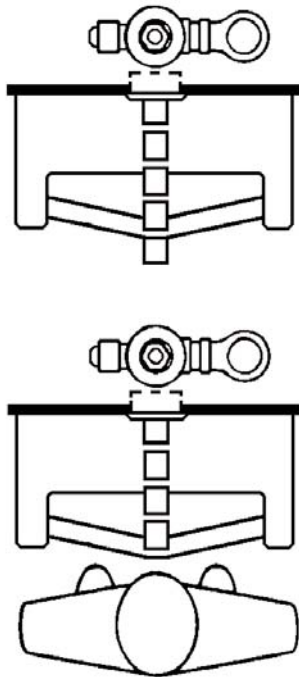
Maintenance Guide

• SENSOR OPERATED VALVES



## OPTIMA<sup>®</sup> Flushometers

The Sloan OPTIMA automatic electronic Flushometer relies on an infrared sensor to detect a user and activate a flushing cycle. No physical contact with the Flushometer surface is necessary, assuring sanitary protection. OPTIMA Flushometers are ADA-compliant devices and are available in both Royal<sup>®</sup> and Regal<sup>®</sup> Flushometer models. These hardwire Flushometers require the use of 24 VAC Stepdown Transformers.



The Flushometer is triggered by means of a self-adaptive infrared sensor. A flashing red indicator light identifies the presence of a target. After a detected user moves out of the effective range of the sensor, a signal is sent to the Flushometer Solenoid and, after appropriate arming and/or flush delays, the flush cycle is initiated. When a unit is used intermittently, the Sentinel Flush feature ensures a cleansing cycle at least once in any 24-hour period.

**NOTE:** Sensor location and positioning is critical. Failure to properly position the electrical box to the recommended plumbing rough-in dimensions will result in improper installation and may impair product performance. All tradesmen (plumbers, electricians, tile setters, etc.) involved in the installation of this product must coordinate their work efforts to ensure proper product installation. Improper installation may nullify the manufacturer's warranty.

## OPTIMA Components:

### EL-1500 Series Sensor

- Self-adaptive Sensor
- Flashing Red Light Indicator
- Replaceable Sensor Window
- Two-wire connection system

### Solenoid

- Non-Hold-Open Integral Solenoid Operator

### Transformer

#### 24 VAC Stepdown Transformer

- EL-154 for 120 VAC Electrical Supply (50/60 Hz)
- EL-342 for 220/240 VAC Electrical Supply (50/60 Hz)

### Override Button

- Courtesy Flush  
(available only on Water Closet installations)

### Cover Plates

- Override Button Sensor Cover Plate  
(Exposed and Concealed Water Closet installations)
- Solenoid Cover Plate  
(Exposed Water Closet and Urinal installations)
- Urinal Sensor Cover Plate  
(Concealed Urinal installations)

### Wall Box Option

- Stainless Steel or Polished Brass Surface Finish
- Concealed installation
- Vandal Resistant

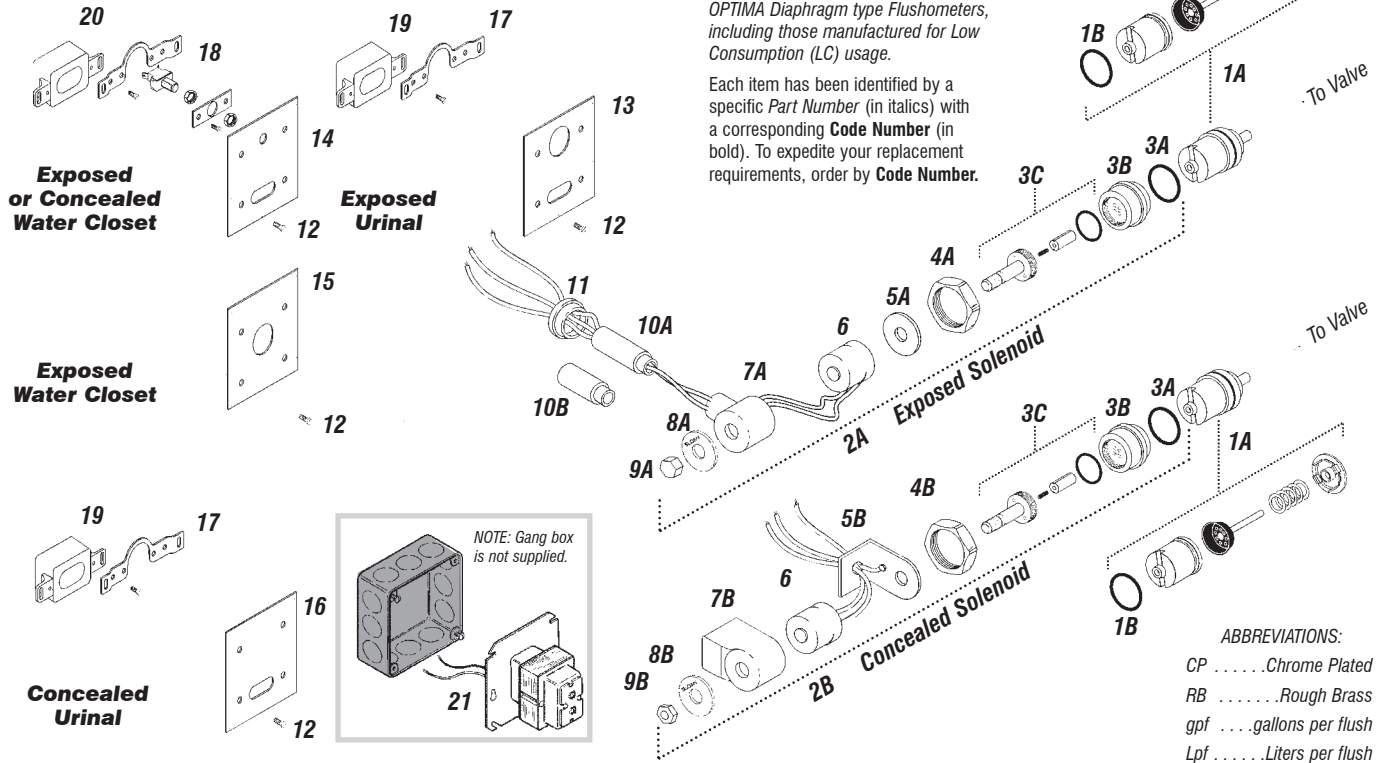
## LIMITED WARRANTY

Sloan Valve Company warrants its Flushometer Products to be made of first class materials, free from defects of material or workmanship under normal use and to perform the service for which they are intended in a thoroughly reliable and efficient manner when properly installed and serviced, for a period of three years (one year for special finishes) from date of purchase. During this period, Sloan Valve Company will, at its option, repair or replace any part or parts which prove to be thus defective if returned to Sloan Valve Company, at customer's cost, and this shall be the sole remedy available under this warranty. No claims will be allowed for labor, transportation or other incidental costs. This warranty extends only to persons or organizations who purchase Sloan Valve Company's products directly from Sloan Valve Company for purpose of resale.

**THERE ARE NO WARRANTIES WHICH EXTEND BEYOND THE DESCRIPTION ON THE FACE HEREOF. IN NO EVENT IS SLOAN VALVE COMPANY RESPONSIBLE FOR ANY CONSEQUENTIAL DAMAGES OF ANY MEASURE WHATSOEVER.**

The Repair Kits and Parts listed on these pages are designed to service all Sloan OPTIMA Diaphragm type Flushometers, including those manufactured for Low Consumption (LC) usage.

Each item has been identified by a specific Part Number (in italics) with a corresponding Code Number (in bold). To expedite your replacement requirements, order by Code Number.



### Solenoid/Sensor Parts and Assemblies List

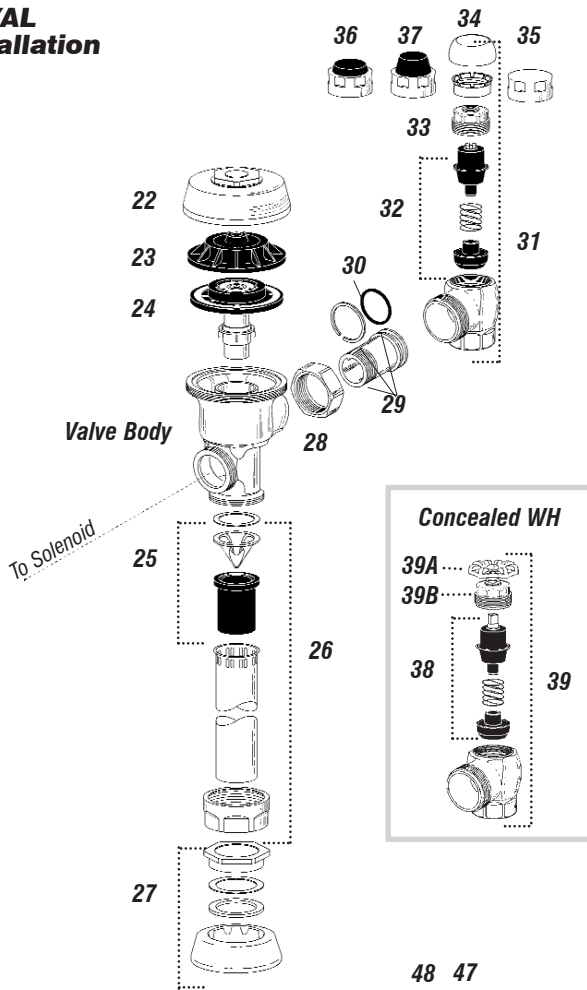
Code Number	Part Number	Description
1A	<b>3305043</b> EL-128-A	Actuator Cartridge Assembly Repair Kit <i>Includes Spring, EL-110 O-Ring, Plunger Guide, Solenoid Valve Seat, Valve Piston Assembly, and DO-22 O-Ring.</i>
1B	<b>0305135</b> EL-110	O-Ring
2A	<b>0305329</b> EL-124-2	CP 24 VAC Solenoid Assembly (exposed installation) <i>Includes A-6 CP Handle Coupling (0301082), EL-165-2 24 VAC Coil (0305118), EL-101 CP Nut for Solenoid (0305125), EL-102-2 Face Plate for 24 VAC Solenoid (0305127), EL-104 CP Adapter for Solenoid (0305132), EL-162 CP Solenoid Housing (0305164), EL-163-A Solenoid Shaft Assembly (0305165), EL-164 Solenoid Flux Plate (0305166), and DO-22 O-Ring (0337086).</i>
2B	<b>0305331</b> EL-138-2	RB 24 VAC Solenoid Assembly (concealed installation) <i>Includes A-6 RB Handle Coupling (0301082PO), EL-165-2 24 VAC Coil (0305118), EL-102-2 Face Plate for 24 VAC Solenoid (0305127), EL-104 CP Solenoid Adapter (0305132), EL-163-A Solenoid Shaft Assembly (0305165), EL-166 Housing Nut for Solenoid (0305167), EL-137 Solenoid Flux Plate (0305332), and EL-136 Solenoid Housing (0305336).</i>
3A	<b>0337086</b> DO-22	O-Ring
3B	<b>0305132</b> EL-104	CP Adapter for Solenoid
3C	<b>0305165</b> EL-163-A	Solenoid Shaft Assembly <i>Includes Gasket, Plunger, Plunger Spring, and Solenoid Shaft.</i>
4A	<b>0301082</b> A-6	CP Handle Coupling (exposed installation)
4B	<b>0301083</b> A-6	RB Handle Coupling (concealed installation)
5A	<b>0305166</b> EL-164	Solenoid Flux Plate (exposed installation)
5B	<b>0305332</b> EL-137	Solenoid Flux Plate (concealed installation)
6	<b>0305118</b> EL-165-2	24 VAC Coil
7A	<b>0305164</b> EL-162	CP Solenoid Housing (exposed installation)
7B	<b>0305336</b> EL-136	CP Solenoid Housing (concealed installation)
8A	<b>0305127</b> EL-102-2	Face Plate for 24 VAC Solenoid (exposed installation)
8B	<b>0305333</b> EL-102-4	Face Plate for 24 VAC Solenoid (concealed installation)
9A	<b>0305125</b> EL-101	CP Nut for Solenoid (exposed installation)
9B	<b>0305167</b> EL-166	Housing Nut for Solenoid (concealed installation)
10A	<b>0305145</b> EL-123-A	CP Nipple Assembly (exposed installation)
10B	<b>0305337</b> EL-226	CP Extension Nipple Adapter

NOTE: When the distance between Center Line of valve to finished wall is greater than 3" (76 mm) use the EL-226 Extension Nipple Adapter. These Adapters can be coupled as needed.

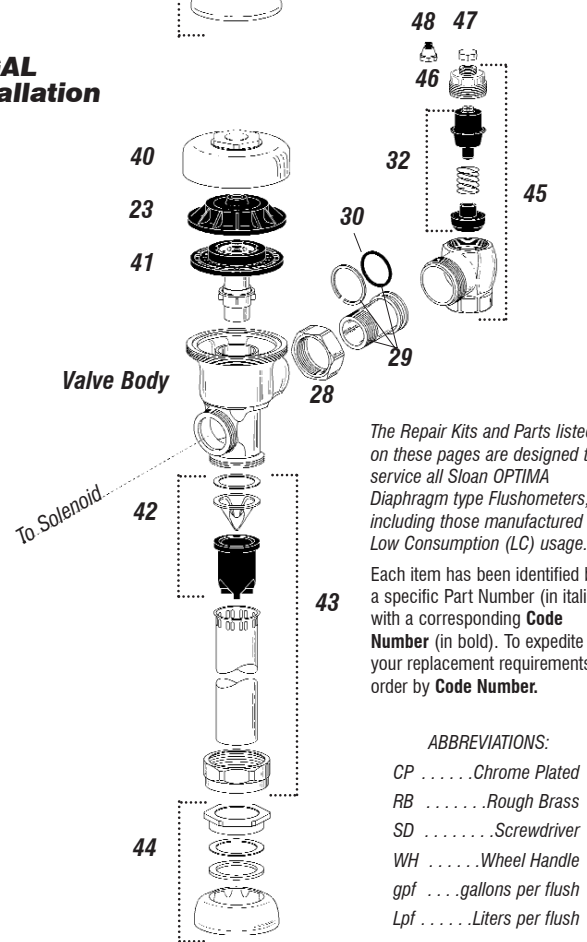
### Solenoid/Sensor Kits List

Code Number	Part Number	Description
—	<b>3305045</b> EL-124-2A	CP 24 VAC Solenoid Assembly for exposed applications <i>Includes EL-124-2 CP 24 VAC solenoid assembly (0305131) and EL-128-A actuator cartridge assembly repair kit (3305043).</i>
—	<b>3305154</b> EL-1001-A	Closest Flushometer Electronic Accessories Kit with Override <i>Includes four EL-152 screws (0305152), EL-170 5/64" hex wrench (0305170), EL-201 CP plate for 2-gang electrical box (0305219), EL-202 mounting plate (0305220), two EL-204 screws (0305221), EL-203 override switch (0305234), EL-168-A yoke assembly (0305323), EL-1500-L closet sensor replacement kit (0305923), an OPTIMA sticker and sensor Installation Instructions.</i>
—	<b>3305170</b> EL-1005-A	Exposed Urinal Flushometer Electronic Accessories Kit <i>Includes EL-151 CP plate for 2-gang electrical box (0305151), four EL-152 screws (0305152), EL-153 yoke (0305153), EL-170 5/64" hex wrench (0305170), two EL-177 screws (0305177), EL-178 washer (0305178), EL-1500 urinal sensor replacement kit (0305922), an OPTIMA sticker and sensor Installation Instructions.</i>
—	<b>3305172</b> EL-1007-A	Concealed Urinal Flushometer Electronic Accessories Kit <i>Includes four EL-152 screws (0305152), EL-153 yoke (0305153), EL-161 CP plate for 2-gang electrical box (0305161), EL-170 5/64" hex wrench (0305170), two EL-177 screws (0305177), EL-178 washer (0305178), EL-1500 urinal sensor replacement kit (0305922), an OPTIMA sticker and sensor Installation Instructions.</i>

## ROYAL Installation



## REGAL Installation



The Repair Kits and Parts listed on these pages are designed to service all Sloan OPTIMA Diaphragm type Flushometers, including those manufactured for Low Consumption (LC) usage.

Each item has been identified by a specific Part Number (in italics) with a corresponding **Code Number** (in bold). To expedite your replacement requirements, order by **Code Number**.

- ABBREVIATIONS:**
- CP . . . . .Chrome Plated
  - RB . . . . .Rough Brass
  - SD . . . . .Screwdriver
  - WH . . . . .Wheel Handle
  - gpf . . . . .gallons per flush
  - Lpf . . . . .Liters per flush

## Valve Parts List

**NOTE:** Also refer to the Royal, Regal, Control Stop and Flush Connection Maintenance Guides.

### Royal

Code No.	Part No.	Part/Assembly
22	<b>0301172</b>	A-72 CP Cover
23	<b>0301168</b>	A-71 Inside Cover
24	<b>SEE DIAPHRAGM ASSEMBLY CHART ON PAGE 4</b>	
25	<b>3323182</b>	V-651-A Vacuum Breaker Repair Kit
26	<b>0393004</b>	V-600-AA 3/4" (19 mm) x 9" (229 mm) CP Vacuum Breaker
	<b>0393006</b>	V-600-AA 1-1/4" (32 mm) x 9" (229 mm) CP Vacuum Breaker
	<b>0393007</b>	V-600-AA 1-1/2" (38 mm) x 9" (229 mm) CP Vacuum Breaker
27	<b>0306125</b>	F-5-AW 3/4" (19 mm) CP Spud Coupling Assembly
	<b>0306140</b>	F-5-AU 1-1/4" (32 mm) CP Spud Coupling Assembly
	<b>0306146</b>	F-5-AT 1-1/2" (38 mm) CP Spud Coupling Assembly
28	<b>0308676</b>	H-550 CP Stop Coupling
29	<b>0308801</b>	H-551-A CP Adjustable Tail 2-1/16" (52 mm) long
30	<b>5308696</b>	H-553 "O" Ring - 24 per pkg.
31	<b>3308386</b>	H-700-A 1" (25 mm) Screwdriver Bak-Chek® Angle Stop CP - complete
	<b>3308384</b>	H-700-A 3/4" (19 mm) Screwdriver Bak-Chek® Angle Stop CP - complete
32	<b>3308853</b>	H-541-A-SD Control Stop Repair Kit <i>for use with 1" (25 mm) &amp; 3/4" (19 mm) H-700-A, 1" (25 mm) H-600-A, 1" (25 mm) &amp; 3/4" (19 mm) H-740-A and 1" (25 mm) H-540-A SD Stops</i>
	<b>3308856</b>	H-543-A-SD Control Stop Repair Kit <i>for use with 3/4" (19 mm) H-600-A and H-540-A SD Stops</i>
33	<b>0308612</b>	H-622 CP Bonnet <i>for use with 1" (25 mm) &amp; 3/4" (19 mm) H-700-A and 1" (25 mm) H-600-A SD Stops</i>
	<b>0308843</b>	H-577 CP Bonnet <i>for use with 3/4" (19 mm) H-600-A SD Stops</i>
34	<b>3308791</b>	H-1010-A 1" (25 mm) Vandal Resistant Control Stop Cap Assembly <i>for use with 1" (25 mm) &amp; 3/4" (19 mm) H-700-A and 1" (25 mm) H-600-A SD Stops</i>
	<b>3308790</b>	H-1009-A 3/4" (19 mm) Vandal Resistant Control Stop Cap Assembly <i>for use with 3/4" (19 mm) H-600-A SD Stops</i>
35	<b>0308840</b>	H-573 1" (25 mm) Control Stop Cap CP <i>for use with 1" (25 mm) &amp; 3/4" (19 mm) H-700-A and 1" (25 mm) H-600-A SD Stops</i>
	<b>0308848</b>	H-582 3/4" (19 mm) Control Stop Cap CP <i>for use with 3/4" (19 mm) H-600-A SD Stops</i>
36	<b>3308866</b>	H-574 1" (25 mm) Control Stop Cap with Bumper <i>for use with 1" (25 mm) &amp; 3/4" (19 mm) H-700-A and 1" (25 mm) H-600-A SD Stops</i>
37	<b>3308867</b>	H-576 1" (25 mm) Control Stop Cap with Extended Bumper <i>for use with 1" (25 mm) &amp; 3/4" (19 mm) H-700-A and 1" (25 mm) H-600-A SD Stops</i>
38	<b>3308860</b>	H-1006-A Repair Kit for 1" (25 mm) Stops with Concealed WH <i>for use with 1" (25 mm) H-700, H-600, and H-540 WH Series Stops</i>
	<b>3308859</b>	H-1007-A Repair Kit 3/4" (19 mm) Stops with Concealed WH <i>for use with 3/4" (19 mm) H-700 WH Series Stops</i>
39	<b>0388010</b>	H-730-A 1" (25 mm) Concealed WH Bak-Chek® Angle Stop RB
	<b>0388011</b>	H-730-A 3/4" (19 mm) Concealed WH Bak-Chek® Angle Stop RB
39A	<b>3308872</b>	H-1011-A Repair Kit (for Concealed WH only; does not include bonnet)
39B	<b>0208083</b>	H-623 Bonnet
	<b>0308705</b>	H-561 Bonnet

### Regal

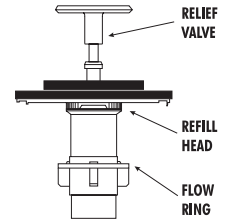
Code No.	Part No.	Part/Assembly
23	<b>0301168</b>	A-71 Inside Cover
28	<b>0308676</b>	H-550 CP Stop Coupling
29	<b>0308801</b>	H-551-A CP Adjustable Tail 2-1/16" (52 mm) long
30	<b>5308696</b>	H-553 "O" Ring - 24 per pkg.
32	<b>3308853</b>	H-541-A-SD Control Stop Repair Kit <i>for use with 1" (25 mm) &amp; 3/4" (19 mm) H-700-A, 1" (25 mm) H-600-A, 1" (25 mm) &amp; 3/4" (19 mm) H-740-A and 1" (25 mm) H-540-A SD Stops</i>
	<b>3308856</b>	H-543-A-SD Control Stop Repair Kit <i>for use with 3/4" (19 mm) H-600-A and H-540-A SD Stops</i>
40	<b>0317004</b>	R-10 CP Cover
41	<b>SEE INSIDE PARTS ASSEMBLY CHART ON PAGE 4</b>	
42	<b>3323192</b>	V-551-A Vacuum Breaker Repair Kit
43	<b>0323005</b>	V-500-AA 3/4" (19 mm) x 9" (229 mm) CP Vacuum Breaker
	<b>0323006</b>	V-500-AA 1-1/4" (32 mm) x 9" (229 mm) CP Vacuum Breaker
	<b>0323007</b>	V-500-AA 1-1/2" (38 mm) x 9" (229 mm) CP Vacuum Breaker
44	<b>0306102</b>	F-54-A 3/4" (19 mm) CP Spud Coupling Assembly
	<b>0306142</b>	F-55-A 1-1/4" (32 mm) CP Spud Coupling Assembly
	<b>0306145</b>	F-56-A 1-1/2" (38 mm) CP Spud Coupling Assembly
45	<b>0388029</b>	H-740-A 1" (25 mm) SD Bak-Chek® Stop CP - complete
	<b>0388031</b>	H-740-A 3/4" (19 mm) SD Bak-Chek® Stop CP - complete
46	<b>0308991</b>	H-639 CP Bonnet <i>for use with H-740-A 1" (25 mm) &amp; 3/4" (19 mm) and H-540-A 1" (25 mm) SD Stops</i>
	<b>0308601</b>	H-538 CP Bonnet <i>for use with H-540-A 3/4" (19 mm) SD Stops</i>
47	<b>5308156</b>	H-37 CP Cap (package of 6)
48	<b>5310034</b>	J-2/J-7 Bumper Assembly (package of 6)

# Royal ESS item 24 - Dual Filtered Diaphragm™ Assembly ••• Sold ONLY in ROYAL Performance™ Kits

**ESS KIT** includes: EL-128-A Actuator Cartridge Assembly (item 1A); Dual Filtered Diaphragm Assembly (item 24); High Back Pressure Vacuum Breaker Repair Kit (item 25); and one Tailpiece "O" Ring (item 30). **DIAPHRAGM ONLY KIT** includes: Dual Filtered Diaphragm Assembly (item 24) ONLY

ESS KIT		DIAPHRAGM ONLY KIT		Flush Volume	Use With	Relief Valve	Refill Head*	Flow Ring
Code No.	Kit No.	Code No.	Kit No.					
A	3345013 EL-1101-A	3301502	A-1041-A	1.6 gpf/6.0 Lpf	Low Consumption Water Closets	Green	Gray	Smooth
B	3345014 EL-1102-A	3301501	A-1038-A	3.5 gpf/13.2 Lpf	Water Saver Water Closets	White	Gray	Smooth
C	3345015 EL-1103-A	3301505	A-1044-A	2.4 gpf/9.0 Lpf	9 Liter European Water Closets	Blue	Gray	Smooth
D	3345016 EL-1106-A	3301504	A-1043-A	0.5 gpf/1.9 Lpf	Wash Down Urinals	Green	Black	Smooth & Slotted
E	3345017 EL-1107-A	3301503	A-1042-A	1.0 gpf/3.8 Lpf	Low Consumption Urinals	Green	Black	Slotted
F	3345018 EL-1108-A	3301500	A-1037-A	1.5 gpf/5.7 Lpf	Water Saver Urinals	Black	Black	Smooth

To identify the Flush Volume of a DUAL FILTERED DIAPHRAGM ASSEMBLY, look at the color of the Relief Valve, the Refill Head and the shape of Flow Ring.

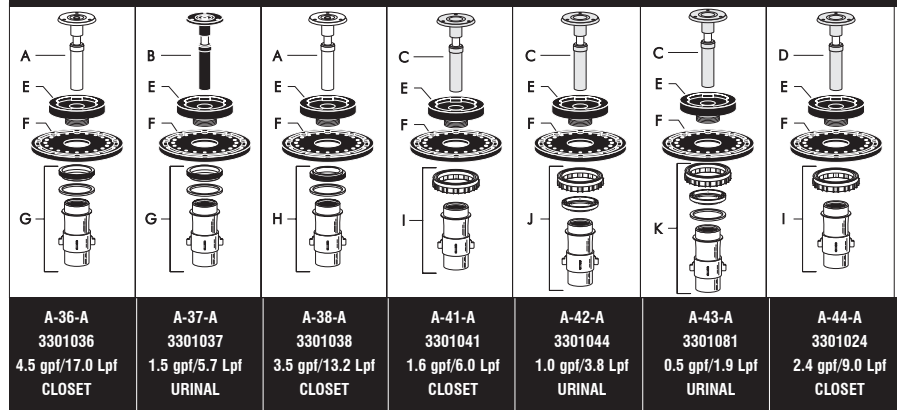


\*NOTE: Water Closet Refill Heads (Gray) have larger slots than Urinal Refill Heads (Black).

## Regal Inside Parts List\*\*

A	5301058	A-19-AC	Relief Valve, White (Closet)
B	5301059	A-19-AU	Relief Valve, Black (Urinal)
C	5301211	A-19-ALC	Relief Valve, Green (Closet/Urinal-Low Consumption)
D	5301143	A-19-AL	Relief Valve, Blue (9 Liter Closet)
E	5301111	A-15-A	Disc
F	5301188	A-156-A	Diaphragm
G	5301236	A-163-A	Guide Assembly 4.5 gpf/17.0 Lpf Closet and 1.5 gpf/5.7 Lpf Urinal
H	5301032	A-152-A	Guide Assembly 3.5 gpf/13.2 Lpf Closet
I	5301031	A-151-A	Guide Assembly 1.6 gpf/6.0 Lpf Closet
J	5301155	A-155-A	Guide Assembly 1.0 gpf/3.8 Lpf Urinal
K	5301157	A-157-A	Guide Assembly 0.5 gpf/1.9 Lpf Urinal

## Regal ESS item 41- Inside Parts Kits Assembly



\*\*NOTE: All Regal inside part items are supplied in packages of 12.

## Wall Box Kits

### Closet Models

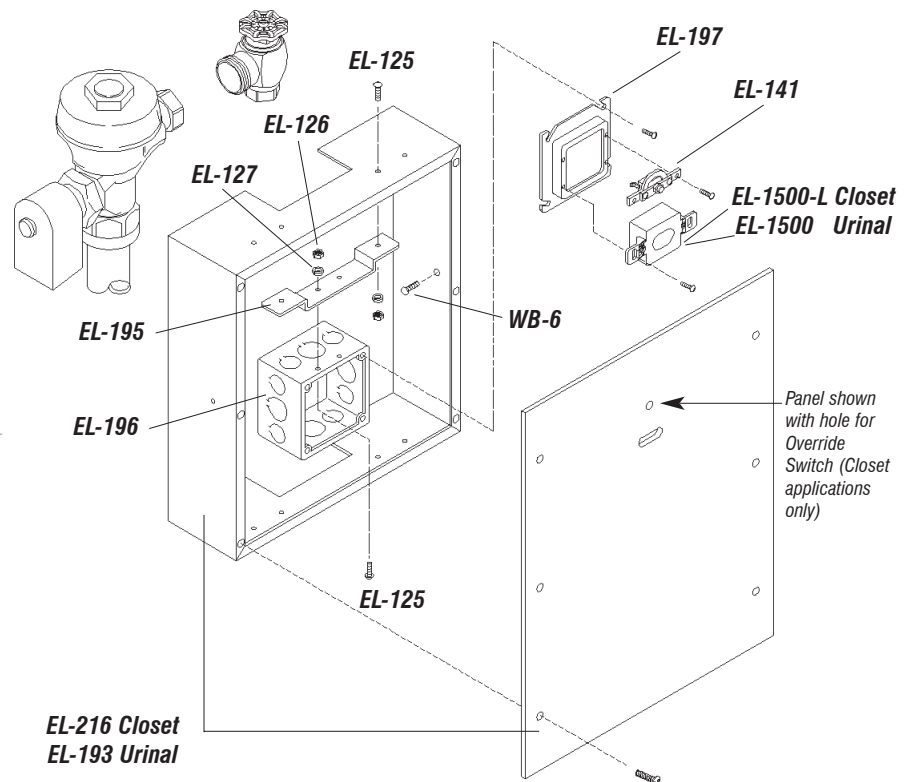
- 3305180 EL-192-A Closet Wall Box Kit - Stainless Steel  
Includes four EL-125 Mounting Screws, four EL-126 Hex Nuts, four EL-127 Lock Washers, EL-195 Mounting Bracket, EL-196 Electrical Box, EL-197 Electrical Box Cover, EL-141-A Override Switch Subassembly, EL-216 Wall Box 13" x 17" (330 mm x 432 mm) with 14.5" x 18.5" (368 mm x 470 mm) Stainless Steel Wall Box Cover with hole for override switch, EL-318 Spanner Bit, EL-1500-L Closet Sensor Replacement Kit, and four WB-6 Screws.

- 3305179 EL-192-A Closet Wall Box Kit - Polished Brass  
Includes the same components as 3305180 listed above except unit is furnished with Polished Brass 14.5" x 18.5" (368 mm x 470 mm) Wall Box Cover (instead of Stainless Steel).

### Urinal Models

- 3305178 EL-191-A Urinal Wall Box Kit - Stainless Steel  
Includes four EL-125 Mounting Screws, four EL-126 Hex Nuts, four EL-127 Lock Washers, EL-193 Wall Box 13" x 17" (330 mm x 432 mm) with 14.5" x 18.5" (368 mm x 470 mm) Stainless Steel Wall Box Cover, EL-195 Mounting Bracket, EL-196 Electrical Box, EL-197 Electrical Box Cover, EL-318 Spanner Bit, EL-1500 Urinal Sensor Replacement Kit, and four WB-6 Screws.

- 3305177 EL-191-A Urinal Wall Box Kit - Polished Brass  
Includes the same components as 3305178 listed above except unit is furnished with Polished Brass 14.5" x 18.5" (368 mm x 470 mm) Wall Box Cover (instead of Stainless Steel).



## Sensor Replacement

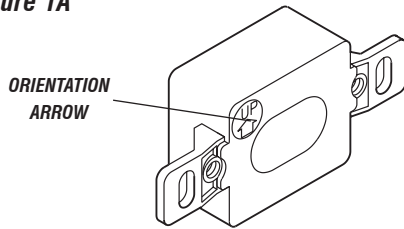
**NOTE:** The EL-1500 Series OPTIMA Sensor (a two-wire unit) replaces the older EL-150 Series Sensors (either three-wire or four-wire units). Refer to the Wiring History shown below.

### IMPORTANT

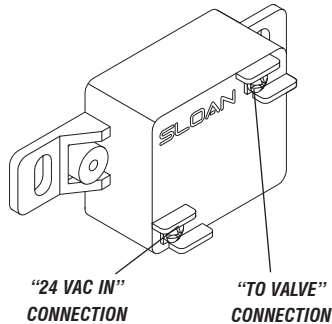
- Be certain to disconnect the 24 VAC power supply either at the transformer or the fuse box. Failure to disable the power supply can result in damage to the EL-1500 Series Sensor.
- The Solenoid Operator must be removed from the Valve on exposed urinal installations. Do not damage the O-ring seal on the operator assembly.

- 1 Remove the Cover Plate (for Wall Box Installation, remove Cover Panel) and old Sensor from the wall installation. Use a 5/64" hex wrench to remove the Cover Plate Screws (or #8 drilled spanner head screwdriver EL-318 to remove the vandal-resistant screws from the Wall Box Cover Panel.)

**Figure 1A**

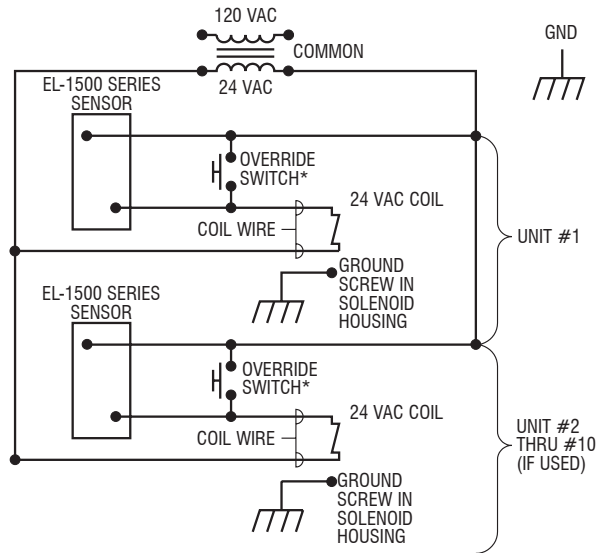


**Figure 1B**



- 2 Connect one 24 VAC lead to the Sensor Terminal labeled "24 VAC IN" (see Figure 1B).
  - On an old three-wire EL-150 series Sensor, this wire was connected to the BLACK Sensor lead.
  - On an old four-wire EL-150 series Sensor, this wire was connected to the BROWN Sensor lead.
- 3 Connect one Solenoid Lead to the Sensor Terminal labeled "TO VALVE" (see Figure 1B).
  - On an old three-wire or four-wire EL-150 Series Sensor, this wire was connected to the RED Sensor Lead.
- 4 Connect the remaining 24 VAC lead to the remaining Solenoid Lead.
  - On an old three-wire EL-150 Series Sensor, these wires were connected to the WHITE Sensor Leads.
  - On an old four-wire EL-150 Series Sensor, these wires were connected to the YELLOW and BLUE (or in very early models, the inner BROWN) Sensor Leads.
- 5 On Water Closet installations only, connect the Override Button (shown as the Override Switch in Wiring Diagram) parallel to the EL-1500-L Sensor.
- 6 Reinstall the Sensor with the Orientation Arrow on the Lens side of the Sensor pointing UP (see Figure 1A). Replace the Cover Plate (or Wall Box Panel) and tighten the Cover Plate (or Wall Box Panel) Screws.
- 7 Reconnect the 24 VAC power supply at the transformer or the fuse box.

## WIRING DIAGRAM



**Figure 2**

\* OVERRIDE SWITCH USED WITH WATER CLOSETS ONLY

**NOTE:** A MAXIMUM OF TEN (10) SENSOR FLUSHOMETER UNITS CAN OPERATE FROM ONE (1) SLOAN EL-154 TRANSFORMER. CLASS 2 UL LISTED, 48 VA (MIN.) AT 24 VAC, PLATE MOUNTED.

## Start-Up Mode

**NOTE:** It is important that only permanent targets are present at this time.

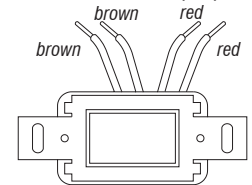
The self-adaptive sensor automatically adjusts to the surrounding environment when the 24 volt supply is activated. No manual adjustment is required. The start-up cycle completes in approximately five (5) minutes. A continuous red light visible in the Sensor Window indicates the Start-up Mode. If the red light flashes, the Sensor detects a target. Unless this target is a permanent fixture in the Sensor's environment (i.e., a wall or stall door), it must be removed from the view of the Sensor. If a target is permanent, the Sensor will adapt itself around this target. In this case, the Start-Up Mode may take up to 10 (ten) minutes. When the Start-Up cycle is complete, the red light will no longer be visible in the Sensor Window.

**NOTE:** If the 24 volt power supply is ever interrupted for longer than fifteen (15) seconds, the start-up mode begins automatically when power is restored.

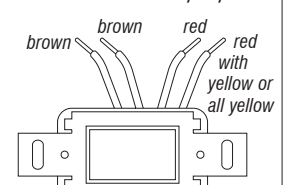
Incorrect wiring or a short in the 24 volt power supply will initiate a warning signal in the Sensor Window. The visible light flashes a continuous "S-O-S" signal: three (3) slow, three (3) fast, and three (3) slow flashes.

### EL-150 Wiring History for 4-wire and 3-wire sensors

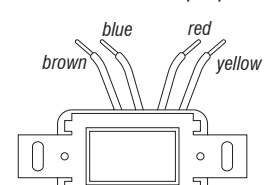
#### Release date 03/09/78



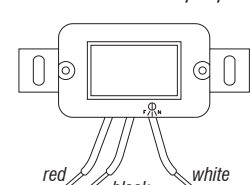
#### Release date 08/11/83



#### Release date 02/02/87



#### Release date 12/12/90



## Troubleshooting Guide

**NOTE:** Upon detection of the user, the red indicator light flashes **slowly** for a period of eight seconds. When the user leaves the detection range, the indicator light flashes **rapidly** and the Sensor initiates the flush sequence. Then the indicator light **stops** flashing and the valve flushes. (On water closet models, the valve will flush after a three-second delay).

**1. PROBLEM: Valve does not function (red light does not flash when user steps in front of sensor).**

**CAUSE:** No power is being supplied to sensor.

**SOLUTION:** Ensure that the main power is turned "ON". Check transformer, leads and connections. Repair or replace as necessary.

**CAUSE:** EL-1500/EL-1500-L Sensor is not operating.

**SOLUTION:** Replace EL-1500/EL-1500-L Sensor.

**2. PROBLEM: Valve does not function (red light flashes when user steps in front of Sensor).**

**INDICATOR:** The red light stops flashing when user steps away and the valve makes a "clicking" sound but does NOT flush.

**CAUSE:** No water is being supplied to the valve.

**SOLUTION:** Make certain that water supply is turned "ON" and the Control Stop is open.

**CAUSE:** EL-128-A cartridge is fouled or jammed.

**SOLUTION:** Turn electronic power to valve "OFF" (failure to do so could result in damage to the solenoid coil). Remove the solenoid operator from the valve and remove the EL-128-A cartridge. Clean and/or repair as necessary.

**INDICATOR:** The red light stops flashing when user steps away but the valve does NOT make a "clicking" sound and does NOT flush.

**CAUSE:** EL-163-A solenoid shaft assembly is fouled or jammed.

**SOLUTION:** Turn electronic power to valve "OFF" (failure to do so could result in damage to the solenoid coil). Remove EL-101 or EL-166 nut from the solenoid operator. Remove the coil from the solenoid operator. Use a spanner wrench or pliers to remove the EL-163-A solenoid shaft assembly from valve. Clean and/or replace as necessary. Be sure to replace plunger spring when reassembling Solenoid Shaft Assembly.

**INDICATOR:** The red light flashes three (3) short flashes, three (3) long flashes then three (3) short flashes ("S-O-S") and continues to repeat this cycle even when user steps out of the sensor's detection range.

**CAUSE:** EL-1500/EL-1500-L Sensor wiring connections are incorrect.

**SOLUTION:** Rewire Sensor to valve. One solenoid lead connects to the "TO VALVE" connection on Sensor. One transformer lead connects to the "24 VAC IN" connection on Sensor. Second solenoid lead and second transformer lead connect together.

**CAUSE:** Wiring to Sensor is ground shorted.

**SOLUTION:** Find short in wiring circuit and correct.

**CAUSE:** EL-162-2 solenoid coil is burnt out or coil is not connected to solenoid plunger shaft.

**SOLUTION:** Reinstall or replace coil as necessary.

**3. PROBLEM: Volume of water is insufficient to adequately siphon fixture.**

**CAUSE:** Control Stop is not open wide enough.

**SOLUTION:** Adjust control stop for desired water delivery.

**CAUSE:** Low Consumption unit is installed on Water Saver or Conventional fixture.

**SOLUTION:** Replace Diaphragm component parts of valve with kit that corresponds to appropriate flush volume of fixture.

**CAUSE:** Inadequate water volume or pressure available from supply.

**SOLUTION:** Increase pressure or supply (flow rate) to the valve. Consult factory for assistance.

**4. PROBLEM: Length of flush is too long (long flushing) or valve fails to shut off.**

**CAUSE:** Water Saver valve is installed on Low Consumption fixture.

**SOLUTION:** Replace Diaphragm component parts of valve with kit that corresponds to appropriate flush volume of fixture.

**CAUSE:** Relief valve in diaphragm is not seated properly or bypass hole in diaphragm is clogged.

**SOLUTION:** Disassemble inside Diaphragm component parts and wash parts thoroughly. Replace worn parts if necessary.

**5. PROBLEM: Water splashes from fixture.**

**CAUSE:** Supply flow rate is more than necessary.

**SOLUTION:** Adjust Control Stop to meet flow rate required for proper cleansing of the fixture.

**CAUSE:** Closet valve is installed on urinal fixture.

**SOLUTION:** Replace closet Diaphragm component parts with proper urinal kit (Inside Diaphragm Assembly or Inside Parts Kit)

### Care and Cleaning Instructions

DO NOT USE abrasive or chemical cleaners to clean Flushometers that may dull the luster and attack the chrome or special decorative finishes. Use ONLY soap and water, then wipe dry with a clean towel or cloth.

When cleaning the bathroom tile, protect the Flushometer from any splattering of cleaner. Acids and cleaning fluids can discolor or remove chrome plating.

.....  
If further assistance is required, please call

**1-800-440-5556**

The information contained in this document is subject to change without notice.

AIR DELIGHTS, INC. - 9974 SW ARCTIC DR. - BEAVERTON, OREGON 97005

Phone: 1-800-440-5556 or 1-503-352-1201 • Fax: 1-503-643-8224 • <http://www.airdelights.com>