

VISUAL INSTALLATION GUIDELINES FOR SLOAN



FLUSHOMETERS



RESS UNIT INSTALLATION

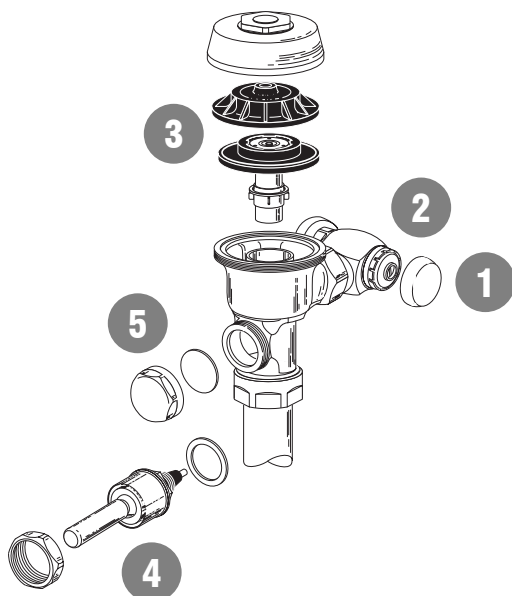

- 1 Remove Control Stop Cap.
- 2 Turn off water supply at Control Stop. Push valve Handle to relieve pressure.
- 3 Remove Outside and Inside Covers and old Inside Parts Assembly.
- 4 Remove old Handle Assembly and Gasket.
- 5 Install new Handle Seal and Handle Cap to Flushometer Valve Body.

G2 Optima Plus Flush Volume For RESS-C and RESS-U Retrofit Models

The Flush Volume of the Optima Plus is controlled by the Regulator in the Flex Tube Diaphragm Kit. Regulators are identified by color.

Reference Chart

Fixture & Flush	Regulator Color
0.5 gpf (1.9 Lpf) Urinal	Green
1.0 gpf (3.8 Lpf) Urinal	Green
1.5 gpf (5.7 Lpf) Urinal	Black
1.6 gpf (6.0 Lpf) Closet	Green
3.5 gpf (13.2 Lpf) Closet	White
4.5 gpf (17.0 Lpf) Closet	White
3.5 gpf (13.2 Lpf) Urinal	White
2.4 gpf (9.0 Lpf) Closet	Blue

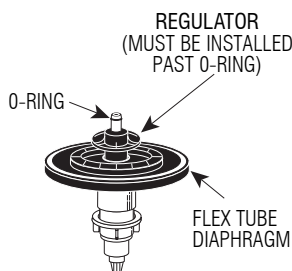

Notes: For a 4.5 gpf (17.0 Lpf) Water Closet flush, use the EBV-1020-A kit with the White Regulator. Cut and remove the A-164 Flow Ring from the Guide.

A 0.5 gpf (1.9 Lpf) Urinal kit can be converted to a 1.0 gpf (3.8 Lpf) by cutting and removing the smooth A-164 Flow Ring from the Guide.

RESS-C and RESS-U G2 Optima Plus valves are supplied with multiple Regulators to address multiple flushing applications. The product is shipped with it's lowest flush volume configuration. To convert the flush to a higher flushing volume, simply change the Regulator.

When installing a new Regulator on a Flex Tube Diaphragm Kit, be sure to push the Regulator past the O-ring when Installing.

Note: Never use more water than needed. Low Consumption water closets and urinals will not function properly on excess water.

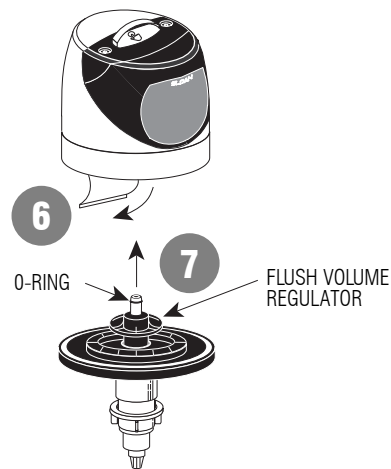

- 6 Remove Tab.
- 7 Make sure Flush Volume Regulator is installed past O-ring. Insert metal end of Flex Tube Diaphragm Assembly into hole at the base of the Sensor Module. O-ring must be fully inserted into hole.



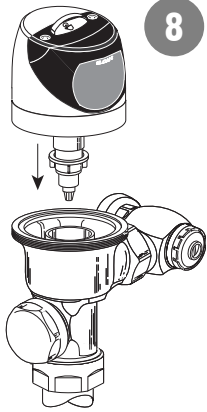

8 Install Assembly onto the Flushometer Valve Body. Lens must face directly forward.

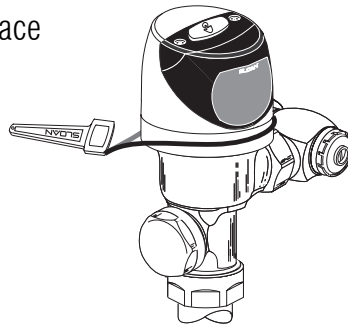

9 Tighten with Strap Wrench.

10 Pull Tab to activate.

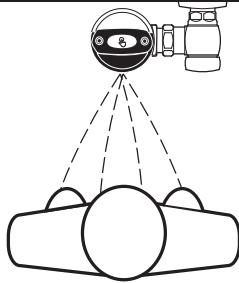
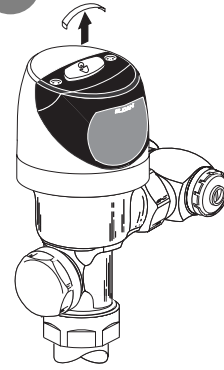

11 Test Sensor by standing in front of Sensor for Ten (10) Seconds.

Click ((

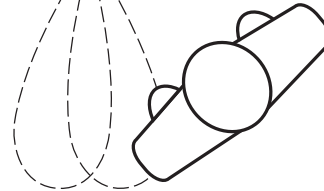

12 Step away from Sensor and listen for "CLICK."

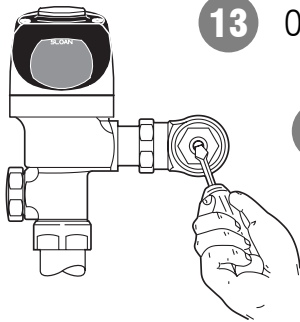

13 Open Control Stop (counterclockwise) 1/2 turn from closed position.

14 Place hand over lens for 10 seconds or press override button to activate.

15 Adjust Control Stop to meet the flow rate requirement for proper cleansing of the fixture.

16 Install Control Stop Cap.

Activate Flushometer and adjust Control Stop after each flush until rate of flow delivered properly cleanses the fixture. The Control Stop should never be opened to the point where the flow from the valve exceeds the flow capability of the fixture. In the event of a valve failure, the fixture must be able to accommodate a continuous flow from the valve.

GO

17 Test your Flushometer!

Range adjustment is factory set and typically does not require adjustment.

If range adjustment is required, refer to the Installation Instructions furnished with the G2 Optima Plus Flushometer.

The information contained in this document is subject to change without notice.

any questions



- We recommend that you review our G2 OPTIMA Plus Installation Instruction Manual and Maintenance Guides for complete instructions including Rough-in Dimensions, Specifications, Troubleshooting Guide, and Replacement Parts.
- Call our Installation Engineers for additional information at 1-800-9-VALVE-9 or fax them at 1-800-737-3061.

SLOAN

AIR DELIGHTS, INC. • 9974 SW ARCTIC DR. • BEAVERTON, OR. 97005
 Phone: 1-800-440-5556 or 1-503-352-1201 • Fax: 1-503-643-8224 • <http://www.airdelights.com>
 Copyright © 2003 Sloan Valve Company • Printed in the U.S.A. • Made in the U.S.A. • 0816455 — Rev. 0 (05/03)