

# SLOAN®

## INSTALLATION INSTRUCTIONS OPTIMA™ SYSTEMS SENSOR OPERATED HAND WASHING FAUCETS

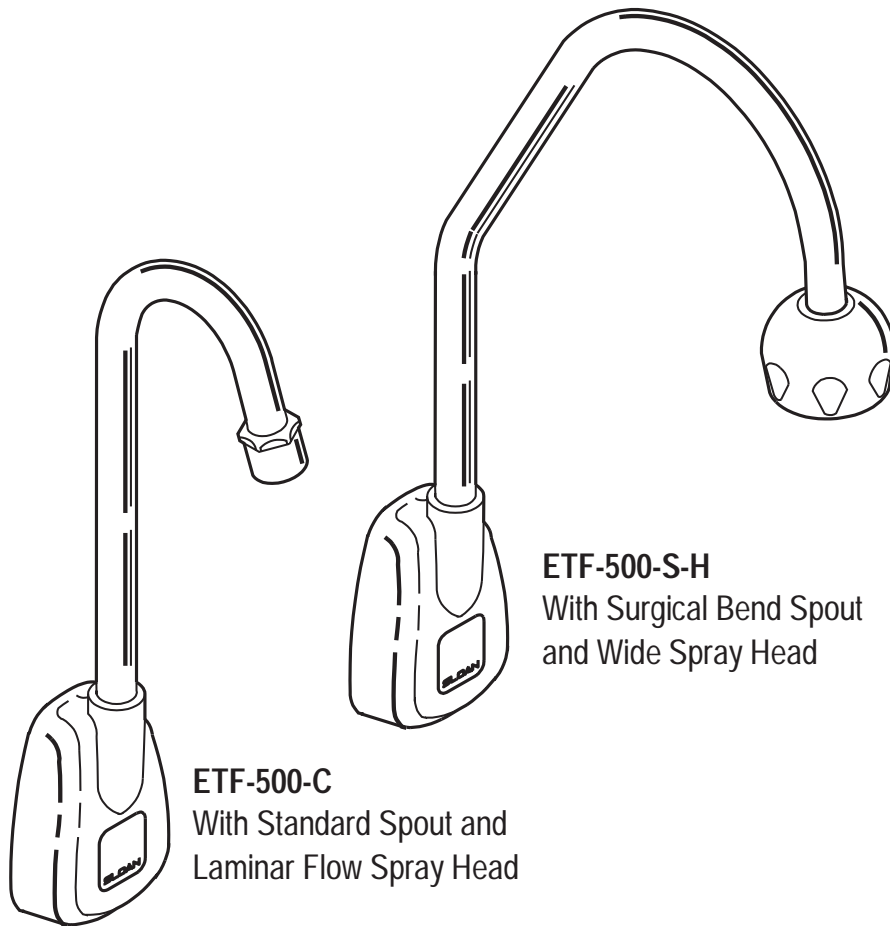

**ETF-500-C**  
With Standard Spout and  
Laminar Flow Spray Head

**ETF-500-S-H**  
With Surgical Bend Spout  
and Wide Spray Head

**ETF-500 Series**  
Wall-Mounted  
Sensor Operated  
Hand Washing Faucets  
with Gooseneck Spout

Includes Instructions for  
Installation of Optional Back  
Checks

Made in the U.S.A.

ANSI/ASME A112.18.1M



Installation of the Sloan OPTIMA™ Series Faucets makes scrub or wash-up sinks totally “hands-free” providing the ultimate in sanitary protection and automatic operation. The OPTIMA Series faucet uses infrared technology to sense the user’s presence and turn on a water supply that has been pre-mixed to the desired water temperature. When the user’s hands are removed from the invisible beam of light, the water supply automatically turns off.

The unique modular plug-in system is designed for ease of installation on new as well as retrofit applications. Sloan ETF-500 sensor operated faucets come complete with an integral faucet and sensor assembly, 24 VAC transformer,

solenoid valve, plug-in connection box (control module) and all mounting hardware. Back checks, a grid strainer and a mixing valve are also available and can be supplied as optional equipment. 3/8 inch copper supply tube or flexible hose connecting to be supplied by the installer.

The following instructions will serve as a guide when installing the Sloan OPTIMA Series faucet. As always, good safety practices and care are recommended when installing your new faucet. If further assistance is required, contact your nearest Sloan Representative office or the Sloan Installation Engineering Department.

### LIMITED WARRANTY

Sloan Valve Company warrants its ETF-500 Series Faucets to be made of first class materials, free from defects of material or workmanship under normal use and to perform the service for which they are intended in a thoroughly reliable and efficient manner when properly installed and serviced, for a period of three years (1 year for special finishes) from date of purchase. During this period, Sloan Valve Company will, at its option, repair or replace any part or parts which prove to be thus defective if returned to Sloan Valve Company, at customer’s cost, and this shall be the sole remedy available under this warranty. No claims will be allowed for labor, transportation or other incidental costs. This warranty extends only to persons or organizations who purchase Sloan Valve Company’s products directly from Sloan Valve Company for purpose of resale.

**THERE ARE NO WARRANTIES WHICH EXTEND BEYOND THE DESCRIPTION ON THE FACE HEREOF. IN NO EVENT IS SLOAN VALVE COMPANY RESPONSIBLE FOR ANY CONSEQUENTIAL DAMAGES OF ANY MEASURE WHATSOEVER.**

## FAUCET ROUGH-IN

### ETF-500 FAUCET WITH HOT AND COLD WATER SUPPLY (SHOWN WITH STANDARD SPOUT AND SHOWER SPRAY HEAD)

MODEL ETF-500-A-2 — 0.5 gpm (1.9 Lpm) Max.

MODEL ETF-500-B-2 — 2.2 gpm (8.3 Lpm) Max.

MODEL ETF-500-C-2 — 2.2 gpm (8.3 Lpm) Max. — Laminar Flow

MODEL ETF-500-H-2 — 2.2 gpm (8.3 Lpm) Max. — Shower Spray Head

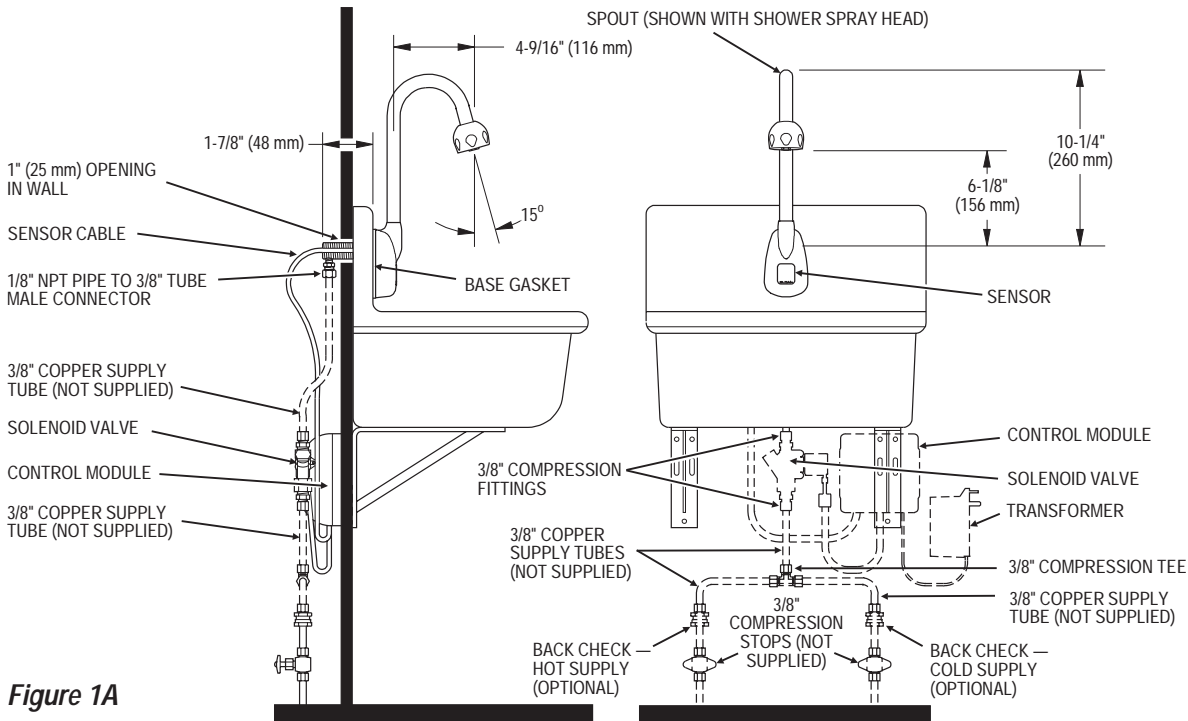

Figure 1A

### ETF-500 FAUCET WITH SINGLE LINE WATER SUPPLY (SHOWN WITH SURGICAL BEND SPOUT AND SHOWER SPRAY HEAD)

MODEL ETF-500-S-A — 0.5 gpm (1.9 Lpm) Max.

MODEL ETF-500-S-B — 2.2 gpm (8.3 Lpm) Max.

MODEL ETF-500-S-C — 2.2 gpm (8.3 Lpm) Max. — Laminar Flow

MODEL ETF-500-S-H — 2.2 gpm (8.3 Lpm) Max. — Shower Spray Head

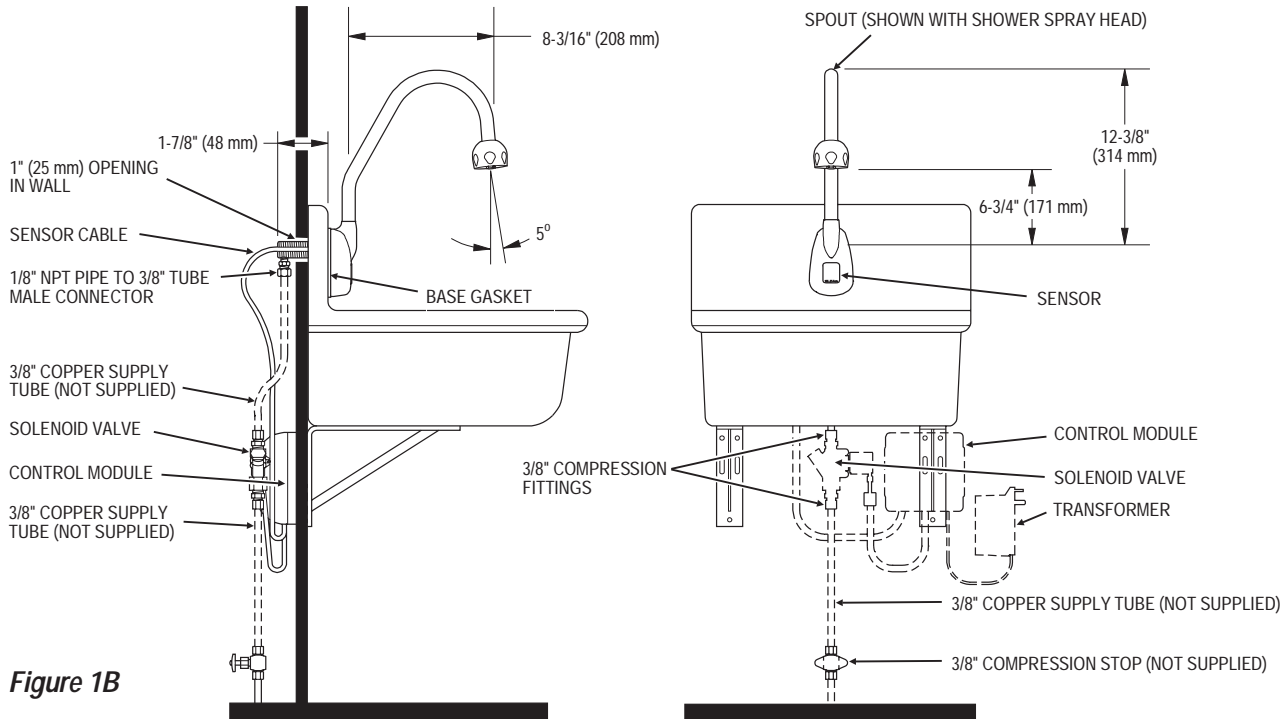

Figure 1B

## PRIOR TO INSTALLATION

Prior to installing the Sloan OPTIMA Series Faucet, install the items listed below. Also, refer to Figures 1A and 1B.

- **When Using Plug-In Transformer** — Install electrical receptacle for plug-in transformer — 120 VAC, 2 amp service for each ETF-233 (24 VAC, 35 VA) plug-in transformer used.
- **When Using Box Mount Transformer** — Install electrical wiring to the transformer location — 120 VAC, 2 amp service for each EL-248-40 (24 VAC, 40 VA) transformer used.
- Hot and cold water supply lines or tempered water supply line
- Scrub or wash-up sink
- Drain line

## Multiple Faucets

Multiple faucets can be powered by a single transformer, provided that the transformer has been properly sized. Allow a minimum of 15 VA of current rating for each solenoid valve used. See "Step 5 — Transformer" for further information.

## Mixing Valve

When installing the faucet with the Sloan MIX-25-A or MIX-30-A mixing valve, these Installation Instructions AND the Installation Instructions packaged with the mixing valve MUST be followed.

### Important:

- ALL ELECTRICAL WIRING SHOULD BE INSTALLED IN ACCORDANCE WITH NATIONAL/LOCAL CODES AND REGULATIONS.
- ALL PLUMBING SHOULD BE INSTALLED IN ACCORDANCE WITH APPLICABLE CODES AND REGULATIONS.
- A 24 VAC STEP-DOWN TRANSFORMER MUST BE USED.
- USE APPROPRIATE PRECAUTIONS WHILE CONNECTING TRANSFORMER TO 120 VAC POWER SOURCE.
- DO NOT PLUG TRANSFORMER INTO POWER SOURCE (RECEPTACLE) UNTIL ALL WIRING IS COMPLETED. ALLOWING 24 VAC TRANSFORMER WIRES TO TOUCH OR SHORT WHILE POWER IS BEING SUPPLIED WILL CAUSE PERMANENT DAMAGE TO THE TRANSFORMER AND CIRCUIT CONTROL MODULE.
- FLUSH ALL WATER LINES UNTIL WATER IS CLEAR BEFORE CONNECTING SOLENOID TO SUPPLY STOPS.

## TOOLS REQUIRED FOR INSTALLATION OF FAUCETS

- Open end wrenches for hex sizes (inches): 1/2, 5/8, 11/16, 15/16, 1-3/16
- Basin wrench
- Slotted screwdriver, 3/16"
- Phillips head screwdriver, #2
- Wire stripper/crimping tool
- Pipe Wrench
- Slotted screwdriver (supplied)
- Pliers

## INSTALLATION OF ETF-500 FAUCET

The Sloan OPTIMA ETF-500 Sensor Operated Gooseneck Faucet is a pre-tempered faucet. A pre-tempered water supply line or a mixing valve (ordered separately or supplied by others) must be used in conjunction with the faucet. When connecting the faucet to a hot and cold water supply, it is recommended that two back checks be installed as shown in Figure 1A. Water temperature can be controlled by adjusting the supply stops. When connecting the faucet to a single line water supply or a pre-tempered water supply, a back check is not required.

Back checks are required if the faucet is being installed with a Sloan MIX-25-A or MIX-30-A mixing valve.

## Flow Rate

The ETF-500-H faucet with a shower spray head incorporates a 2.2 gpm (8.3 Lpm) maximum flow control. If water flow is too forceful, reduce flow to faucet by adjusting supply stops. If a pressure reducing valve has been installed, adjust valve until optimum spray is obtained. Best performance is obtained between 25 and 40 psi.

## Step 1 — Install Back Checks (Option) (Figure 2)

The Sloan Back Check is designed to install on a 3/8" Compression Stop. If the existing Stop is different, the Stop may require replacement or additional fittings (not supplied by Sloan) to connect the Back Checks to the hot and cold water supply lines.

After flushing the water supply lines through the Stops, use a compression nut and compression sleeve to connect inlet end of Back Check to the Supply Stop. Tighten Securely.

**Note:** Failure to install the Back Checks on a double supply faucet can result in a cross flow connection when the faucet is in the off position and the supply stops are open if the pressure between the two lines is slightly different. This can cause a migration of hot water into the cold water supply, or cold water into the hot water supply. Most plumbing codes require that the Back Checks be used to prevent this occurrence.

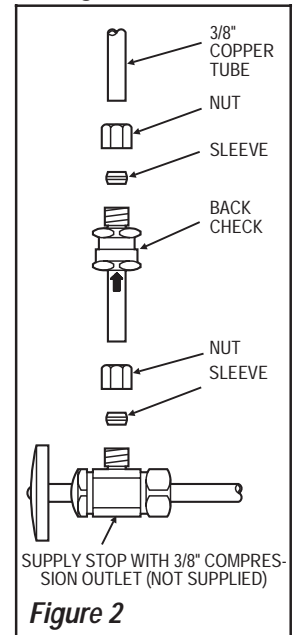

## Step 2 — Install Faucet Assembly (Figures 3A, 3B and 3C)

**Note:** If installing with the MIX-30-A Mixing Valve, install Mixing Valve prior to installing Faucet. Refer to the "Installation Instructions for MIX-25-A and MIX-30-A Mixing Valves" supplied with the Sloan mixing valve.

**TO MOUNT ON A SURFACE LESS THAN 0.41" (10 mm) THICK (FIGURE 3A):**

Route Faucet Cable through groove on side of Spout Shank. Insert Faucet Cable and Spout Shank through Base Gasket and then through the mounting hole of scrub or wash-up sink. Secure using the Flat Washer, Lockwasher and Nut

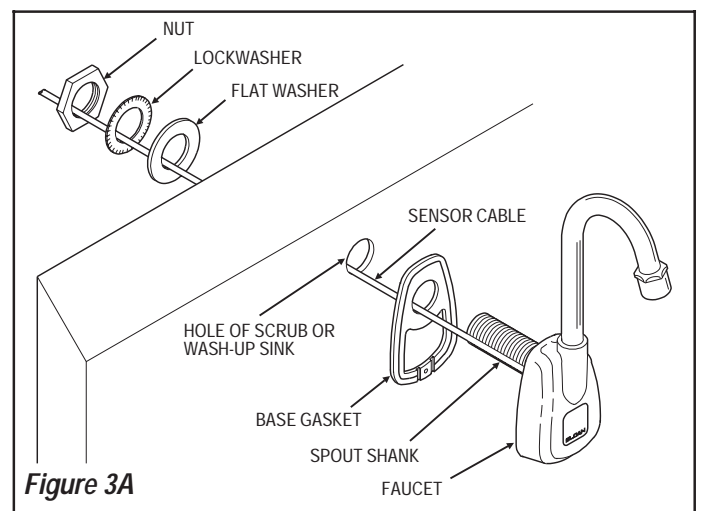

**TO MOUNT ON A SURFACE BETWEEN 0.41" (10 mm) AND 1" (25 mm) THICK (FIGURE 3B):**

Insert Mounting Stud into hole on the back side of the Spout Shank. Route Faucet Cable through groove on side of spout shank. Insert Faucet Cable and Spout Shank with attached Mounting Stud through the Base Gasket and then through the mounting hole of scrub or wash-up sink. Last, insert it through the larger hole of the Mounting Spacer. Press the flat side of the Mounting Spacer against the back side of the mounting surface. The Mounting Stud should protrude through the smaller hole of the Mounting Spacer. Secure using the Flat Washer, Lockwasher and Hex Jam Nut supplied. Do **NOT** overtighten the Hex Jam Nut.

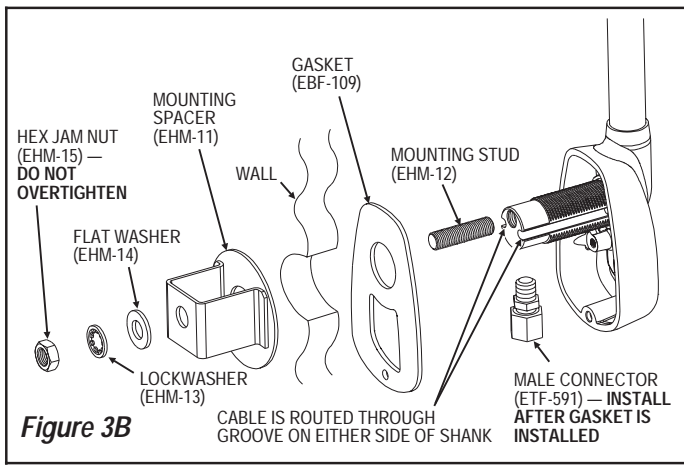

**Figure 3B**

**Note:** Sloan Valve Company does NOT supply hardware necessary for mounting the faucet on surfaces thicker than 1" (25 mm) thick.

**OPTIONAL ANTI-ROTATION FEATURE (FIGURE 3C)**

**Note:** The anti-rotation feature uses a screw to anchor the faucet in the vertical position and is intended for use ONLY on stainless steel sinks.

Use the faucet Base Gasket as a template by placing it in position over the faucet mounting hole. Mark the stainless steel mounting surface at the center of the small hole at the bottom of the Base Gasket. Drill a 7/64" (3 mm) diameter hole through the stainless steel mounting surface. Insert the Self-Tapping Screw from the back through the drilled hole. Tighten the Screw until it securely engages into the small hole in the back of the faucet body to prevent rotation from the vertical mounting position.

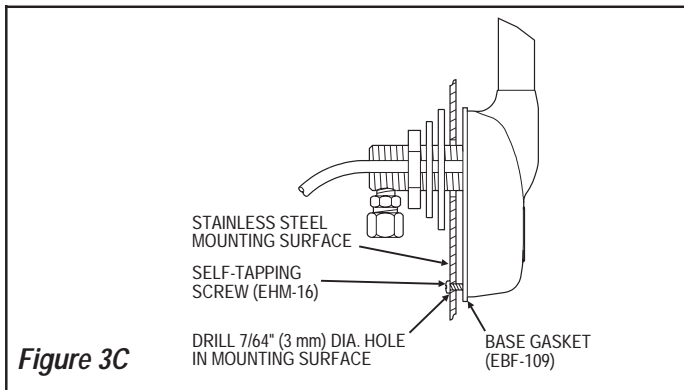

**Figure 3C**

**Step 3 — Install Solenoid Valve (Figures 4, 5 and 6)**

Apply thread sealant or Teflon tape to threads of 3/8 inch Compression Fittings. Install 3/8 inch Compression Fittings to inlet and outlet sides of Solenoid Valve.

**Note:** Flow direction of Solenoid Valve is indicated by an arrow on Valve Body.

**Important:** When applying any form of sealant to fitting threads, leave the first two starter threads free of sealant to prevent the possibility of sealant entering into the waterway and damaging system components.

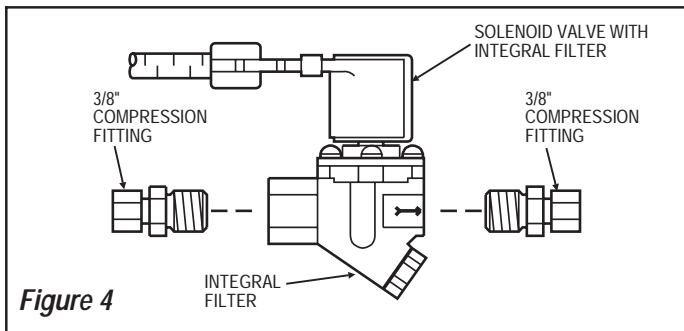

**Figure 4**

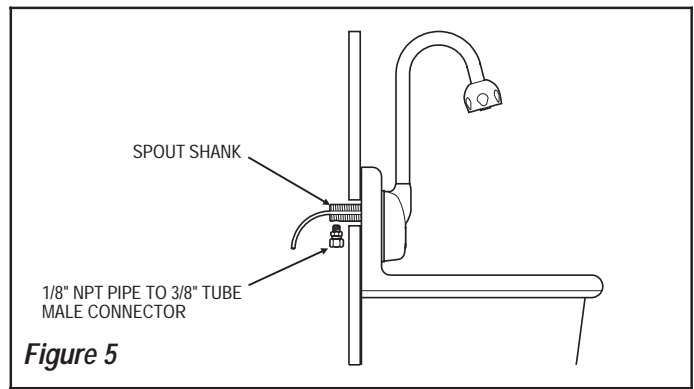

**Figure 5**

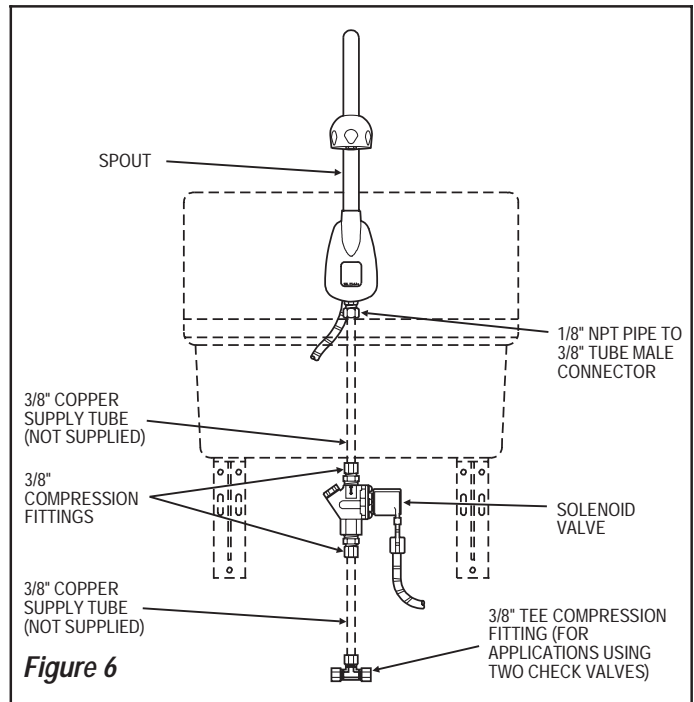

**Figure 6**

Thread Male Connector into inlet hole at bottom of Spout Shank; tighten securely to prevent leaks.

Connect a 3/8" O.D. copper supply tube (furnished by the installer) between Compression Fittings on Spout and top outlet of Solenoid Valve.

**Important:** DO NOT install solenoid so that the solenoid coil is facing down. The solenoid valve may be oriented so that the solenoid coil faces sideways (vertically); however, optimum performance is obtained when solenoid valve is in the horizontal position with the solenoid coil facing up as shown in Figure 4.

**Step 4 — Connect Supply Line(s) (Figures 1A and 1B)**

**Note:** If installing the Sloan mixing valve, refer to the "Installation Instructions for MIX-25-A and MIX-30-A Mixing Valves" supplied with the Sloan mixing valve.

Flush supply line(s) of any debris.

**FOR HOT AND COLD WATER SUPPLY APPLICATIONS**

When connecting the Faucet to a hot and cold water supply, two Back Checks are required as shown in Figure 1A.

Insert tube end of Back Checks into 3/8 inch Compression Fitting of hot and cold Supply Stops. (Supply Stops furnished by installer.) Tighten Compression Fittings securely.

Install a 3/8 inch copper Supply Tube between each Back Check and the Compression Tee Fitting supplied (refer to Figure 1A).

Install a 3/8 inch copper Supply Tube between Compression Tee Fitting and inlet side of Solenoid Valve.

## FOR SINGLE LINE WATER SUPPLY APPLICATIONS

When connecting the Faucet to a single line water supply or a pre-tempered water supply, a Back Check is not required.

Install a 3/8 inch copper Supply Tube between the Supply Stop and inlet side of Solenoid Valve (refer to Figure 1B). (Supply Stops furnished by installer.)

Refer to Figures 1A and 1B — Faucet Rough-In for Additional Information.

## Step 5 — Transformer

### Multiple Faucets

Multiple faucets can be powered by a single transformer, provided that the transformer has been properly sized. Allow a minimum of 15 VA of current rating for each solenoid valve used. Refer to the following example to determine the required current rating for 3 OPTIMA faucets.

#### Example:

Total number of OPTIMA faucets	3
Total number of solenoid valves	3
Multiply by current rating	15 VA
Minimum current rating of required transformer	45 VA

### Transformers Supplied with the ETF-500 Faucets

Standard Plug-In *	ETF-233	120 VAC	35 VA
Standard Box Mount	EL-248-40	120 VAC	40 VA

\* In Canada, use ETF-416 (120 VAC, 35 VA).

### Optional Transformers Available from Sloan

Box Mount	EL-154	120 VAC	50 VA
Foot Mount	EL-208	120 VAC	100 VA
Box Mount	EL-342	240 VAC	50 VA

All Sloan transformers are 50/60 Hz.

Other transformers (not supplied by Sloan) may be used provided they meet UL requirements for Class 2 transformers.

### PLUG-IN TRANSFORMER (Figures 7, 8 and 9)

**Important: DO NOT plug Transformer into receptacle until all wiring has been completed.**

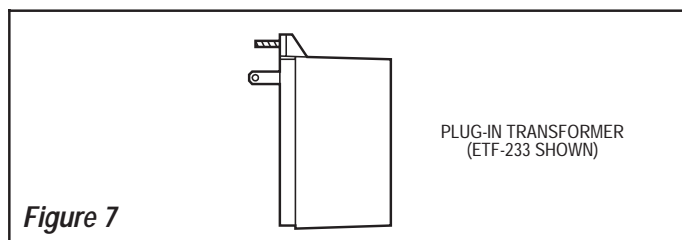

This type of Transformer is designed to be plugged into a 120 VAC wall receptacle. The Transformer is supplied with a 10 foot Cable; however, this Cable can and should be shortened to meet installation requirements.

Separate and strip one end of Transformer Power Cable approximately 3/16 to 1/4 inch (5 to 6 mm). Install Transformer Strain Relief 3 inches (76 mm) from stripped end of Power Cable. Squeeze Strain Relief with a pliers and insert Power Cable and Strain Relief into 3/8 inch (10 mm) hole at back of Control Module as shown in Figure 8. Always install right angle Strain Relief so that Power Cable enters the Control Module from the bottom. Connect Power Cable to Terminal Block on Connector Board as shown in Figure 11.

**Important: Twist stranded ends of Power Cable before inserting into Terminal Block. Fraying of Stranded Power Cable Wire can cause a short and damage the Control Module and Transformer when powered.**

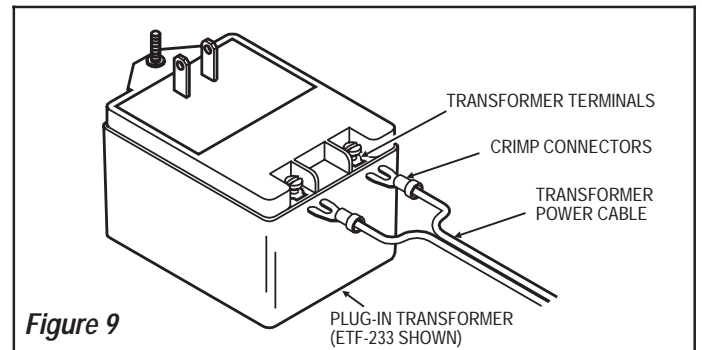
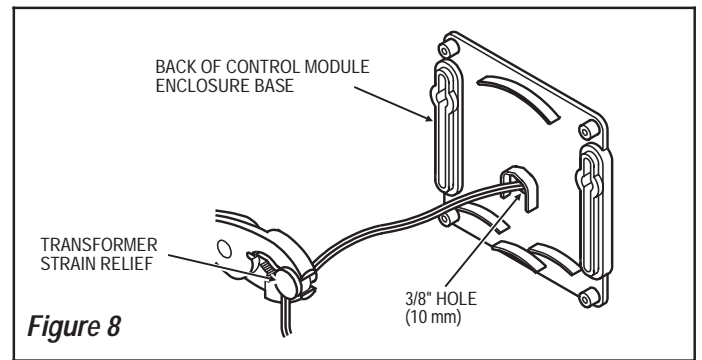

Install Crimp Connectors to opposite end of Transformer Power Cable and connect Power Cable ends to Transformer Terminals as shown in Figure 9.

### BOX MOUNT TRANSFORMER (Figure 10)

**Important: DO NOT supply power to primary side of Transformer until all wiring has been completed.**

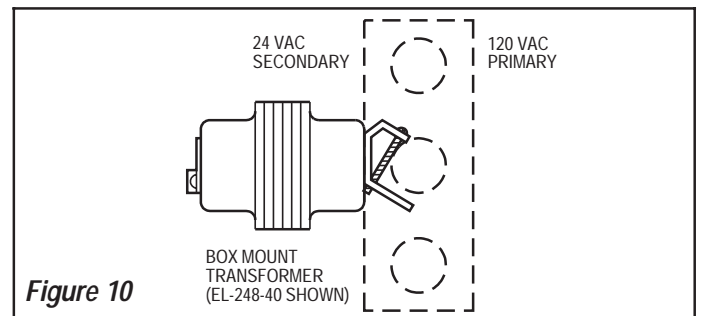

This type of Transformer is designed to be mounted on a metal electrical junction box (supplied by others). ("J" box should be mounted inside chase wall or above ceiling.) Install Transformer within 50 feet (15.24 meters) of Faucet. 18 gauge wire is recommended.

Run wires from secondary side of Transformer to 3/8 inch (10 mm) hole at back of Control Module Enclosure. If necessary, wires can be run through wall and inserted through hole in back of Control Module Enclosure.

### Step 6 — Mount Control Module to Wall (Figures 1 and 11)

Install the Control Module in an appropriate location as shown in Figures 1A and 1B. Control Module must be installed so that all cables enter from the bottom of the unit. When installed, Cables from the Sensor and Solenoid Valve to the Control Module should have some slack.

Mount Control Module to wall using Mounting Screws and Plastic Anchors.

### EXTENSION CABLES

Extension Cables are available as an option from Sloan for installation of the Control Module remote from the Sensor and Solenoid Valve. Cables can be supplied in lengths of 3 feet (0.9 meter), 6 feet (1.8 meters) and 9 feet (2.7 meters).

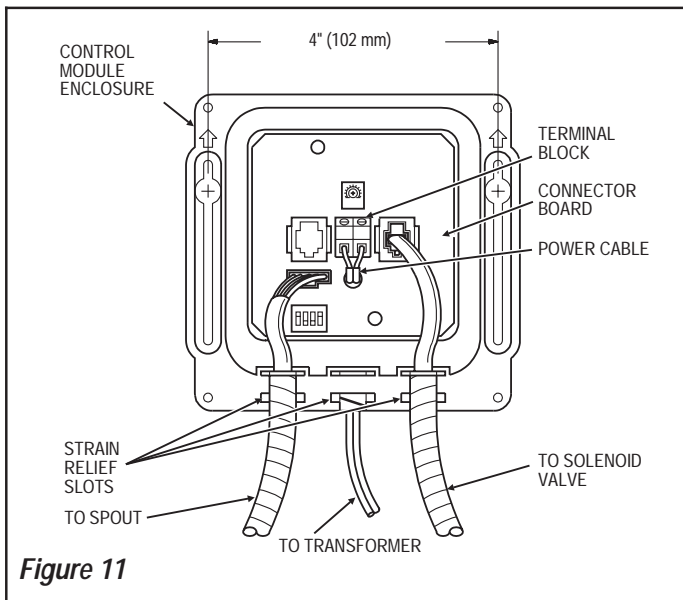

### Step 7 — Control Module Connection (Figures 11 thru 13)

Route Cables from Solenoid Valve and Spout to the location where Control Module is mounted (usually centered between Spout and Solenoid Valve to ensure enough slack in all Cables).

Insert Solenoid Valve Connector into a Modular Receptacle on Connector Board. Solenoid Receptacles are interchangeable allowing Connectors to be inserted into either Receptacle. Insert Locking Connector from Spout into mating Receptacle on Connector Board. Allow 3 to 4 inches (76 to 102 mm) of Cable to extend into the Control Module.

Insert each Conduit Cable into a strain relief slot in the Control Module.

Refer to Figures 1A and 1B — Faucet Rough-In for additional information.

### Step 8 — Start-Up

Supply power to transformer.

**Note:** The Control Module is equipped with two LED lights. When the Board is being powered by the Transformer, one LED will illuminate green. When the Sensor is activated, this LED will change to red. A second red LED illuminates when the Solenoid Valve is activated. Refer to Figure 12.

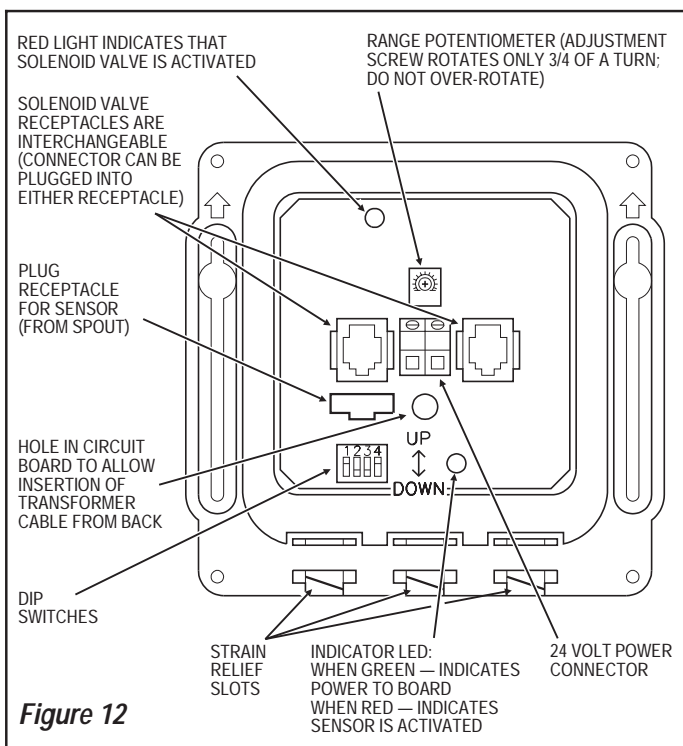

Figure 12

Open Supply Stops. With Spray Head removed, activate Faucet for 30 seconds by placing hands in front of Sensor. The Solenoid Valve should “click” and water should flow from the Spout. If this does not occur, refer to the Troubleshooting section of this instruction manual.

Close Supply Stops and install Spray Head in Spout and tighten securely. Reopen Supply Stops, activate Faucet and check for leaks.

### Step 9 — Range Adjustment

The OPTIMA Series Faucet is factory set to operate at a range of 8 to 10 inches (203 to 254 mm). This range should be satisfactory for most installations.

If range adjustment is required, refer to the following procedures.

#### TO MAKE A RANGE ADJUSTMENT

The Range Potentiometer and Dip Switches are located in the Control Module as shown in Figure 12.

**Important:** Range Potentiometer adjustment screw rotates only 3/4 of a turn; DO NOT over-rotate.

Make certain that Dip Switch number 4 is in the DOWN position. Using the small screwdriver provided, turn the potentiometer a few degrees:

Clockwise to INCREASE range

Counterclockwise to DECREASE range

Place hand in front of Sensor and move toward Sensor until “click” from Solenoid Valve is heard and water turns on.

Determine range by backing hand away from Sensor until water turns off.

Cycle Faucet several times to assure that range as adjusted will not inadvertently pick up IR reflection off the edge of the sink. If IR reflection occurs (green LED will flicker red), adjust Range Potentiometer counterclockwise very slightly and again cycle Faucet.

Repeat adjustment procedure until desired range is obtained.

**Note:** Sensitivity can be reduced by switching Dip Switch number 4 to the ON (UP) position.

#### Time Out Adjustment

The Faucet Time Out Setting determines the maximum length of time the Faucet will run upon continuous activation. This timing can be changed to meet individual application requirements.

Refer to the label on cover of Control Module along with the following instructions to set the desired Time Out. The Dip Switches used to set the Time Out are located in the Control Module as shown in Figure 12.

Set the Time Out by configuring the number 1, 2 and 3 Dip Switches as follows:

Table 1 — Time Out Settings

Time Out	Dip Switch Setting		
	Switch # 1	Switch # 2	Switch # 3
3 SECONDS	UP	UP	DOWN
6 SECONDS	DOWN	DOWN	UP
12 SECONDS	UP	DOWN	UP
30 SECONDS	UP	DOWN	DOWN
45 SECONDS	UP	UP	UP
1 MINUTE	DOWN	UP	UP
3 MINUTES	DOWN	DOWN	DOWN
20 MINUTES	DOWN	UP	DOWN

Unless otherwise specified, all ETF-500 Faucets leave the factory set with a 30 second Time Out.

**Note:** The position of Dip Switch number 4 (range enhancer setting) does not affect Faucet Time Outs.

Push Cables into slots at the bottom of the Circuit Box.

Install Control Module cover using all four (4) Screws provided (Figure 13).

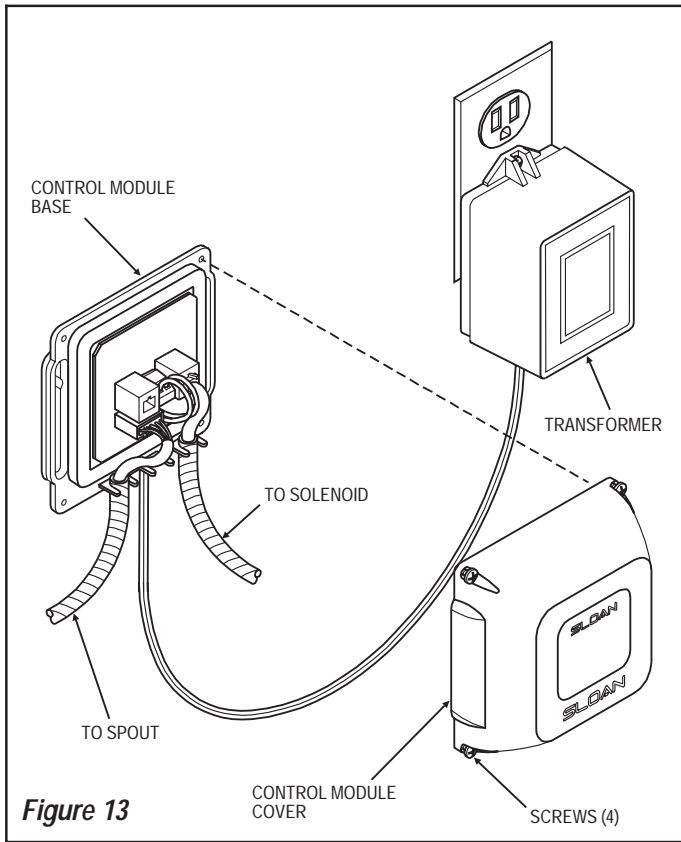
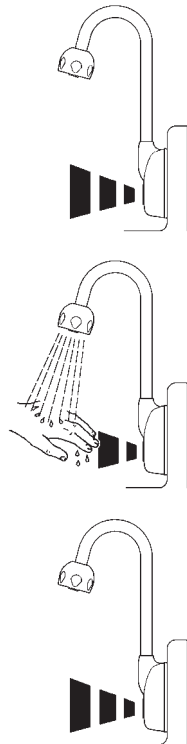

Figure 13

## OPERATION

1. A continuous invisible beam of infrared light is emitted from the sensor located on the base of the faucet.
2. As the user's hands enter the beam's effective range (beneath the aerator or spray head), the beam is reflected back into the sensor receiver and activates the solenoid valve. Tempered water flows from the faucet into the sink until the hands are removed from the beam or until the faucet reaches its automatic time out limit setting.
3. When hands are moved away from the sensor, the loss of reflected light initiates an electrical signal that deactivates the solenoid valve, shutting off the water flow. The circuit then automatically resets and is ready for the next user.



## CARE AND CLEANING OF CHROME AND SPECIAL FINISHES

DO NOT use abrasive or chemical cleaners (including chlorine bleach) to clean faucets that may dull the luster and attack the chrome or special decorative finishes. Use ONLY soap and water, then wipe dry with clean cloth or towel.

While cleaning the bathroom tile, protect the faucet from any splattering of cleaner. Acids and cleaning fluids will discolor or remove chrome plating.

## TROUBLESHOOTING GUIDE

PROBLEM	POSSIBLE CAUSE/SOLUTION
<b>No water when activated</b> Open control module and check diagnostic lights.	<ul style="list-style-type: none"> <li>• <b>If no lights are illuminated:</b> <ol style="list-style-type: none"> <li>1. Make certain that main power is turned "ON." Check receptacle, transformer, solenoid, leads and connections.</li> <li>2. Control module circuit board is faulty; replace.</li> </ol> </li> <li>• <b>If green LED is illuminated and turns red when hands are placed under faucet:</b> <ol style="list-style-type: none"> <li>1. Check Supply Stop(s); open if closed.</li> <li>2. Debris in filter; remove, clean and reinstall.</li> </ol> </li> <li>• <b>If green/red LED is red and red LED does not illuminate:</b> <ol style="list-style-type: none"> <li>1. Sensor range is too long (picking up sink); reduce range.</li> <li>2. Sensor is faulty; replace sensor module.</li> </ol> </li> <li>• <b>If green LED is illuminated and does not turn red when hands are placed under faucet:</b> <ol style="list-style-type: none"> <li>1. Sensor range is too short; increase range.</li> <li>2. Sensor is faulty; replace sensor module.</li> </ol> </li> </ul>
<b>Very low flow or slow dribble</b>	<ul style="list-style-type: none"> <li>• Check Supply Stop(s); open if closed.</li> <li>• Disassemble solenoid; clean and flush.</li> <li>• Debris is in filter; remove, clean and reinstall.</li> <li>• Debris is in aerator or spray head; remove, clean and reinstall.</li> </ul>
<b>False triggering (unit goes on by itself)</b>	<ul style="list-style-type: none"> <li>• Range is too long; decrease detection zone. Check surroundings for factors that can contribute to range detection problems; for example, bright lights, highly reflective surfaces, sunlight, etc.</li> </ul>
<b>Continues to run (even after power to faucet has been disconnected)</b>	<ul style="list-style-type: none"> <li>• Solenoid valve is installed backwards.</li> <li>• Debris is in solenoid, won't close properly; remove operator and clean. Reassemble in the same manner.</li> </ul>
<b>Temperature too hot or too cold (faucet supplied with two back checks)</b>	<ul style="list-style-type: none"> <li>• Supply Stops are not adjusted properly; adjust Supply Stops.</li> <li>• One Back Check may be installed backwards; correct. If required, use thermostatic mixing valve.</li> </ul>

If further assistance is required, please contact the Sloan Valve Company Installation Engineering Department at 1-800-982-5839.

## PARTS LIST

### COMPONENTS SUPPLIED WITH FAUCET

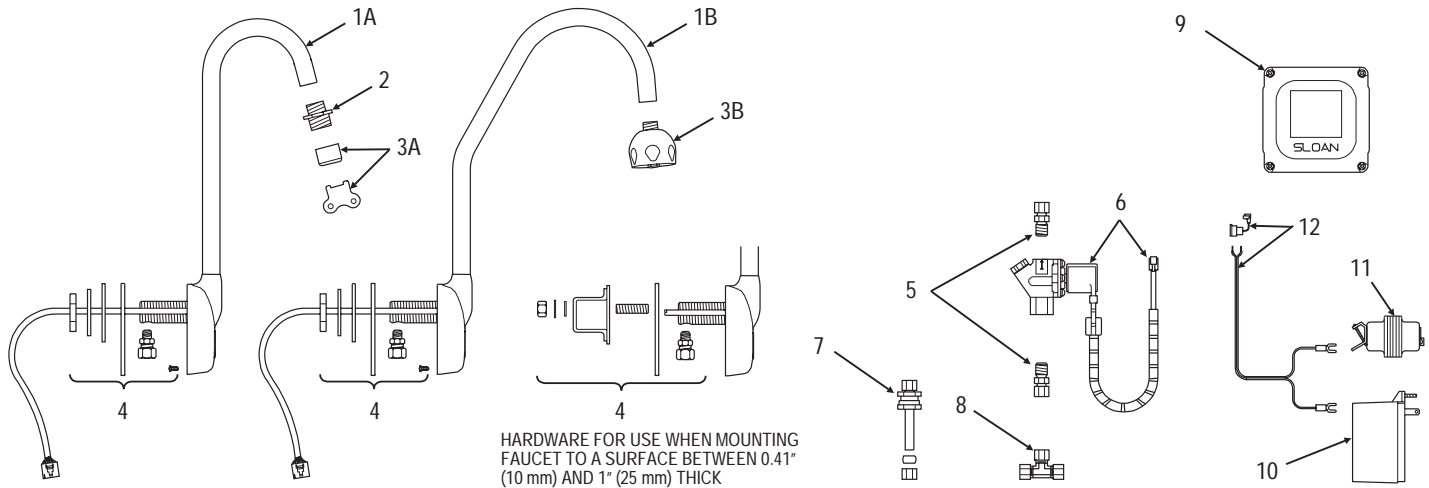

HARDWARE FOR USE WHEN MOUNTING  
FAUCET TO A SURFACE BETWEEN 0.41"  
(10 mm) AND 1" (25 mm) THICK

Item No.	Part No.	Description
<b>COMPONENTS SUPPLIED WITH FAUCET</b>		
1A	ETF-561-A	Faucet/Sensor Assembly, Standard (ETF-500)
1B	ETF-564-A	Faucet/Sensor Assembly with Surgical Bend (ETF-500)
2	ETF-178	Aerator Adapter (not required for Shower Spray Head)
3A	ETF-1021-A	Spray Head with Mounting Key, 0.5 gpm (1.9 Lpm)
	ETF-1022-A	Aerator Spray Head with Mounting Key, 2.2 gpm (8.3 Lpm)
	ETF-237	Laminar Flow Spray Head, 2.2 gpm (8.3 Lpm) (no Mounting Key Required)
3B	AC-55-A	Shower Spray Head, 2.2 gpm (8.3 Lpm)
4	EBF-110-A	Spout Mounting Kit, Includes: Base Gasket Flat Washer Lockwasher Mounting Nut 1/8" NPT x 3/8" Tube Male Connector Mounting Stud, 3/8"-24 Mounting Spacer Flat Washer, 3/8" Lockwasher, 3/8" Hex Jam Nut, 3/8"-24 Self-Tapping Screw, #6 x 3/8", Type B
5	ETF-437-A	Assembly Kit, Includes: Compression Fittings (2) Compression Nut (1) Compression Sleeve (1)
6	ETF-370-A	Solenoid Valve, 24 VAC, Includes Wire Harness
7	ETF-470-A	Back Check (2 Supplied When Specified with Faucet)
8	ETF-259	Tee Compression Fitting

Item No.	Part No.	Description
<b>COMPONENTS SUPPLIED WITH FAUCET (Continued)</b>		
9	ETF-450-A	Control Module Assembly
10	ETF-233	Plug-In Transformer
11	EL-248-40	Box Mount Transformer
12	ETF-458-A	Power Cable with Strain Relief and Crimp Connectors (Transformer to Control Module)

#### FAUCET CABLE EXTENSION CORDS (Not Shown)

##### Spout to Control Module

ETF-1005-36	3 Foot (0.9 meter) Length
ETF-1005-72	6 Foot (1.8 meter) Length
ETF-1005-108	9 Foot (2.7 meter) Length

##### Solenoid to Control Module

ETF-1003-36	3 Foot (0.9 meter) Length
ETF-1003-72	6 Foot (1.8 meter) Length
ETF-1003-108	9 Foot (2.7 meter) Length

#### SOLENOID VALVE REPAIR KIT

(Includes Replacement Filter)

ETF-1009-A

#### NOTICE

The information contained in this document is subject to change without notice.

# SLOAN

Copyright © 2000 Sloan Valve Company

AIR DELIGHTS, INC. • 9974 SW Arctic Drive • Beaverton, Or. 97005

Phone: 1-800-440-5556 • Fax: 1-503-643-8224

<http://www.airdelights.com>

Printed in U.S.A. 03-00