



# AMERICAN SPECIALTIES, INC.

441 Saw Mill River Road, Yonkers, NY 10701 (914) 476-9000

MODEL No: 9468

ISSUED: 1-87

REVISED: 9-04

## PROFILE COLLECTION RECESS MOUNTED DUAL SANITARY NAPKIN AND TAMPON DISPENSER (PG 1/2)

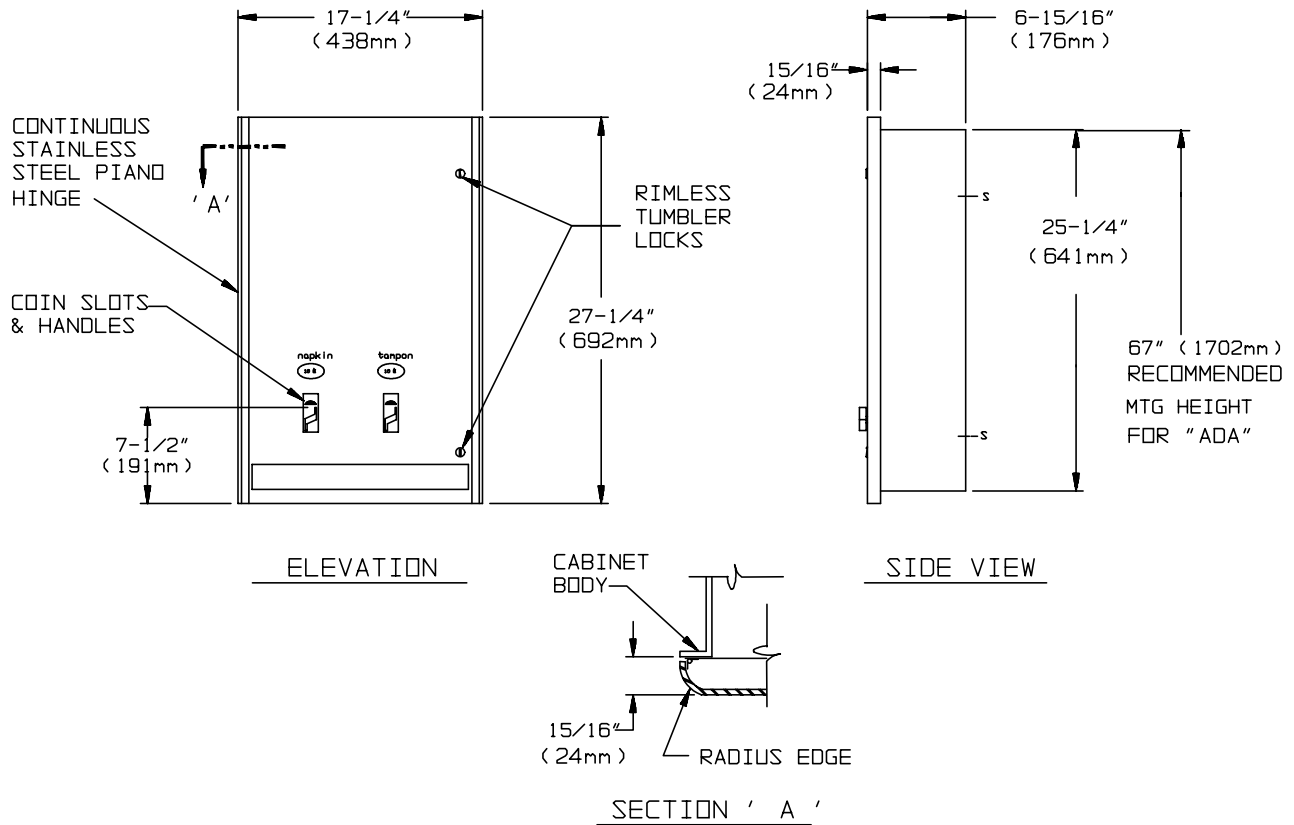

### SPECIFICATION

Profile Collection Recess Mounted Dual Sanitary Napkin & Tampon Dispenser shall hold 30 napkins and 27 tampons of specified sizes. Cabinet and door shall be fabricated of alloy 18-8 stainless steel, type 304. Cabinet shall be 20 gauge with a 1" (25mm) wide perimeter return to lay flat against wall. Full face door shall be 16 gauge and shall be free of miters, welding or open seams with 15/16" (24mm) square horizontal return to wall and 3/4" (19mm) rounded vertical edges. Door shall be attached to the edge of unit with a full length 3/16" (5mm) dia. stainless steel multi-staked piano hinge and shall be held closed with two (2) rimless tumbler locks keyed alike to other ASI washroom equipment. Internal coin-box shall be keyed differently than door locks. All exposed surfaces shall have N° 4 satin finish and shall be protected during shipment with a PVC film that shall be easily removable after installation. Dispensing mechanisms shall be fastener mounted internally to provide ability to change mechanisms for coinage denomination. Structural assembly of body and door components shall be of welded construction and have no exposed fasteners or welded seams. Weights for each feed track shall be supplied. Factory installed coin operation denomination shall be \_\_\_\_\_ (please fill in 25¢ or 50¢ or FREE) and add denomination as suffix to model N° (i.e. 9468-25)).

**Profile Collection Recess Mounted Dual Sanitary Napkin & Tampon Dispenser shall be Model N° 9468 as manufactured by American Specialties, Inc., 441 Saw Mill River Road, Yonkers, New York 10701- 4913**

### INSTALLATION

Unit is mounted in wall recess using four (4) N° 10 self-tapping screws (by others). For maximum usability and compliance with ADA Accessibility Guidelines, unit should be installed so that coin slot is between 54" (1372mm) maximum above finished floor (AFF) and 38" (965mm) minimum AFF. Note that coin slot is 6-3/8" (162mm) above bottom edge of RWO.

**Rough Wall Opening (RWO) required is..... 16"W x 26"H x 6-1/4"D (406mm x 660mm x 159mm)**



# AMERICAN SPECIALTIES, INC.

441 Saw Mill River Road, Yonkers, NY 10701 (914) 476-9000

MODEL No: 9468

ISSUED: 1-87

REVISED: 9-04

## PROFILE COLLECTION RECESS MOUNTED DUAL SANITARY NAPKIN AND TAMPON DISPENSER (PG 2/2)

### OPERATION

Deposit of specified coin allows operation of dispenser. Napkin and tampon dispensers operate independently. Selected product drops into vending opening after operator actuation. Indicator displays empty condition and blocks coin slot when product is depleted. Unit vend product supply is replenished on cycle determined by maintenance needs by opening door and manually reloading product into dispenser supply tracks. Track weights **MUST BE USED** to provide positive feed.

### NAPKINS, SINGLES, CARDBOARD-BOXED, SEMIGLOSS FINISH; CAPACITY: 30, BOX SIZE: 4-1/4" x 3" x 1-1/8" (108mm x 76mm x 29mm)

Stayfree	No. 4
Guards	No's. 247, or 147
Kotex	No's. 704, 707, 07010, 07040, 07045, 07300, 07320
Pure-Nat	No. M-4
Modess	No. 4

### TAMPONS, CYLINDER, CARDBOARD, SEMIGLOSS, CRIMPED ENDS; CAPACITY: 27, TUBE SIZE: 3/4" dia. x 5-1/4" (19mm x 134mm)

Tampax	
Modess Tampons	