



INSTALLATION INSTRUCTIONS FOR DECK MOUNT SENSOR ACTIVATED SOAP DISPENSER

SJS-1650

Sensor Activated
Soap Dispenser



For Soap Replenishment, use:

- | Sloan Part # | Description |
|--------------|----------------------------|
| SJS-1651-3 | Liquid Soap |
| SJS-1651-4 | Liquid Soap w/Moisturizers |

LIMITED WARRANTY

Sloan Valve Company warrants its SJS-1650 Electronic Soap Dispenser to be made of first class materials, free from defects of material or workmanship under normal use and to perform the service for which it is intended in a thoroughly reliable and efficient manner when properly installed and serviced, for a period of three years (1 year for special finishes) from date of purchase. During this period, Sloan Valve Company will, at its option, repair or replace any part or parts which prove to be thus defective if returned to Sloan Valve Company, at customer's cost, and this shall be the sole remedy available under this warranty. No claims will be allowed for labor, transportation or other incidental costs. This warranty extends only to persons or organizations who purchase Sloan Valve Company's products directly from Sloan Valve Company for purpose of resale. This warranty does not cover the life of the batteries.

THERE ARE NO WARRANTIES WHICH EXTEND BEYOND THE DESCRIPTION ON THE FACE HEREOF. IN NO EVENT IS SLOAN VALVE COMPANY RESPONSIBLE FOR ANY CONSEQUENTIAL DAMAGES OF ANY MEASURE WHATSOEVER.

PRIOR TO INSTALLATION

New Soap Dispenser Installation:

- Locate position of dispenser using templates shown in rough-in diagrams (refer to rough-in diagrams below)
- Ensure that dispenser does not interfere with anything above or below the lavatory/counter top area
- Drill a 1" diameter hole in counter top
- Clean area around hole

Replacing Existing Soap Dispenser:

- Remove old components
- Clean area around hole
- Ensure hole is 1" to 1-1/4" diameter

LOCATION

The SJS-1650 Soap Dispenser is designed to be mounted to the left or right of the faucet as shown below. When choosing a location, make sure that there will be accessibility to the unit on the underside of the sink (the Motor and Soap Container cannot interfere with the water or drain lines).

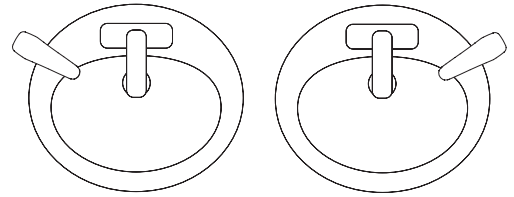

ROUGH-IN

Direct Connect Installation

Offset Installation

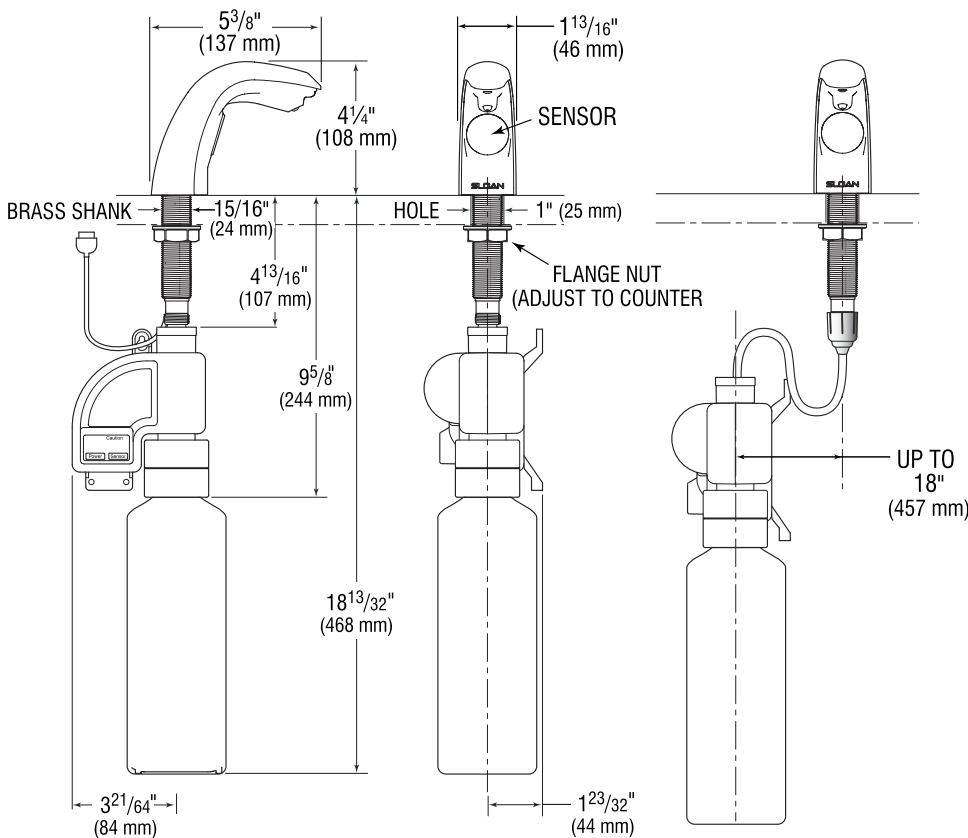

1 Install Spout

A Slide Rubber Gasket onto Brass Shank.

B Guide Brass Shank and Sensor Cord through hole in counter.

C Position Spout to direct soap into sink.

D Guide Sensor Cord through Flange Nut. Screw Flange Nut onto Brass Shank and tighten.

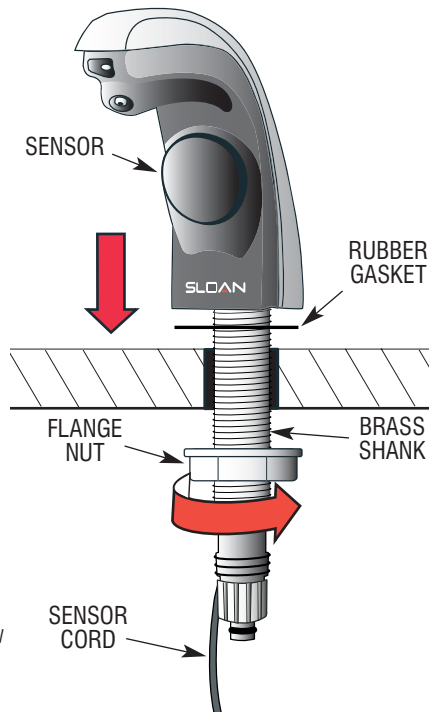

2 Mount Motor Assembly

!!! IMPORTANT !!!

Choose a location where there will be accessibility to the unit on the underside of the sink (the Motor and Soap Container cannot interfere with the water or drain lines). Before drilling holes in the wall, be sure that no other pipes or wires exist.

A Refer to the illustration below for mounting hole location.

B Using the Motor Assembly as a template, mark the mounting holes on wall. Make certain that the Motor Assembly is level.

- When mounting onto a concrete wall, drill holes 1/8" diameter and 11/32" or more in depth for wall anchors.
- When mounting onto a wood panel, drill pilot holes 3/32" diameter in advance.

Note: Completely remove Clip from Motor Assembly Outlet.

C Align the Motor Assembly with the mounting holes and secure with the 3 stainless steel screws (included).

Note: The Assembly Box must be mounted vertically as shown.

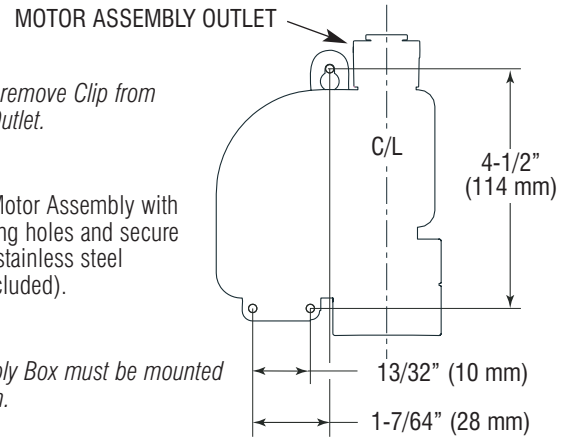

5 Attach Tube to Faucet Shank

A Slide Tube Connector onto Flexible Tube. Insert Tube Fitting into end of Flexible Tube.

Important: Make sure O-rings are in place.

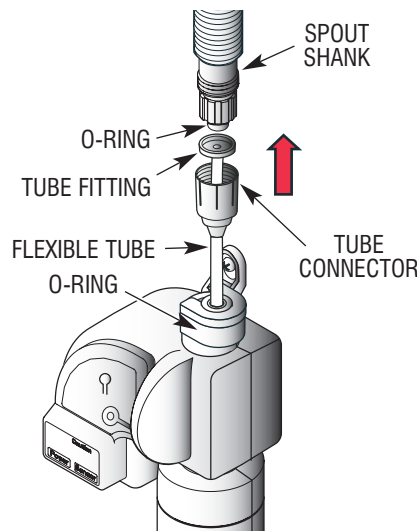

B Screw Tube Connector onto Spout Shank and tighten.

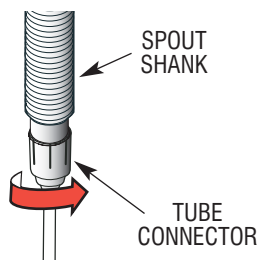

6 Insert Soap Bottle into the Motor Assembly

A Remove Soap Bottle Cap.

B Place Soap Bottle into Motor Assembly

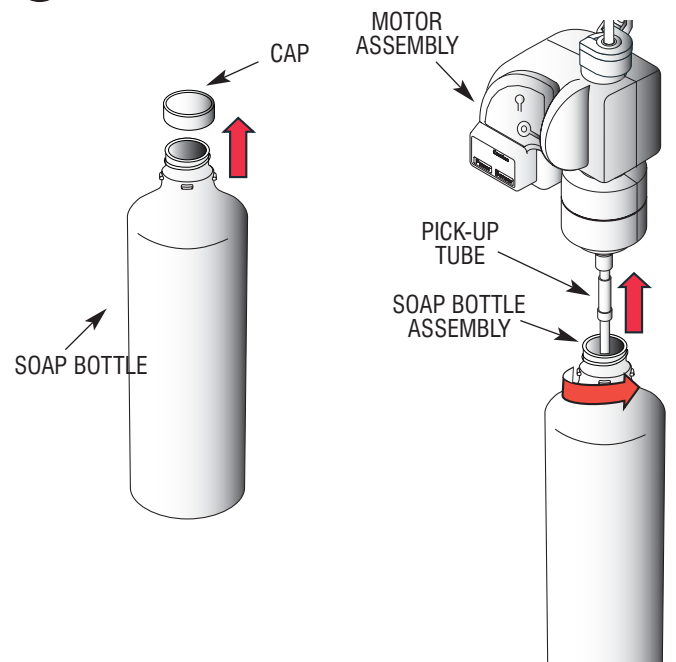

C Slide Soap Assembly up over Straight Tube and fit into the Motor Assembly. Twist Soap Assembly clockwise to lock into place.

3 Mount Battery Compartment

Note: Before mounting, make certain power cord will reach Motor Assembly Connection.

A Using the Battery Compartment as a template, mark the mounting holes on wall. Make certain that the Battery Compartment is level. Secure with the 3 screws (included).

- When mounting onto a concrete wall, drill holes 1/8" diameter and 11/32" or more in depth for wall anchors.
- When mounting onto a wood panel, drill pilot holes 3/32" diameter in advance.

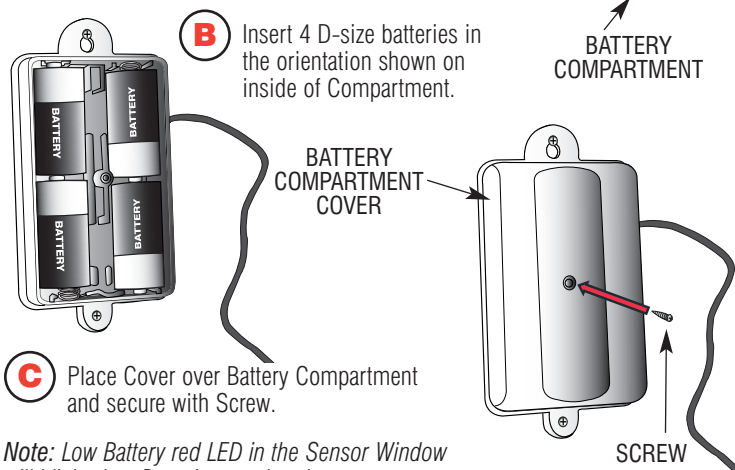

Note: Low Battery red LED in the Sensor Window will blink when Batteries need replacement

4 Attach Tubes to Motor Assembly

A Insert male end of Extension Tube into Motor Assembly and secure with Clip.

B Attach Pick-up Tube into bottom of Motor Assembly.

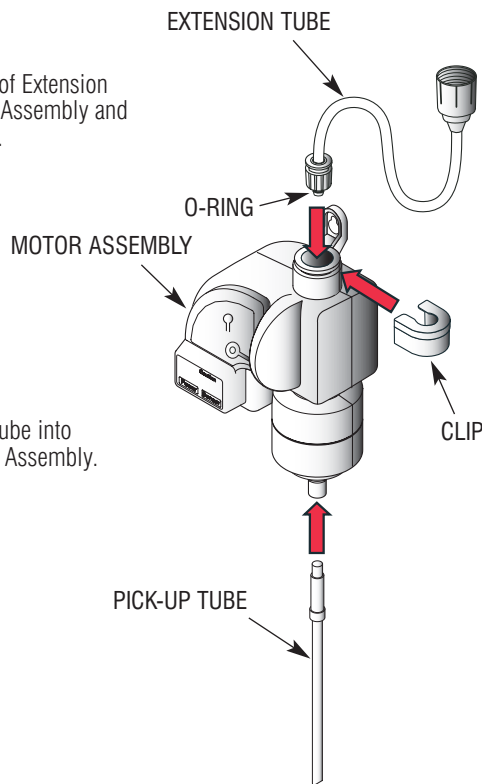

7 Connect Sensor Cable and Power Cable

A Plug Sensor Cable (from Spout) into the marked inlet on the underside of the Motor Assembly.

B Plug Power Cable (from Battery Compartment or optional AC Adapter) into the marked inlet on the underside of the Motor Assembly.

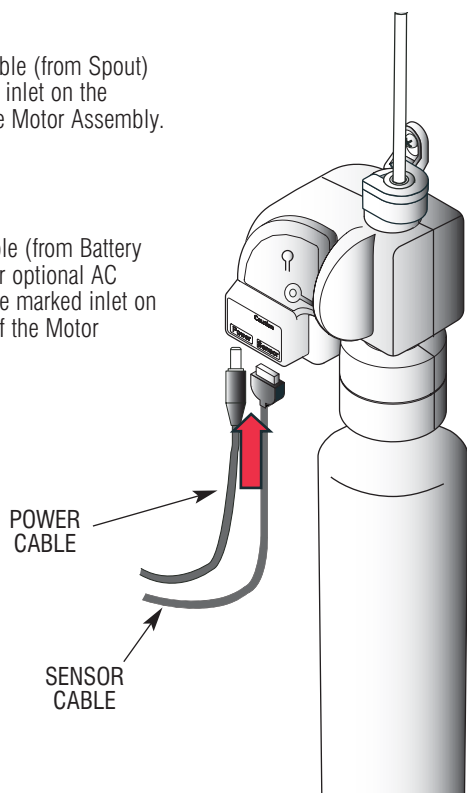

8 Start-up and Operation

A Press Reset Switch on Motor Assembly to begin the priming cycle and purge the air out from the Soap Path. The Reset Switch may need to be pressed again if all the air is not purged out. This procedure must be followed every time the Soap Bottle is replaced.

B Place hand under Spout Nozzle. Sensor will detect hand and dispense one soap application.

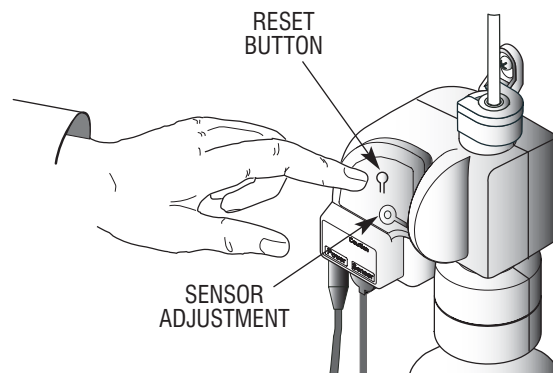

Note: Low Liquid Level yellow LED in the Sensor Window will blink when Soap Bottle needs replacement.

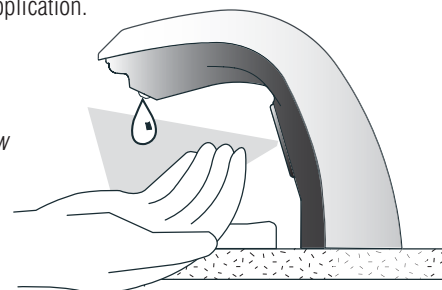

Soap Path Replacement

- A** In the event that the Soap Dispenser is not used for an extended period and the Soap Path becomes clogged, slide the Soap Path out from the Spout.

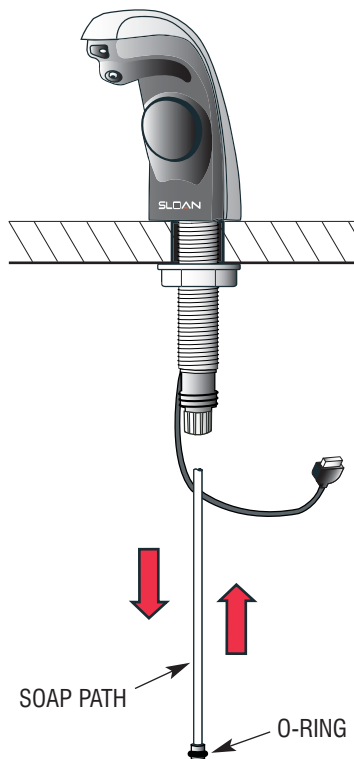

- B** Clean or replace with a new SJS-2 Soap Path.

- C** Slide the Soap Path into the Spout.

CARE AND CLEANING OF CHROME AND SPECIAL FINISHES

DO NOT use abrasive or chemical cleaners (including chlorine bleach) to clean Soap Dispenser that may dull the luster and attack the chrome or special decorative finishes. Use ONLY mild soap and water, then wipe dry with clean cloth or towel.

While cleaning the bathroom tile, protect the Soap Dispenser from any splattering of cleaner. Acids and cleaning fluids will discolor or remove chrome plating.

TROUBLESHOOTING GUIDE

1. Yellow LED light is flashing.

- Soap level is low. Check level and change as needed.
- Reset button was not pressed after the refill was installed. Press and release reset button.

2. Red LED light is flashing (battery power only).

- Batteries are low. Replace with four (4) new D-size alkaline batteries.

3. Soap does not dispense.

- Check that power source is plugged in correctly.
- Make sure batteries have been properly installed in the battery compartment.
- Check soap path for clogging. Remove and replace as needed.

4. Soap does not dispense when user “waves” their hands under the spout.

- Hands must be held steady under the spout for soap to be dispensed.

5. Dispenser rotates due to users moving the spout.

- Tighten the existing flange nut on the shank of the spout under the counter.
- Add a second flange nut from Sloan to act as a jam nut in conjunction with the nut already installed.

When assistance is required, please contact Air Delights Technical Support at: 800-440-5556

PARTS LIST

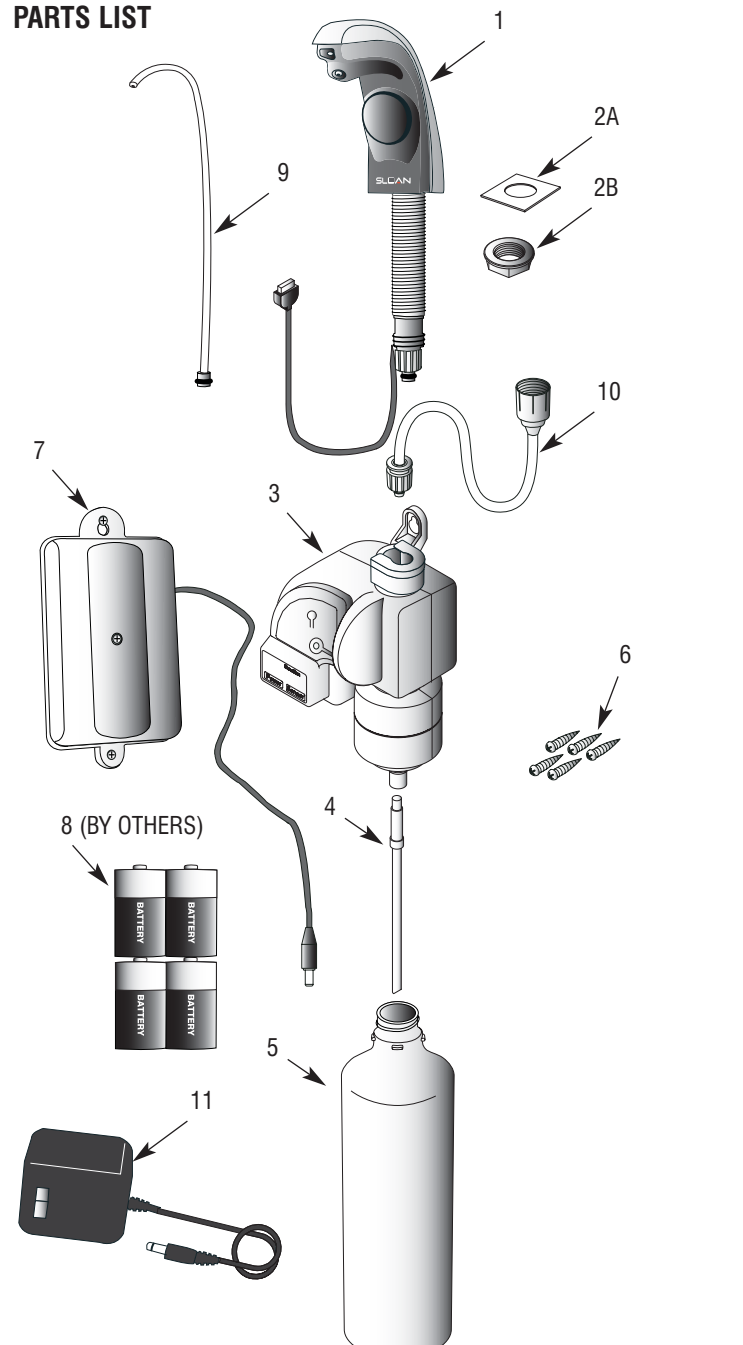

Item No.	Part No.	Description
1	SJS-1-A	Spout Assembly
2A		Rubber Gasket
2B		Flange Nut
3	SJS-5	Motor Assembly
4	SJS-8	Pick-up Tube
5	SJS-1651	Soap Bottle
6		Mounting Screws (5)
7	SJS-4	Battery Compartment
8		D-size Alkaline Batteries (4) (supplied by others)
9	SJS-2	Repair Kit Tube Assembly Soap Path
10	SJS-3	Repair Kit Tube Assembly Extension
11	SJS-7	Optional AC Adapter (sold separately)

The information contained in this document is subject to change without notice.

SLOAN

Air Delights, Inc. • 9974 SW Arctic Dr. • Beaverton, Or. 97005
Phone: 800-440-5556 • Fax: 503-643-8224
www.airdelights.com