

OneShot[®] Plus System

Automatic Foaming Gel

402087
White

402091
Chrome

402089
Black

Exceptionally Luxurious Hand Wash System.

The system delivers a controlled dose of the most luxurious foaming gel wash. Encouraging healthy hand washing which eliminates cross-contamination!

System Features

- SmartSensor™ and patented technology detects user's hand to automatically dispense a controlled dose of foaming gel wash.
- Dose Control allows you to program the dose size.
- Interference Tone – if an object is in field for more than 10 seconds a beep tone will sound.
- Green LED flashes when object is in field.
- Yellow LED light blinks when battery life is low. The light will flash once every second and beeps once every 16 seconds to indicate the batteries need to be replaced. Average battery life 100 refills or 2 plus years.
- Red LED light blinks when refill is low or empty. The light will flash two times every second, and beep twice every eight seconds to indicate the refill needs replacing.
- On/Off Tone Switch allows the user to turn off the tone for low battery/low soap indicator. This can be done once the set up has been completed.
- Installation Set Up – Dispenser must be installed far enough above the counter to prevent interference with the sensor. During the 2-minute set up period, a tone will beep if the counter is too close. Raise the dispenser until the beeping stops and install dispenser at this height.
- On/Off Delay switch provides option of 3 second delay between soap shots.

System Specifications

- up to 1,000 hand washes
- Refill bottle fill volume: 475mL
- Mounts to a wall with screws and anchors or double-sided tape
- Battery requirements: 4 "D" cell alkaline batteries
- Two plus years battery life
- Dispensers: #402087, 402091, 402089

Case Pack: 6 Case Weight: 11 lbs. Case Cube: 1.19



Case Pack: 6
Case Weight: 11 lbs.
Case Cube: 1.19

- Soap Refills:
#402075 - Moisturizing Hand Wash
Up to 1,000 hand washes per refill bottle
Case Pack: 4 Case Weight: 4.5 lbs. Case Cube: .184

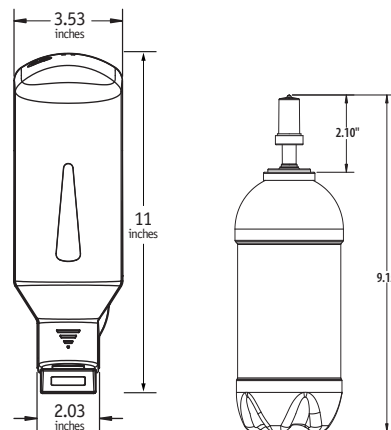

technical concepts
Innovative Hygiene Solutions

Air Delights, Inc.

9974 SW Arctic Dr. , Beaverton, Or. 97005
Phone: 1-800-440-5556 Fax: 503-643-8224
www.airdelights.com