

# SLOAN® FLUSHOMETERS

## Maintenance Guide

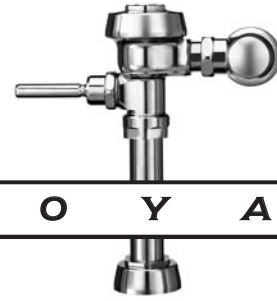

### The Dual Filtered Diaphragm™

Sloan's *Dual Filtered Diaphragm* helps prevent valve "run on" and has been an exclusive feature of the Royal Flushometer since January 1998. Sediment, present in most water supplies, may clog the metering bypass hole in traditional Flushometer valves and cause continuous operation or "run on." The dual patented filter rings on the *Dual Filtered Diaphragm* prevent sediment from reaching the bypass. This results in clog-free operation, eases valve maintenance, and reduces water usage. The *Dual Filtered Diaphragm* is factory assembled to assure an accurate flush delivery.

The Dual Filtered Diaphragm is available as a single drop-in kit (Diaphragm Assembly *only*) or as one of the exclusive components in the Royal Performance Kit. The Dual Filtered Diaphragm can be used in Royal, Regal, and similar diaphragm-style valve bodies. For use in Sloan valve bodies with a bell-shaped cover (manufactured before 1964), replace the bottom filter ring in these kits with a blue A-108 filter ring (not shown; order **5301283** separately in a package of 6).

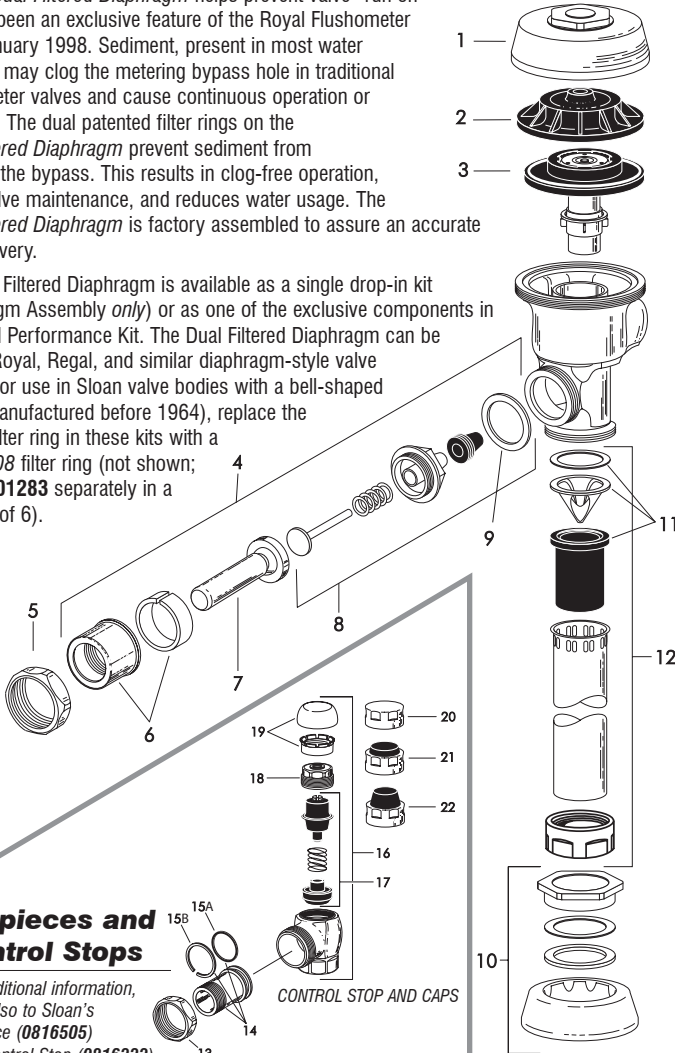

### Tailpieces and Control Stops

For additional information, refer also to Sloan's Tailpiece (0816505) and Control Stop (0816333) Maintenance Guides.

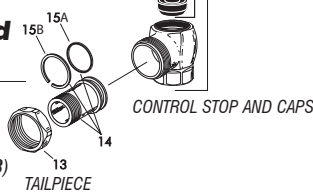

### Parts List — Royal Flushometer Valve

Item	Code No.	Part No.	Description
1	0301172	A-72	CP Cover
2	0301168	A-71	Inside Cover
3	see below	—	<b>Dual Filtered Diaphragm Assembly</b> (refer to table and diagram below)
4	0302390	B-73-A	CP ADA-Compliant Triple Seal Handle Assembly
5	0301082	A-6	CP Handle Coupling
6	0302109	B-7-A	CP Socket Assembly
7	0302389	B-74-A	CP ADA-Compliant Handle
8	3302306	B-51-A	Triple Seal Handle Repair Kit
9	5301139	A-31	Handle Gasket (package of 48)
10	0306125	F-5-A	3/4" (19 mm) CP Spud Coupling Assembly
	0306140	F-5-A	1-1/4" (32 mm) CP Spud Coupling Assembly
	0306146	F-5-A	1-1/2" (38 mm) CP Spud Coupling Assembly
11	3323182	V-651-A	High Back Pressure Vacuum Breaker Repair Kit
12	3393004	V-600-AA	3/4" (19 mm) x 9" (228 mm) CP Vacuum Breaker
	3393006	V-600-AA	1-1/4" (32 mm) x 9" (228 mm) CP Vacuum Breaker
	3393007	V-600-AA	1-1/2" (38 mm) x 9" (228 mm) CP Vacuum Breaker
13	0308676	H-550	CP Stop Coupling
14	0308801	H-551-A	CP Adjustable Tailpiece (2-1/16"/52 mm long)
15A	5308696	H-553	O-Ring (package of 24)
15B	5308381	H-552	Locking Ring (package of 12)
16	3308386	H-700-A	1" (25 mm) CP Bak-Chek® Screwdriver Stop
	3308384	H-700-A	3/4" (19 mm) CP Bak-Chek® Screwdriver Stop
17	3308853	H-541-A	Control Stop Repair Kit †
	3308856	H-543-A	Control Stop Repair Kit ‡
18	0308612	H-622	CP Bonnet †
	0308843	H-577	CP Bonnet ‡
19	3308772	H-1010-A	Vandal Resistant Control Stop Cap Assembly †
	3308790	H-1009-A	Vandal Resistant Control Stop Cap Assembly ‡
20	0308840	H-573	Control Stop Cap CP †
	0308848	H-582	Control Stop Cap CP ‡
21	3308866	H-574	Control Stop Cap with Bumper † (-YO Variation)
22	3308867	H-576	Control Stop Cap with Extended Bumper † (-YG Variation)

† Use with H-700-A (1"/25 mm and 3/4"/19 mm) and H-600-A (1"/25 mm) Bak-Chek® Screwdriver Control Stops.

‡ Use with H-600-A (3/4"/19 mm) Bak-Chek® Screwdriver Control Stops.

Sloan products are also available in Polished Brass, Lustre Gold, and Satin finishes — contact our Customer Service staff for code numbers. If you have any questions about installation, maintenance, or troubleshooting issues, call our Installation Engineering staff at 1-888-SLOAN-14.

**NOTE:** Each item is identified by a Part Number and a Code Number. Expedite processing by using our Code Number. Parts shown service all Sloan diaphragm-type Flushometers manufactured after 1964, including Low Consumption (LC) models.

### ITEM 3: Dual Filtered Diaphragm™ Assembly ••• Available in DIAPHRAGM ONLY and ROYAL Performance™ Kits

**ROYAL Performance™ KIT** includes Dual Filtered Diaphragm Assembly (Item 3), Handle Repair Kit with Triple Seal Packing (Item 8), High Back Pressure Vacuum Breaker Repair Kit (Item 11), and one Tailpiece O-Ring (Item 15). **DIAPHRAGM ONLY KIT** contains "drop-in" Dual Filtered Diaphragm Assembly (Item 3) ONLY.

Performance KIT	Code No.	Kit No.	DIAPHRAGM ONLY KIT	Code No.	Kit No.	Flush Volume	Use With	Relief Valve §	Refill Head ■	Flow Ring
A	3301070	A-1101-A	3301502	A-1041-A	1.6 gpf (6.0 Lpf)	Low Consumption Water Closets	Green	Gray	Smooth	
B	3301071	A-1102-A	3301501	A-1038-A	3.5 gpf (13.2 Lpf)	Water Saver Water Closets	White	Gray	Smooth	
C	3301072	A-1103-A	3301505	A-1044-A	2.4 gpf (9.0 Lpf)	9 Liter European Water Closets	Blue	Gray	Smooth	
D	3301073	A-1106-A	3301504	A-1043-A	0.5 gpf (1.9 Lpf)	Wash Down Urinals	Green	Black	Smooth & Slotted	
E	3301074	A-1107-A	3301503	A-1042-A	1.0 gpf (3.8 Lpf)	Low Consumption Urinals	Green	Black	Slotted	
F	3301075	A-1108-A	3301500	A-1037-A	1.5 gpf (5.7 Lpf)	Water Saver Urinals	Black	Black	Smooth	

§ Consult Sloan Valve Company for availability of replacement plastic Relief Valves (Green, Black, Blue, and White) and brass Relief Valves.

**NOTE:** For older water closets that require 4.5 gpf (17.0 Lpf), choose kits shown on line B, but remove the Flow Ring before use. For blowout-style urinals that require 3.5 gpf (3.2 Lpf), choose kits shown on line B. For service sinks that require 6.5 gpf (24.6 Lpf), order A-36-A diaphragm repair kit (3301036; not shown above) and remove the Flow Ring before use. Regulations for Low Consumption fixtures prohibit the use of higher flush volumes.

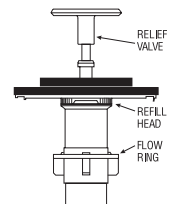

The colors of the Relief Valve and the Refill Head plus the shape of Flow Ring identify the Flush Volume of a DUAL FILTERED DIAPHRAGM ASSEMBLY.

■ Closet Refill Heads (Gray) have larger slots than Urinal Refill Heads (Black).

**NOTE:** In January 1998, the Royal Diaphragm design was upgraded to a preassembled unit with two (2) plastic filtering rings attached to the rubber diaphragm (one on top and one on bottom). If the Flushometer you are servicing has our older, segmented diaphragm with brass bypass hole, refer to our Regal Maintenance Guide (0816185) for additional troubleshooting information.

## Troubleshooting Guide

**ATTENTION INSTALLERS:** With the exception of the Control Stop inlet, DO NOT USE pipe sealant or plumbing grease on any valve component or coupling! To protect the chrome or special finish of Sloan Flushometers, DO NOT USE toothed tools to install or service these valves. Use our Sloan A-50 "Super-Wrench"<sup>™</sup> or other smooth-jawed wrench to secure couplings. Regulations for Low Consumption fixtures (1.6 gpf/6.0 Lpf closets and 1.0 gpf/3.8 Lpf urinals) prohibit use of higher flush volumes.

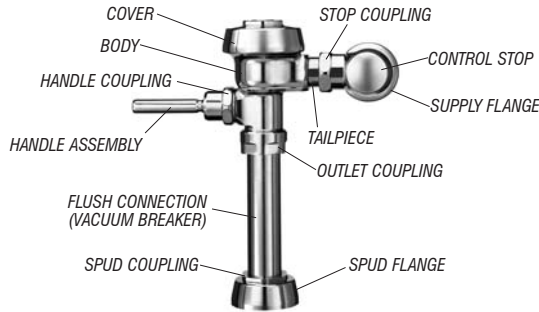

- 1. PROBLEM: Flushometer does not function (no flush).**  
**CAUSE:** Control Stop or main supply valve is closed.  
**SOLUTION:** Open Control Stop or main supply valve.  
**CAUSE:** Handle Assembly is damaged.  
**SOLUTION:** Replace B-73-A Handle or repair with B-51-A Handle Repair Kit.  
**CAUSE:** Relief Valve is damaged.  
**SOLUTION:** Replace Relief Valve.
- 2. PROBLEM: Handle leaks.**  
**CAUSE:** Handle Seal or Handle Assembly is damaged.  
**SOLUTION:** Replace B-73-A Handle or repair with B-51-A Handle Repair Kit.
- 3. PROBLEM: Water splashes from fixture.**  
**CAUSE:** Control Stop is open wider than necessary.  
**SOLUTION:** Adjust Control Stop for desired delivery of water volume.  
**CAUSE:** Water Saver/Conventional Diaphragm Assembly is installed on Low Consumption fixture or Closet Diaphragm Assembly is installed on Urinal fixture.  
**SOLUTION:** Determine the required flush volume (see label on valve or markings on fixture). Replace Diaphragm Assembly or Relief Valve for appropriate flush volume of fixture.
- 4. PROBLEM: Volume of water is insufficient to adequately siphon fixture.**  
**CAUSE:** Control Stop is not open wide enough.  
**SOLUTION:** Adjust Control Stop for desired delivery of water volume.  
**CAUSE:** Diaphragm Assembly is damaged.  
**SOLUTION:** Replace Diaphragm Assembly.  
**CAUSE:** Low Consumption Diaphragm Assembly is installed on Water Saver/Conventional fixture or Urinal Diaphragm Assembly is installed on Closet fixture.  
**SOLUTION:** Determine the required flush volume (see label on valve or markings on fixture). Replace Diaphragm Assembly or Relief Valve for appropriate flush volume of fixture.  
**CAUSE:** Inadequate water volume or pressure is available from supply.  
**SOLUTION:** Increase flow rate or pressure to the valve. If gauges are not available to measure supply pressure/volume, remove Relief Valve from Diaphragm Assembly and open the Control Stop.  
**If the fixture siphons:** Additional water volume is required. Install higher flushing volume Relief Valve or Diaphragm Assembly or cut Flow Ring from Guide.  
**If the fixture DOES NOT siphon (or a Low Consumption flush is required):** Additional steps must be taken to increase the water pressure and/or volume at the water supply. Contact fixture manufacturer for minimum supply requirements of fixture.

- 5. PROBLEM: Flushometer valve closes immediately (short flush).**  
**CAUSE:** Worn or damaged Diaphragm Assembly.  
**SOLUTION:** Replace Diaphragm Assembly.  
**CAUSE:** Handle Assembly is damaged.  
**SOLUTION:** Replace B-73-A Handle or repair with B-51-A Handle Repair Kit.  
**CAUSE:** Low Consumption Diaphragm Assembly is installed on Water Saver/Conventional fixture or Urinal Diaphragm Assembly is installed on Closet fixture.  
**SOLUTION:** Determine the required flush volume (see label on valve or markings on fixture). Replace Diaphragm Assembly or Relief Valve for appropriate flush volume of fixture.
- 6. PROBLEM: Length of flush is too long (long flush) or fails to shut off.**  
**CAUSE:** Bypass hole (upper filter ring) of Diaphragm Assembly is dirty.  
**SOLUTION:** Remove the Diaphragm Assembly. Disassemble the filter rings from the Diaphragm, wash under running water, and reassemble. Replace as necessary.  
**CAUSE:** Relief Valve or Diaphragm Assembly is damaged.  
**SOLUTION:** Replace Relief Valve or Diaphragm Assembly.  
**CAUSE:** Water Saver/Conventional Diaphragm Assembly is installed on Low Consumption fixture or Closet Diaphragm Assembly is installed on Urinal fixture.  
**SOLUTION:** Determine the required flush volume (see label on valve or markings on fixture). Replace Diaphragm Assembly or Relief Valve for appropriate flush volume of fixture.  
**CAUSE:** Inside Cover is damaged.  
**SOLUTION:** Install new A-71 Inside Cover.  
**CAUSE:** Line water pressure dropped and is insufficient to close valve.  
**SOLUTION:** Close the Control Stop until pressure is restored.  
**CAUSE:** Relief Valve is not seated properly.  
**SOLUTION:** Disassemble Diaphragm components (Relief Valve, Filter Rings, and Diaphragm unit), wash under running water, and reassemble. Replace as necessary.
- 7. PROBLEM: Chattering noise is heard during flush.**  
**CAUSE:** Inside Cover is damaged.  
**SOLUTION:** Install new A-71 Inside Cover.  
**CAUSE:** Relief Valve or Diaphragm Assembly is damaged.  
**SOLUTION:** Replace Relief Valve or Diaphragm Assembly.

### Care and Cleaning Instructions

DO NOT USE abrasive or chemical cleaners to clean Flushometers that may dull the luster and attack the chrome or decorative finish. Use ONLY soap and water, then wipe dry with a clean towel or cloth. When cleaning the bathroom tile, protect the Flushometer from any splattering of cleaner. Acids and cleaning fluids can discolor or remove chrome plating.

.....  
 If further assistance is required, please contact Sloan Valve Company Installation Engineering Department at  
**1-800-440-5556.**

### LIMITED WARRANTY

Sloan Valve Company warrants its Flushometer Products to be made of first class materials, free from defects of material or workmanship under normal use and to perform the service for which they are intended in a thoroughly reliable and efficient manner when properly installed and serviced for a period of 3 years (1 year for special finishes) from date of purchase. During this period, Sloan Valve Company will, at its option, repair or replace any part or parts which prove to be thus defective if returned to Sloan Valve Company, at customer's cost, and this shall be the sole remedy available under this warranty. No claims will be allowed for labor, transportation or other incidental costs. This warranty extends only to those persons or organizations who purchase Sloan Valve Company's products directly from Sloan Valve Company for purpose of resale.

**THERE ARE NO WARRANTIES WHICH EXTEND BEYOND THE DESCRIPTION ON THE FACE HEREOF. IN NO EVENT IS SLOAN VALVE COMPANY RESPONSIBLE FOR ANY CONSEQUENTIAL DAMAGES OF ANY MEASURE WHATSOEVER.**

The information contained in this document is subject to change without notice.

**AIR DELIGHTS, INC. - 9974 SW ARCTIC DR. - BEAVERTON, OR. 97005**

Phone: 1-800-440-5556 • Fax: 1-503-643-8224 • <http://www.airdelights.com>